

# Category 6 SL Series 110Connect Modular Jacks

1375055-X, 1375187-X, 1375188-1, 1479552-1

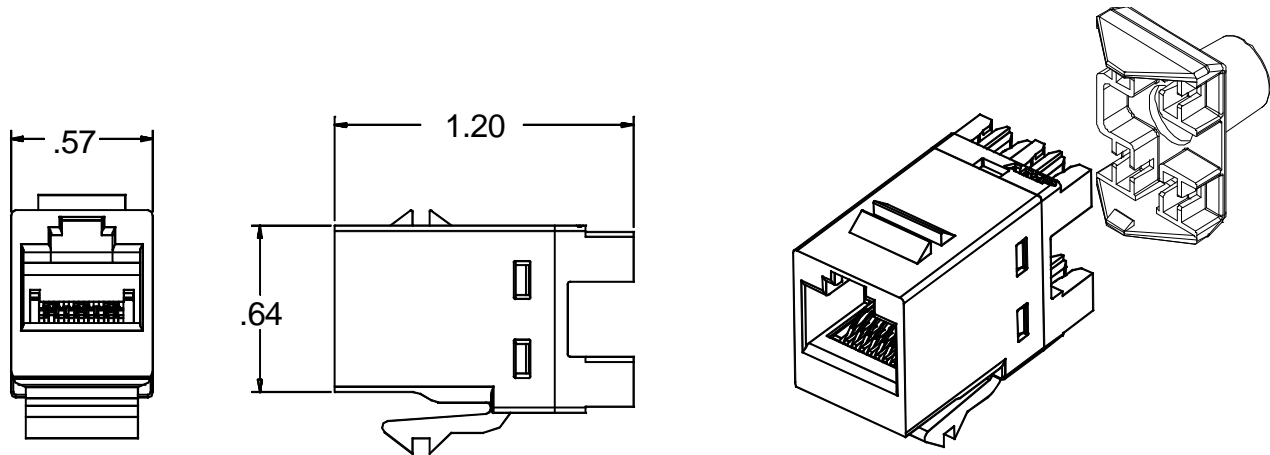

## Description

AMP NETCONNECT Category 6 SL Series 110Connect Modular Jacks exceed TIA/EIA-568-B.2-1 and ISO/IEC 11801 requirements for Category 6/Class E component performance. The AMP NETCONNECT Category 6 System complies with all of the performance requirements for current and proposed applications such as Gigabit Ethernet (1000BASE-TX), 10 and 100BASE-TX, token ring, 155 Mbps ATM, 100 Mbps TP-PMD, ISDN, analog and digital video, and analog and digital voice (VoIP).

AMP NETCONNECT Category 6 SL Series 110Connect Modular Jacks have a slim profile and are compatible with SL Series and 110Connect faceplates. Universal wiring labels permit termination to either T568A or T568B wiring patterns. The modular jacks are available with and without integral dust covers and in a shielded version as well. Cables may be dressed at either 180°(rear) or 90° (either side) for added flexibility; shielded Modular Jacks have special shields to support this option. Patented bend-limiting strain relief may also be used to reduce stress on cable at point of termination and is included with each unshielded Modular Jack. SL Series 110Connect Modular Jacks are available in almond, black, white, gray, orange, blue, red, yellow, green, violet, and electrical ivory (see part number table for color samples).

## Specification (text in brackets [ ] requires a choice)

Modular jacks shall be unkeyed, [unshielded or shielded], 4-pair, RJ-45, and shall fit in a .790" X .582" opening. Modular jacks shall terminate using 110-style pc board connectors, color-coded for both T568A and T568B wiring. Each modular jack shall be wired to [T568A or T568B]. The 110-style insulation displacement connectors shall be capable of terminating 22-24 AWG solid or 24 AWG stranded conductors. The insulation displacement contacts shall be paired, with additional space between pairs, to improve crosstalk performance. Modular jacks shall utilize a secondary PC board, separate from the signal path, for crosstalk compensation. Each modular jack shall meet the [TIA/EIA-568-B.2-1, Category 6 or ISO/IEC 11801 Class E] performance standards and the requirements listed in the following table.

[include Performance Characteristics table from page 2]

Modular Jacks shall be compatible with AMP NETCONNECT SL Series Termination Tool part number 1725150-1. Each modular jack shall be provided with a bend-limiting strain relief. The strain relief shall provide cylindrical support to limit the bend radius at the point of termination. [Each jack shall incorporate an integral, hinged dust cover]. Modular jacks shall be UL Listed under file number E81956. Modular jacks shall be AMP NETCONNECT part number [1375055-X, 1375187-X, 1375188-1 or 1479552-1 (X denotes color, see part number table)] and be [almond, black, white, gray, orange, blue, red, yellow, green, violet, or electrical ivory] in color.

## Part Numbers

Description	Wiring Pattern	Part Numbers	
Category 6 SL Series 110Connect Modular Jacks	T568A/T568B	Unshielded	1375055-X
		With Dust Cover	1375187-X
	Shielded	180°(Rear) Entry Shield	1375188-1*
		90°(Side) Entry Shield	1479552-1*

X denotes color: -1 = Almond, -2 = Black, -3 = White, -4 = Gray, -5 = Orange, -6 = Blue, -7 = Red, -8 = Yellow, -9 = Green, 1- -0 = Violet, 1- -1 = Electrical Ivory

\*NOTE: Shielded Modular Jacks are available in black only and do not accept strain relief.

Title

Part Numbers

---

# Category 6 SL Series 110Connect Modular Jacks

1375055-X, 1375187-X, 1375188-1, 1479552-1

## Worst-Case Performance Characteristics (exceed EIA/TIA and ISO/IEC Category 6/Class E requirements)

Frequency MHz	Insertion Loss (dB)		Return Loss (dB)		NEXT (dB)		FEXT (dB)	
	Category 6 Standard	Max	Category 6 Standard	Min	Category 6 Standard	Min	Category 6 Standard	Min
1	0.10	0.02	30	52.4	75.0	84.8	75.0	83.7
4	0.10	0.02	30	53.7	75.0	80.3	71.1	74.8
8	0.10	0.02	30	55.3	75.0	77.4	65.0	69.4
10	0.10	0.03	30	56.1	74.0	76.4	63.1	67.5
16	0.10	0.03	30	57.6	69.9	72.0	59.0	62.9
20	0.10	0.04	30	59.3	68.0	71.9	57.1	61.7
25	0.10	0.04	30	59.4	66.0	69.1	55.1	59.8
31.25	0.11	0.05	30	56.8	64.1	67.7	53.2	58.2
62.5	0.16	0.06	28	42.3	58.1	61.5	47.2	52.6
100	0.20	0.06	24	33.2	54.0	57.7	43.1	48.7
200	0.28	0.06	18	21.2	48.0	52.5	37.1	42.2
250	0.32	0.10	16	17.4	46.0	47.9	35.1	40.1

## Technical Details

### Materials

Modular Jack Housing	– Polyphenylene oxide, 94V-0 rated
110 Connecting Blocks	– Polycarbonate, 94V-0 rated
Contacts	– Beryllium copper, plated with 1.27µm [50µin] thick gold in localized area and 3.81µm [150µin] minimum thick matte tin in solder area over 1.27 µm [50 µin] minimum thick nickel underplate
Insulation Displacement Contacts	– Phosphorous bronze, plated with 3.81µm [150µin] minimum thick matte tin-lead over 1.27µm [50µin] minimum thick nickel underplate
Integral Dust Cover	– Polycarbonate
Shield	– Copper zinc alloy 260, pre-plated with bright nickel
Strain Relief	– Polycarbonate

### Electrical Characteristics

Modular Jack	– 750 mating cycles	Voltage	– 150VAC max.
110 Contacts	– 200 terminations	Operating Temperature	– -40° – 70°C (-40° – 158°F)
Pull Force	– 20lbs (89N)		

### Packaging

Modular Jack	– 1 per bag, 25 per carton
Strain Relief	– 1 per bag

### Approvals

UL Listed, file number E81956, CSA

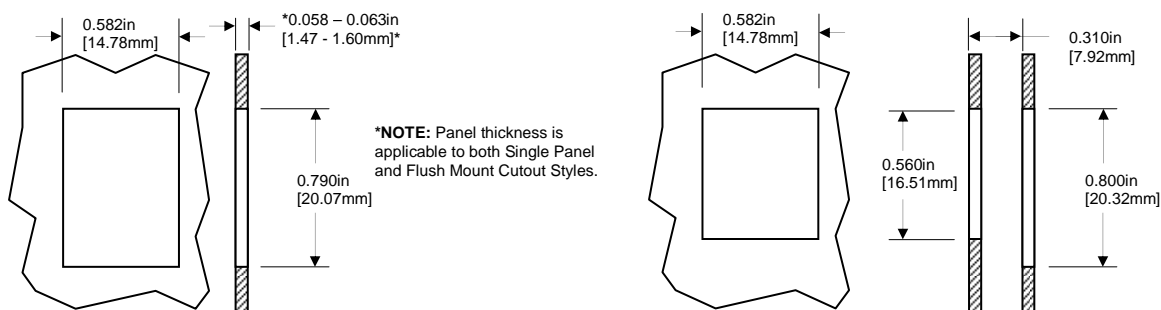

Single Panel Cutout

Suggested Flush Mount Panel Application Cutout

In the U.S.A 1-800-553-0938  
 Canada 905-475-6222  
 Mexico 525-729-0400  
 South and Central Americas 54-11-4733-2200

web: <http://www.ampnetconnect.com/>  
 e-mail: [networking.help@tycoelectronics.com](mailto:networking.help@tycoelectronics.com)

©Copyright 2008 by Tyco Electronics Corporation. All Rights Reserved. AMP, AMP NETCONNECT, NETCONNECT, and Tyco are trademarks.  
 Specifications subject to change without notice.

Last Updated - 4/16/2008

