



**Obsolete**

**CA4  
CT4  
CS4**

**OBSOLETE**

Please contact your local representative regarding pricing or other information in this document.

**sprecher+  
schuh**

# Series CA4 Contactors and CAT4 Starters

0  
Contactors  
CA4

An ingenious miniature contactor and starter system

Obsolete  
May 2008  
Convert to CA8

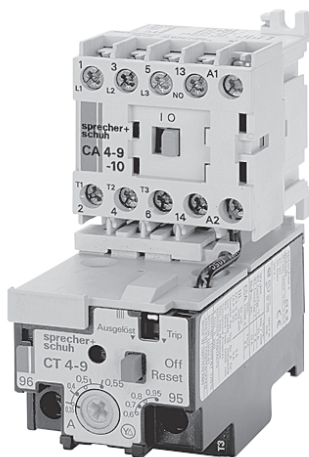

CAT4 starters feature the new CT4 thermal overload.

Sprecher + Schuh's CA4 Series of miniature contactors and starters provide an extremely compact and reliable method of controlling motors of 7.5 HP or less (@460V). The CA4 is an economical choice for applications where space is limited or where a minimal enclosure is desired.

## Small but rugged

Even though their contacts and coils are not replaceable, Sprecher + Schuh has subjected this series of contactors to monitored endurance tests that demonstrate their ruggedness. At full load, under 3-phase power, the contacts in the CA4 have an electrical life of 700,000 operations, while the AC magnet system has a mechanical life of 10,000,000 operations.

## The CAT4 Starter – Efficient and reliable

This miniature starter features the new CT4 Thermal Overload Relay. A complex current limiting calibration procedure performed after each unit is what ensures the consistent high quality of Sprecher + Schuh's thermal overload relay. Today's, Class 10 T-frame design like the CT Series has been recognized by many motor manufacturers as the ideal type to assure optimum motor protection due to less use of copper and iron. For a complete description of Sprecher + Schuh CT4 Overload Relays, see Section B in this catalog.

## Accessories require no additional panel space

The entire CA4 System is logically engineered. Modular accessories like auxiliary contact blocks and timing elements snap-on without increasing the CA4's original width of 45mm. Also, due to its horizontal switching movement, the basic contactor has the same low profile whether an AC or DC operating magnet is used. This permits the use of enclosures with shallow mounting depths. Once the CA4 is installed, all auxiliary contact

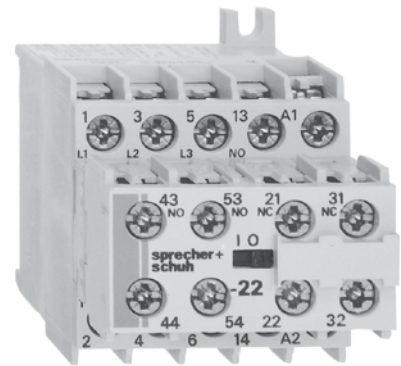

blocks can be snapped-on or removed without changing any existing power wiring. Other accessories include a snap-on RC Link (surge suppressor), mechanical interlocks and space saving adaptors for connecting auxiliary components.

## Effortless installation

Both the CA4 Contactor and the CAT4 Starter are DIN-rail mountable for instant installation and modification. Fittings are also included on the CA4 for base mounting. All terminals are clearly marked and shipped in the open position for installation with either manual or power screwdrivers.

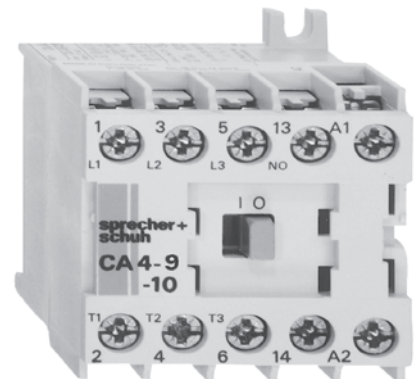

40mm  
(±1 7/16)



9A  
12A

#### Non-Reversing, Three Pole Contactors With AC Coil, Series CA4 (Open type only) ❶

$I_e$ [A]		Ratings for Switching AC Motors (AC2 / AC3 / AC4)									Auxiliary Contacts per Contactor		Open Type	
		kW (50 Hz)			UL/CSA HP (60 Hz)									
		AC-3	AC-1	230V	400V 415V	500V	1 Ø			3 Ø				
115V	230V						200V	230V	460V	575V				
9	20	3	4	4	1/2	1-1/2	2	2	5	5	NO	NC	CA4-9-10-*	Refer to Factory
											0	1	CA4-9-01-*	
12	20	3	5.5	4	1/2	2	3	3	7-1/2	10	1	0	CA4-12-10-*	
											0	1	CA4-12-01-*	



CA4-9-01 contactor

#### Non-Reversing, Three Pole Contactors With DC Coil, Series CA4 (Open type only) ❶❷

$I_e$ [A]		Ratings for Switching AC Motors (AC2 / AC3 / AC4)									Auxiliary Contacts per Contactor		Open Type	
		kW (50 Hz)			UL/CSA HP (60 Hz)									
		AC-3	AC-1	230V	400V 415V	500V	1 Ø			3 Ø				
115V	230V						200V	230V	460V	575V				
9	20	3	4	4	1/2	1-1/2	2	2	5	5	NO	NC	CA4-9C-10-*	Refer to Factory
											0	1	CA4-9C-01-*	
12	20	3	5.5	4	1/2	2	3	3	7-1/2	10	1	0	CA4-12C-10-*	
											0	1	CA4-12C-01-*	



CA4-9C-10 contactor

#### A.C. Coil Codes ❶❸

AC Coil Code	Voltage Range	
	50 Hz	60 Hz
12	12V	12V
24	24V	24V
48	48V	48V
120	110V	110V-120V
208	200V-230V	200V-230V
240	220V-230V	230V-240V
380	380V-400V	400V-415V
480	440V	440V-480V
575	~	575V-600V

#### D.C. Coil Codes ❶

DC Coil Code	Voltage
12D	12V
24D	24V
48D	48V
110D	110V
220D	220V

#### Ordering Instructions

● Specify Catalog Number	See Coil Code table on this page for codes
● Replace (*) with Coil Code	

- ❶ CA4 not available without coil. Coils and contacts not replaceable.
- ❷ Select Coil Code from D.C. Coil Code table only.
- ❸ Value only applies to AC-2 and AC-3.
- ❹ The coil codes shown are the most commonly stocked items. Contact your Sprecher + Schuh representative to determine if other voltages, i.e., 12, 208, 480 and 575V are on-hand or can be specially ordered in quantities.

0  
Contactors  
CA4

### Non-Reversing, Four Pole Contactors With AC Coil, Series CA4 (Open type only) ①④

$I_e$ [A]		Ratings for Switching AC Motors (AC2 / AC3 / AC4)									Contact configuration main poles		Open Type	
		kW (50 Hz)			UL/CSA HP (60 Hz)									
		AC-3	AC-1	230V	400V	500V	1 Ø			3 Ø				
							415V		115V	230V	200V	230V	460V	575V
9	20	3	4	4	1/3	1	2	2	1	1	4	0	CA4-9-M40-*	R/F



CA4-9-M40 contactor

### Non-Reversing, Four Pole Contactors With DC Coil, Series CA4 (Open type only) ①②④

$I_e$ [A]		Ratings for Switching AC Motors (AC2 / AC3 / AC4)									Contact configuration main poles		Open Type	
		kW (50 Hz)			UL/CSA HP (60 Hz)									
		AC-3	AC-1	230V	400V	500V	1 Ø			3 Ø				
							415V		115V	230V	200V	230V	460V	575V
9	20	3	4	4	1/3	1	2	2	1	1	4	0	CA4-9C-M40-*	R/F



CA4-9C-M40 contactor

### A.C. Coil Codes ①③

AC Coil Code	Voltage Range	
	50 Hz	60 Hz
12	12V	12V
24	24V	24V
48	48V	48V
120	110V	110V-120V
208	200V-230V	200V-230V
240	220V-230V	230V-240V
380	380V-400V	400V-415V
480	440V	440V-480V
575	~	575V-600V

### D.C. Coil Codes ①

DC Coil Code	Voltage
12D	12V
24D	24V
48D	48V
110D	110V
220D	220V

### Ordering Instructions

● Specify Catalog Number	See Coil Code table on this page for codes
● Replace (*) with Coil Code	

- ① CA4 not available without coil. Coils and contacts not replaceable.
- ② Select Coil Code from D.C. Coil Code table only.
- ③ The coil codes shown are the most commonly stocked items. Contact your Sprecher + Schuh representative to determine if other voltages, i.e., 12, 208, 480 and 575V are on-hand or can be specially ordered in quantities.
- ④ No auxiliary contacts provided in the base of a CA4. Add auxiliaries from pg. A133.

Reversing, Three Pole Contactors With AC Coil, Series CAU4 (Open type only) ❶

I <sub>e</sub> [A]		Ratings for Switching AC Motors (AC2 / AC3 / AC4)									Auxiliary Contacts per Contactor		Open Type		Price
		kW (50 Hz)			UL/CSA HP (60 Hz)										
		AC-3	AC-1	230V	400V 415V	500V	1 Ø			3 Ø					
										115V	230V	200V	230V	460V	575V
9	20	3	4	4	1/2	1-1/2	2	2	5	5	0	1	CAU4-9-02-*-LW	Refer to Factory	
											2	1	CAU4-9-42-*-PW		
12	20	3	5.5	4	1/2	2	3	3	7-1/2	10	0	1	CAU4-12-02-*-LW		
❷			❸								2	1	CAU4-12-42-*-PW		



0  
Contactors  
CA4

**Note:** Reversing CA4 contactors with DC coils will not accept a mechanical interlock and are not available except by special order

**CAU4...LW Includes:**

- Mechanical interlock

**CAU4...PW Includes:**

- Mechanical and electrical interlock ❷
- Reversing power and control wiring (using Wiring Kit Cat.# KCR4)
- Top mount auxiliary contact block (Cat.# CS4-P20 on the -42- models)

OBSOLETE

**A.C. Coil Codes ❶❹**

AC Coil Code	Voltage Range	
	50 Hz	60 Hz
12	12V	12V
24	24V	24V
48	48V	48V
120	110V	110V-120V
208	200V-230V	200V-230V
240	220V-230V	230V-240V
380	380V-400V	400V-415V
480	440V	440V-480V
575	~	575V-600V

**Ordering Instructions**

● Specify Catalog Number	
● Replace (*) with Coil Code	See Coil Code table on this page for codes

- ❶ CA4 not available without coil. Coils and contacts not replaceable.
- ❷ Internal NC contacts on each contactor are used for electrical interlocking.
- ❸ Value only applies to AC-2 and AC-3.
- ❹ The coil codes shown are the most commonly stocked items. Contact your Sprecher + Schuh representative to determine if other voltages, i.e., 12, 208, 480 and 575V are on-hand or can be specially ordered in quantities.

### Non-Reversing, Three Pole Starters With AC Coil, Series CAT4 (Open type only) ①

$I_e$ [A]		Ratings for Switching AC Motors (AC2 / AC3 / AC4)									Auxiliary Contacts per Contactor		Open Type	
		kW (50 Hz)			UL/CSA HP (60 Hz)									
					1 Ø			3 Ø						
AC-3	AC-1	230V	400V 415V	500V	115V	230V	200V	230V	460V	575V	NO	NC	Catalog Number	Price
9	20	3	4	4	1/2	1-1/2	2	2	5	5	1	0	CAT4-9-10-*◆	Refer to Factory
											0	1	CAT4-9-01-*◆	
12	20	3	5.5	4	1/2	2	3	3	7-1/2	10	1	0	CAT4-12-10-*◆	
③			③								0	1	CAT4-12-01-*◆	



CAT4-9... starter with the economical CT4 bimetallic overload relay

### Non-Reversing, Three Pole Starters With DC Coil, Series CAT4 (Open type only) ①②

$I_e$ [A]		Ratings for Switching AC Motors (AC2 / AC3 / AC4)									Auxiliary Contacts per Contactor		Open Type	
		kW (50 Hz)			UL/CSA HP (60 Hz)									
					1 Ø			3 Ø						
AC-3	AC-1	230V	400V 415V	500V	115V	230V	200V	230V	460V	575V	NO	NC	Catalog Number	Price
9	20	3	4	4	1/2	1-1/2	2	2	5	5	1	0	CAT4-9C-10-*◆	Refer to Factory
											0	1	CAT4-9C-01-*◆	
12	20	3	5.5	4	1/2	2	3	3	7-1/2	10	1	0	CAT4-12C-10-*◆	
③			③								0	1	CAT4-12C-01-*◆	

**NOTE:** CAT4 starters are priced to include Sprecher + Schuh's CT4 bimetallic overload relay. See page A136 for selection.

### CAT4 Starters with CT4 Thermal Overload Relay

For us with contactor....	Amp Range	Overload Relay Code (▲)	Catalog Number (of Overload Relay used)
<b>1 or 3-Phase, Auto/Manual, Class 10</b>			
CA4-9	0.1...0.32	T4A	CT4-0.15
	0.15...0.23	T4B	CT4-0.23
	0.23...0.35	T4C	CT4-0.35
	0.35...0.55	T4D	CT4-0.55
	0.55...0.80	T4E	CT4-0.80
	0.80...1.2	T4F	CT4-1.2
	1.2...1.8	T4G	CT4-1.8
	1.8...2.7	T4H	CT4-2.7
	2.7...4.0	T4J	CT4-4.0
	4.0...6.0	T4K	CT4-6.0
CA4-12	6.0...7.7	T4L	CT4-7.7
	7.5...9.0	T4M	CT4-9.0
	8.8...10.5	T4N	CT4-10.5
	10.4...12.5	T4P	CT4-12

### A.C. Coil Codes ①④

AC Coil Code	Voltage Range	
	50 Hz	60 Hz
12	12V	12V
24	24V	24V
48	48V	48V
120	110V	110V-120V
208	200V-230V	200V-230V
240	220V-230V	230V-240V
380	380V-400V	400V-415V
480	440V	440V-480V
575	~	575V-600V

### D.C. Coil Codes ①

DC Coil Code	Voltage
12D	12V
24D	24V
48D	48V
110D	110V
220D	220V

### Ordering Instructions

● Specify Catalog Number	
● Replace (*) with Coil Code	Coil Codes on this page O/L Relay Code above
● Replace (◆) with O/L Relay Code	

- ① CA4 not available without coil. Coils and contacts not replaceable.
- ② Select Coil Code from D.C. Coil Code table only.
- ③ Value only applies to AC-2 and AC-3.
- ④ The coil codes shown are the most commonly stocked items. Contact your Sprecher + Schuh representative to determine if other voltages, i.e., 12, 208, 480 and 575V are on-hand or can be specially ordered in quantities.

Reversing, Three Pole Starters With AC Coil, Series CAUT4 (Open type only) ①②③

I <sub>e</sub> [A]		Ratings for Switching AC Motors (AC2 / AC3 / AC4)									Auxiliary Contacts per Contactor		Open Type	
		kW (50 Hz)			UL/CSA HP (60 Hz)									
		AC-3	AC-1	230V	400V	500V	1 Ø			3 Ø				
							415V		115V	230V	200V	230V	460V	575V
9	20	3	4	4	1/2	1-1/2	2	2	5	5	0	1	CAUT4-9-02-*◆-LW	Refer to Factory
											2	1	CAUT4-9-42-*◆-PW	
12	20	3	5.5	4	1/2	2	3	3	7-1/2	10	0	1	CAUT4-12-02-*◆-LW	
④			④								2	1	CAUT4-12-42-*◆-PW	



0  
Contactors  
CA4

**NOTE:** Reversing CA4 starters with DC coils will not accept a mechanical interlock and are not available.

**CAUT4...LW Includes:**

- Mechanical interlock
- Your choice of CEP7 First Generation solid state or CT4 bimetallic overload relay. Select code from page A136. See features and functions of both relays in Section B of this catalog

**CAUT4...PW Includes:**

- Mechanical and electrical interlock ②
- Reversing power and control wiring (using Wiring Kit Cat.# KCR4)
- Top mount auxiliary contact block (Cat.# CS4-P20 on the -42- models)
- Select *only* CEP7 First Generation solid state Overload Relay Code from page A136 ③

A.C. Coil Codes ①⑤













AC Coil Code	Voltage Range	
	50 Hz	60 Hz
12	12V	12V
24	24V	24V
48	48V	48V
120	110V	110V-120V
208	200V-230V	200V-230V
240	220V-230V	230V-240V
380	380V-400V	400V-415V
480	440V	440V-480V
575	~	575V-600V

Ordering Instructions



● Specify Catalog Number	
● Replace (*) with Coil Code	Coil Codes on this page O/L Relay Code on pg. 6
● Replace (◆) with O/L Relay Code	

- ① CA4 not available without coil. Coils and contacts not replaceable.
- ② NC contacts on each contactor are used for electrical interlocking.
- ③ If selecting CAUT4-9-42-\*◆-PW reversing starter, only use Overload Relay Code for a CEP7 solid state overload relay. CT4 Thermal Overload Relay is not compatible with power wiring kit.
- ④ Value only applies to AC-2 and AC-3.
- ⑤ The coil codes shown are the most commonly stocked items. Contact your Sprecher + Schuh representative to determine if other voltages, i.e., 12, 208, 480 and 575V are on-hand or can be specially ordered in quantities.



### Auxiliary Contact Blocks (2 & 4 Pole)

Auxiliary Contact Blocks	NO	NC	Contact Arrangement	Catalog Number
	0	2		CA4-P02
	0	2		CS4-P02
<i>Contact blocks snap on without tools</i>	1	1		CA4-P11
	1	1		CS4-P11
	2	0		CS4-P20
<i>2-pole auxiliary contact block (typical)</i>	0	4		CS4-P04
	2	2		CA4-P22
	2	2		CS4-P22
<i>4-pole auxiliary contact block (typical)</i>	4	0		CS4-P40

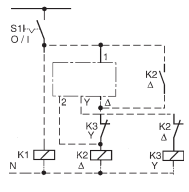
### Control Modules

Module	Description	For use with...	Connection Diagrams	Function	Catalog Number
	<b>Electronic Timing Module – ON-Delay</b> The contactor is energized at the end of the delay time.	CA4 all		110...250V 50/60Hz 0.1...3 sec. 1...30 sec	<b>CRZE4-3S</b> <b>CRZE4-30S</b>
	<b>Electronic Timing Module – Wye-Delta Transition Timer</b> After the set time has elapsed, the contactor K3 (Y) is de-energized, and then after 90ms nominal ( $\pm 30$ ms), the contactor K2 (D) is energized.	CA4 all		48V 50/60Hz 1...30sec. 110...120V 50/60Hz 1...30 sec. 220...250V 50/60Hz 1...30 sec..	<b>CRZY4-30S-48V</b> <b>CRZY4-30S-120V</b> <b>CRZY4-30S-250V</b>



**Miscellaneous Accessories**

Accessory	Description	Catalog Number
	<p><b>Surge Suppressor CRC4</b> - Limits voltage spikes when switching off coil. Attaches to all CA4 contactors, CT4 overload relays and auxiliary contact blocks. Coil itself provides sufficient limitation at voltages over 240V.</p> <p>RC Link (Type CRC4...) 24-48VAC 110-280VAC 380-480VAC</p> <p>Diode Link (Type CRD4...) ❶</p>	<p>25.950.121-01 25.950.121-02 25.950.121-03 25.950.123-02</p>
	<p>Varistor Link (Type CRV4...) 12-55VAC/12-77VDC 56-136VAC/78-180VDC 137-277VAC/181-350VDC</p>	<p>25.950.122-01 25.950.122-02 25.950.122-03</p>
	<p><b>Mechanical Interlock Kit</b> - for CA4 contactors with AC coil.</p>	<p>25.951.301-01</p>
	<p><b>Wiring Kit</b> - ❷ For connecting line, load and control wiring of a CAU4 reversing contactor. May not be used with CT4 Thermal Overload relay. May be used with CEP7 Solid State O/L if CEP7 adaptor bracket is removed.</p>	<p>KCR4</p>
	<p><b>Adaptor</b> - For mounting CRZE4 and CRZY4 Electronic Timers to DIN-rails.</p>	<p>25.950.207-01</p>
	<p><b>Spade Connectors</b> - For fitting to main, auxiliary or coil terminals. Sold in bags of 100. Price each.</p>	<p>CA4-SC11</p>

❶ CA4 contactors with DC coils can be special ordered with integrated diodes (built-in) rather than applying CRD4 to the coil terminals. Integrated diodes improve drop-out times (see page A138 for details). Consult your Sprecher + Schuh representative for more information.

❷ cULus Approved (File #33916).

**Marking Systems**

Component	Description	Pkg. Qty.	Catalog Number
	<b>Label Sheet-</b> 1 sheet with 105 self-adhesive paper labels each, 6 x 17mm	1	CA7-FMS
	<b>Marking Tag Sheet-</b> 1 sheet with 160 perforated paper labels each, 6 x 17mm. To be used with transparent cover.	1	CA7-FMP
	<b>Transparent Cover-</b> To be used with Marking Tag sheets.	100 ❶	CA7-FMC
	<b>Tag Carrier -</b> For marking with Clip-on Tags. See Terminals Section N for complete listing of Clip-on Tags.	100 ❶	CA7-FMA2

**Miscellaneous Accessories**

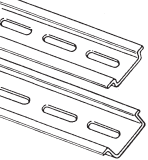
Accessory	Description	Catalog Number
	<b>DIN-rail-</b> 2 meter lengths (6'6")  Top Hat, low profile (package of 20, price per rail) Top Hat, high profile (package of 10, price per rail)	  3F 3AF

❶ Minimum order quantity is one package of 100.  
Price each x 100 = total price.

**Technical Information**

		CA4-9	CA4-12			CA4-9	CA4-12			
<b>Rated Insulation Voltage <math>U_i</math></b>				<b>Wye-Delta (Star Delta)</b>	230V	[A]	21			
to IEC947-1	[V]	500V		50 Hz	240V	[A]	21			
UL/CSA	[V]	600V			400V	[A]	16			
<b>Rated Impulse Voltage <math>U_{imp}</math></b>					415V	[A]	16			
<b>Rated Voltage <math>U_e</math>-Main Contacts</b>					500V	[A]	12			
AC 50/60Hz	[V]	230, 240, 400, 415, 500			230V	[kW]	5.5			
DC	[V]	24, 48, 110, 220, 440			240V	[kW]	5.5			
<b>Operating Frequency for AC Loads</b>		[Hz]	50/60Hz		400V	[kW]	7.5			
					415V	[kW]	7.5			
					500V	[kW]	7.5			
<b>Switching Motor Loads</b>				<b>AC-1 Load, 3Ø Switching</b>	$I_e$	[A]	20			
<b>Standard IEC Ratings</b>				Ambient Temperature 40° C	230V	[kW]	8			
<b>AC-2, AC-3</b>	230	[A]	12		240V	[kW]	8.3			
DOL & Reversing	240V	[A]	12		400V	[kW]	14			
50Hz/60° C	400V	[A]	9		415V	[kW]	14			
	415V	[A]	9		500V	[kW]	17			
	500V	[A]	7							
	230V	[kW]	3.3	Ambient Temperature 60° C	$I_e$	[A]	16			
	240V	[kW]	3.4		230V	[kW]	6.4			
	400V	[kW]	4.3		240V	[kW]	6.7			
	415V	[kW]	4.5		400V	[kW]	11			
	500V	[kW]	4.2		415V	[kW]	12			
					500V	[kW]	14			
<b>UL/CSA</b>				<b>Continuous Current (UL/CSA)</b>						
DOL & Reversing	1Ø	115V	[A]	9.8	9.8	General Purpose Rating (40° C)	Open	[A]	12	12
60Hz		230V	[A]	10	12		Enclosed	[A]	12	12
		115V	[HP]	0.5	0.5					
		230V	[HP]	1.5	2					
		200V	[A]	7.8	11	<b>Lighting Loads</b>	Enclosed	[A]	18	18
		230V	[A]	6.8	9.6	Elec.Dischrg.Lamps-AC-5a,	Open	[A]	14.5	14.5
		460 V	[A]	7.6	11	single compensated				
	3Ø	575 V	[A]	6.1	11	Max. capacitance at	10kA	[µF]	750	750
		200 V	[HP]	2	3	prospective short circuit	20kA	[µF]	400	400
		230 V	[HP]	2	3	current available at the	50kA	[µF]	~	~
		460 V	[HP]	5	7.5	contactor				
		575 V	[HP]	5	10					
<b>Maximum Operating Rate</b>		AC2	[ops/hour]	300	300	<b>Incandescent Lamps</b>				
At 9A for AC3; 20A for AC2/4		AC3	[ops/hour]	600	600	- AC-5b				
Starting time $t_A = 0.25s$		AC4	[ops/hour]	300	300	Electrical endurance~100,000 operations	[A]	9.3	9.3	
<b>AC4 (200,000 Op. Cycles)</b>		230V	[A]	3.9	3.9					
50Hz		240V	[A]	3.9	3.9					
		400V	[A]	3.3	3.3					
		415V	[A]	3.2	3.2					
		230V	[kW]	0.75	0.75					
		240V	[kW]	0.75	0.75					
		400V	[kW]	1.1	1.1					
		415V	[kW]	1.5	1.5					
<b>Max. Operating Rate</b>			[ops/hour]	250	250					

#### Electrical Data

		CA4-9	CA4-12			CA4-9	CA4-12
<b>Switching power transformers AC-6a</b>							
Inrush	= n			<b>Short Circuit Protection of CA4 Without Motor Protection Relays</b>			
Rated transformer current				Max. fuse gG per IEC 947-4-1			
230V	[A]	5.4	5.4	Type 1 Coordination	max.	[A]	25
240V	[A]	5.4	5.4	Type 2 Coordination	max.	[A]	16
400V	[A]	4.1	5.4	Class K5 and RK5 fuses ①	max.	[A]	40
415V	[A]	4.1	5.4	<b>Resistance and Watt Loss <math>I_e</math> AC3</b>			
500V	[A]	3.2	3.2	Resistance per power pole		[mΩ]	5.5
230VAC	[kVA]	2.2	2.2	Watt Loss - 3 power poles		[W]	2.4
240VAC	[kVA]	2.2	2.2	Coil and 3 AC power poles		[W]	3.8
400VAC	[kVA]	2.8	3.7	Coil and 3 DC power poles		[W]	4.9
415VAC	[kVA]	2.9	3.9	<b>Coil Data</b>			
500VAC	[kVA]	2.7	2.7			CA4-9	CA4-12
<b>DC Ratings</b>							
<b>DC-1 Rating at 60°C</b>							
1 Pole		[kW]	~	~			
24VDC	[A]	9	9	AC: 50Hz, 60Hz, 50/60 Hz	Pickup	[x $U_s$ ]	0.85...1.1
48VDC	[A]	6	6		Dropout	[x $U_s$ ]	0.3...0.65
110VDC	[A]	1	1	DC	Pickup	[x $U_s$ ]	0.85...1.1
220VDC	[A]	0.3	0.3		Dropout	[x $U_s$ ]	0.1...0.25
440VDC	[A]	0.1	0.1	<b>Coil Consumption</b>			
2 Pole in Series		[A]	9	9	AC: 50Hz, 60Hz, 50/60 Hz	Pickup	[VA/W]
48VDC	[A]	8	8		Hold-in	[VA/W]	22/20
110VDC	[A]	6	6	DC	Pickup	[W]	2.5
220VDC	[A]	1.2	1.2		Hold-in	[W]	2.5
440VDC	[A]	0.3	0.3	<b>Operating Times</b>			
3 Pole in Series		[A]	9	9	AC: 50Hz, 60Hz, 50/60 Hz	Pickup	[ms]
48VDC	[A]	9	9		Dropout	[ms]	15...40
110VDC	[A]	9	9	with RC Suppressor	Dropout	[ms]	15...25
220VDC	[A]	4	4	DC	Pickup	[ms]	18...40
440VDC	[A]	0.6	0.6		Dropout	[ms]	6...12
<b>Shunt-wound Motors</b>							
Starting, reverse current braking, reversing stepping DC-3, 60°C							
24V	[A]	9	9	with Integ. Suppression	Dropout	[ms]	8...12
3 Poles in series		[A]	6	6	with Diode Suppression	Dropout	[ms]
48/60V	[A]	3	3				35...50
110V	[A]	3	3	<b>Series-wound Motors</b>			
220V	[A]	1.2	1.2	Starting, reverse current braking, reversing stepping DC-5, 60°C			
440V	[A]	0.2	0.2	3 poles in series		[A]	9
<b>Short Time Withstand <math>I_{CW}</math>, 60°C</b>							
10s	[A]	96	96	48/60V	[A]	3	3
				110V	[A]	1	1
				220V	[A]	0.1	0.1
				440V	[A]	~	~

① UL listed combination.





**Mechanical Data**

			CA4-9	CA4-12
<b>Service Life</b>				
Mechanical	AC	[Mil.]	10	
	DC	[Mil.]	20	
Electrical	AC-3(400V)	[Mil.]	0.7	

**Shipping Weights**

AC-CA4	[kg]	0.16
	[Lbs]	0.35
AC-CAU4	[kg]	0.35
	[Lbs]	0.77
DC-CA4	[kg]	0.16
	[Lbs]	0.35
DC-CAU4	[kg]	0.35
	[Lbs]	0.77

**Terminations - Power**

Terminal Type	 Combination Screw Head: Cross, Slotted, Pozidrive		
	1 wire	[mm <sup>2</sup> ]	0.75...2.5
	2 wires	[mm <sup>2</sup> ]	0.75...2.5
	1 wire	[mm <sup>2</sup> ]	0.75...2.5
	2 wires	[mm <sup>2</sup> ]	0.75...2.5
	1 wire	[AWG]	18...14
	2 wires	[AWG]	18...14
Torque Requirement	[Nm]	1...1.5	
	[Lb-in]	7...15	

**Terminations - Control**

Terminal Type	 Combination Screw Head: Cross, Slotted, Pozidrive		
Coils	1 or 2	[mm <sup>2</sup> ]	0.75...2.5
		[AWG]	18...14
Control Modules	1 or 2	[mm <sup>2</sup> ]	0.75...2.5
		[AWG]	18...14
Torque Requirement	[Nm]	1...1.5	
	[Lb-in]	7...15	

**Degree of Protection-contactor** IEC 60529 and DIN 40 050 (with wires installed)

**Protection Against Accidental Contact** Safe from touch by fingers and back-of hand per VDE 0106; Part 100

**Environmental and General Specifications**

**Ambient Temperature**

Storage	-55...+80° C (-67...176° F)
Operation	-25...+60° C (-13...140° F)
Conditioned 15% current reduction after AC-1 at >60° C	-25...+70° C (-13...158° F)

**Altitude at installed site** 2000 meters above sea level per IEC 947-4

**Resistance to Corrosion / Humidity**

Damp-alternating climate: cyclic to IEC 68-2, 56 cycles.  
 Dry Heat: IEC 68-2, +100°C (212°F), relative humidity <50%, 7 days.  
 Damp tropical: IEC 68-2, +40°C (104°F), relative humidity <92%, 56 days.

**Shock Resistance** IEC 68-2: Half sinusoidal shock 11 ms, 30g (in all directions)

**Vibration Resistance** IEC 68-2: Static >2g, in normal position no malfunction <5g





**Operating Position** Refer to Dimension Pages

**Standards** IEC 60947-1/4, EN 60947; UL 508; CSA 22.2, No. 14 SEV1025

**Approvals**

CE, UL, CSA, Germanischer Lloyd, Bureau Veritas, Lloyd's Registry of shipping, Maritime Registry of Shipping

## Auxiliary Contacts

		Built-in Auxiliary Contacts					Add-on Auxiliary Contact Blocks						
<b>Current Switching</b>													
AC-12 lth	at 40°C	[A]	16					10					
	at 60°C	[A]	12					6					
AC-15, switching electromagnetic loads at:		[V]	24...230	240	400	415	500	24...230	240	400	415	500	
		[A]	6	5	2.5	2	1.25	2	2	1	1	0.6	
DC-13, switching DC electromagnets at:		[V]	24	48	110	220	440	24	48	110	22	440	
		[A]	5	0.6	0.45	0.25	0.04	2	0.6	0.45	0.1	0.04	
<b>Low Level Signal Switching</b>													
Contact design			X-stamped					H-bridge, bi-furcated					
Minimum switching recommendation		[V]	17V					17V					
		[mA]	10mA					5mA					
<b>Short-Circuit Protection - gG Fuse</b>													
Type 2 Coordination		[A]	16					10					
<b>Load carrying capacity per UL/CSA</b>													
Rated Voltage	AC	[V]	600 max.					600 max.					
Continuous Rating	40°C	[A]	10 general purpose Heavy pilot duty (A600)					10 general purpose Heavy pilot duty (A600)					
Switching Capacity	AC												
Rated Voltage	DC	[V]	600 max.					600 max.					
Continuous Rating	DC		Standard pilot duty (Q600)					Standard pilot duty (Q600)					
Switching Capacity	DC												
<b>Terminals</b>													
Terminal Type													
Maximum Wire Size per IEC 947-1													
	Flexible with Wire-End Fernule	1 Conductor	[mm <sup>2</sup> ]	0.75...2.5					0.75...2.5				
		2 Conductor	[mm <sup>2</sup> ]	0.75...2.5					0.75...2.5				
	Solid/Stranded-Conductor	1 Conductor	[mm <sup>2</sup> ]	0.75...2.5					0.75...2.5				
		2 Conductor	[mm <sup>2</sup> ]	0.75...2.5					0.75...2.5				
Recommended Tightening Torque			[Nm]	1...15					1...1.5				
Max. Wire Size per UL/CSA			[AWG]	18...14					18...14				
Recommended Tightening Torque			[lb-in]	7...15					7...15				

## CRZE4/CRZY4 Electronic Timers

<b>Permissible voltage</b>	
CRZE4 (AC or DC)	110V (-23%) - 250V (+10%)
CRZY4 (AC only)	110V (-23%) - 120V (+10%)
	110V (-23%) - 250V (+10%)
<b>Voltage Drop</b>	5V max
<b>Load current for reliable operation</b>	10mA min
<b>Load current</b>	
20°C	600mA
40°C	440mA
55°C	320mA
<b>Leakage current at 220V</b>	
CRZE4	5mA
CRZY4	"Y" 17mA, "D" 6mA
<b>Reset time</b>	200ms
<b>Voltage failure duration having no influence on timing sequence</b>	
CRZE4	15ms
CRZY4	20ms
<b>Repeat accuracy</b>	±5%
<b>Time interval for start commands</b>	
CRZE4	1.4 x set time
CRZY4	2 x set time
<b>Ambient Temperature</b>	
Storage	-40°C to +80°C
Operation	-20°C to +55°C

## Contact Ratings (Per NEMA/UL A600 & Q600)

Standard	Circuit Voltage	Make (Amps/VA)	Break (Amps/VA)	Continuous Amps
A600	120AC	60A/7200VA	60A/720VA	10
	240AC	30A/7200VA	30A/720VA	
	480AC	15A/7200VA	15A/720VA	
	600AC	12A/7200VA	12A/720VA	
Q600	125DC	0.55/69VA	0.55/69VA	2.5
	250DC	0.27/69VA	0.27/69VA	
	301-600DC	0.1A/69VA	0.1A/69VA	

### Positively-Guided Contacts

SUVA Certified

- Contactor contacts among each other.
- Auxiliary contact block contacts next to each other.
- Contacts between contactor and auxiliary contact block not positively guided.

① See Section G for additional details.

**Determining Contact Life**

To determine the contactor's estimated electrical life, follow these guidelines:

1. Identify the appropriate Utilization Category from Table A.
2. On the following pages, choose the graph for the Utilization Category selected.

3. Locate the Rated Operational Current ( $I_e$ ) along the bottom of the chart and follow the graph lines up to the intersection of the appropriate contactor's life-load curve.
4. Read the estimated contact life along the vertical axis.

**Table A – IEC Special Utilization Categories, AC Ratings ①**

	Category	Typical Applications	Rated Current	Conditions for testing electrical life						Ops.	Conditions for testing making and breaking capacity						Ops.
				Make			Break				Make			Break			
				$I/I_e$	$U/U_e$	$\cos$	$I_c/I_e$	$U_r/U_e$	$\cos$		$I/I_e$	$U/U_e$	$\cos$	$I_c/I_e$	$U_r/U_e$	$\cos$	
<b>CONTACTORS</b>	<b>AC-1</b>	Non-inductive or slightly inductive loads, resistance furnaces	All values	1	1	0.95	1	1	0.95	6000	1.5	1.05	0.8	1.5	1.05	0.8	50
	<b>AC-2</b>	Slip-ring motors: Starting, plugging	All values	2	1.05	0.65	2	1.05	0.65	6000	4	1.05	0.65	4	1.05	0.65	50
	<b>AC-3</b>	Squirrel-cage motors: Starting, switching off motors during running	$I_e \leq 17\text{Amp}$	6	1	0.65	1	0.17	0.65	6000	10	1.1	0.65	8	1.1	0.65	50
			$17\text{Amp} < I_e \leq 100\text{Amp}$	6	1	0.35	1	0.17	0.35		10	1.1	0.35	8	1.1	0.35	
			$I_e > 100\text{Amp}$	6	1	0.35	1	0.17	0.35		8 ②	1.1	0.35	6 ③	1.1	0.35	
	<b>AC-4</b>	Squirrel-cage motors: Starting, plugging, inching ④	$I_e \leq 17\text{Amp}$	6	1	0.65	6	1	0.65	6000	12	1.1	0.65	10	1.1	0.65	50
			$17\text{Amp} < I_e \leq 100\text{Amp}$	6	1	0.35	6	1	0.35		12	1.1	0.35	10	1.1	0.35	
			$I_e > 100\text{Amp}$	6	1	0.35	6	1	0.35		10 ④	1.1	0.35	8 ②	1.1	0.35	
<b>AC-5a</b>	Switching of electric discharge lamp control		2	1.05	0.45	2	1.05	0.45	6000	3	1.05	0.45	3	1.05	0.45	50	
<b>AC-5b</b>	Switching of incandescent lamps		1	1.05		1	1.05			1.5	1.05		1.5	1.05		50	
<b>AC-6a</b>	Switching of transformers									Rating derived from AC-3 rating (x 0.45)							
<b>AC-6b</b>	Switching of capacity banks									Depends on circuit conditions of application							
<b>CONTROL DEVICES</b>	<b>AC-12</b>	Control of resistive loads and solid state loads with isolation by opto couplers	All values	1	1	0.9	1	1	0.9	6050							
	<b>AC-13</b>	Control of solid state loads with transformer isolation		2	1	0.65	1	1	0.65	6050	10	1.1	0.65	1.1	1.1	0.65	10
	<b>AC-14</b>	Control of small electromagnetic loads	72 VA	6	1	0.3	1	1	0.3	6050	6	1.1	0.7	6	1.1	0.7	10
	<b>AC-15</b>	Control of electromagnetic loads	72 VA	10	1	0.3	1	1	0.3	6050	10	1.1	0.3	10	1.1	0.3	10
	<b>AC-20</b>	Connecting and disconnecting under no load conditions		No testing required													
<b>SWITCHES</b>	<b>AC-21</b>	Switching of resistive loads, including moderate loads	All values	1	1	0.95	1	1	0.95	10000	1.5	1.05	0.95	1.5	1.05	0.95	5
	<b>AC-22</b>	Switching of mixed resistive & inductive loads, including moderate overloads	All values	1	1	0.8	1	1	0.8	10000	3	1.05	0.65	3	1.05	0.65	5
	<b>AC-23</b>	Switching of motor loads or other highly inductive loads	All values	1	1	0.65	1	1	0.65	10000	10	1.05	0.45	8	1.05	0.45	5

**Legend**

- $U_e$**  Rated operational voltage
- $U$**  Voltage before make
- $U_r$**  Recovery voltage
- $I_e$**  Rated operational current
- $I$**  Making current
- $I_c$**  Breaking current
- $L$**  Inductance of test circuit
- $R$**  Resistance of test circuit

- ① Utilization categories and test conditions for AC & DC. For contactors according to IEC 158-1, starters according to IEC 292-1 ... 4 and control switches according to IEC 337-1 and IEC 337-1A.
- ② With a minimum value of 1000A for  $I$  or  $I_c$ .
- ③ With a minimum value of 800A for  $I_c$ .
- ④ With a minimum value of 1200A for  $I$ .
- ⑤ Plugging is understood as stopping or reversing the motor rapidly by reversing the motor primary connections while the motor is running. Inching [or jogging] is understood as energizing a motor once or repeatedly for short periods to obtain small movements of the driven mechanism.

**Determining Contact Life**

To determine the contactor's estimated electrical life, follow these guidelines:

1. Identify the appropriate Utilization Category from Table A.
2. On the following pages, choose the graph for the Utilization Category selected.

3. Locate the Rated Operational Current ( $I_e$ ) along the bottom of the chart and follow the graph lines up to the intersection of the appropriate contactor's life-load curve.
4. Read the estimated contact life along the vertical axis.

CA4 **Table A – IEC Special Utilization Categories, DC Ratings ①**

Category	Typical Applications	Rated Current	Conditions for testing electrical life						Ops	Conditions for testing making and breaking capacity						Ops
			Make			Break				Make			Break			
			$I/I_e$	$U/U_e$	$\cos$	$I_c/I_e$	$U_r/U_e$	$\cos$		$I/I_e$	$U/U_e$	$\cos$	$I_c/I_e$	$U_r/U_e$	$\cos$	
<b>DC-1</b>	Non-inductive or slightly inductive loads, resistance furnaces	All values	1	1	1	1	1	1		1.5 ②	1.1 ②	1 ②	1.5 ②	1.1 ②	1 ②	
<b>DC-2</b>	Shunt-motors: Starting, switching off motors during running	All values	2.5	1	2	1	0.1	7.5		4	1.1	2.5	4	1.1	2.5	
<b>DC-3</b>	Shunt-motors: Starting, plugging, inching	All values	2.5	1	2	2.5	1	2		4	1.1	2.5	4	1.1	2.5	
<b>DC-4</b>	Series-motors: Starting switching off motors during running	All values	2.5	1	7.5	1	0.3	10		4	1.1	15	4	1.1	15	
<b>DC-5</b>	Series-motors: Starting, plugging, inching	All values	2.5	1	7.5	2.5	1	7.5		4	1.1	15	4	1.1	15	
<b>DC-15</b>	Electromagnets for contactors, valves, solenoid actuators	All values	1	1	6 x P ③	1	1	6 x P ③		1.1	1.1	6 x P ③	1.1	1.1	6 x P ③	

**Legend**

- $U_e$**  Rated operational voltage
- $U$**  Voltage before make
- $U_r$**  Recovery voltage
- $I_e$**  Rated operational current
- $I$**  Making current
- $I_c$**  Breaking current
- $L$**  Inductance of test circuit
- $R$**  Resistance of test circuit

① Utilization categories and test conditions for AC & DC. For contactors according to IEC 158-1, starters according to IEC 60292-1 ... 4 and control switches according to IEC 337-1 and IEC 337-1A.

② Only according to VDE.

③  $P = U_e \times I_e$  rated power [W]. The value "6 x P" has been derived from an empiric relationship which covers most magnetic loads for DC up to an upper limit of  $P = 50W$ .

**Life-Load Curves**

- Locate the Rated Operational Current ( $I_e$ ) along the bottom of the chart and follow the graph lines up to the intersection of the appropriate contactor's life-load curve.
- Read the estimated contact life from the vertical axis.

**INSTRUCTIONS ON  
"HOW TO READ"  
LIFE CURVES CAN BE  
FOUND IN THE FRONT  
OF SECTION A**

**AC-1, AC3**  
(400...460V AC)

AC-1 Non- or slightly inductive loads, resistance furnaces; ①  
AC-3 Switching of squirrel-cage motors while starting  
 $U_e = 400...415$  VAC

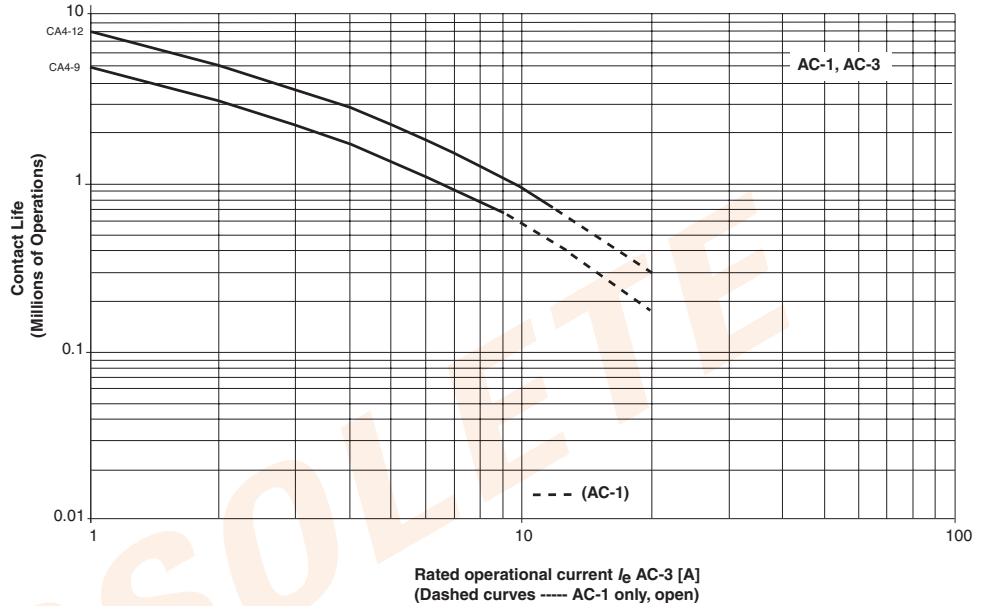

**AC-4**  
(400...460V AC)

AC-4 Stepping of squirrel-cage motors ①  
 $U_e = 400...415$  VAC

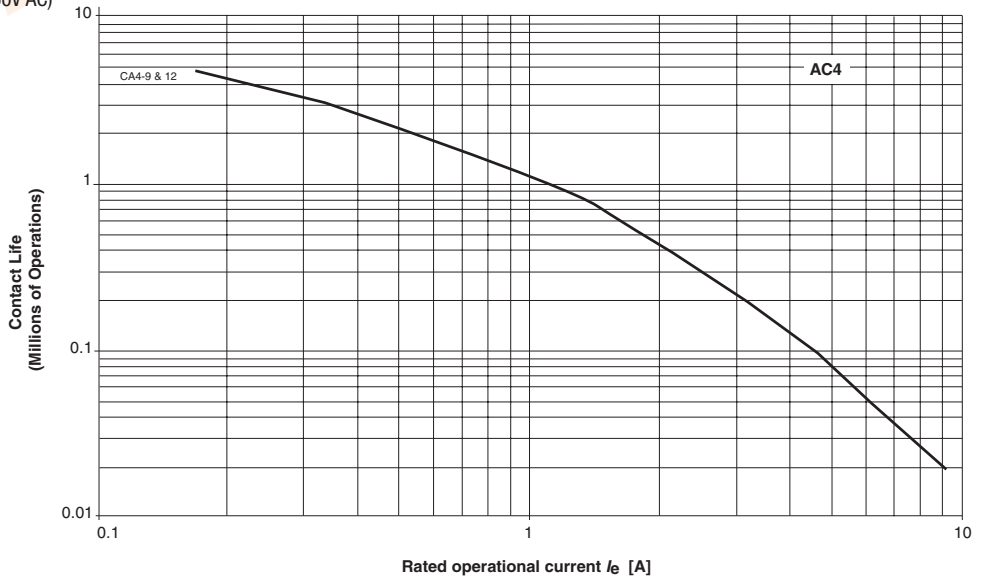

**NOTE:** The life-load curves shown here are based on Sprecher+Schuh tests according to the requirements defined in IEC 60947-4-1. Since contact life in any given application is dependent on environmental conditions and duty cycle, actual application contact life may vary from that indicated by the curves shown here.

① For electrical life at 460V (60Hz), reduce the values from the 400/415VAC (50Hz) chart by 5%.

**Series CA4 & Series CAU4 (Contactors & Reversing Contactors)**

- Dimensions are in millimeters (inches)
- Dimensions not intended for manufacturing purposes

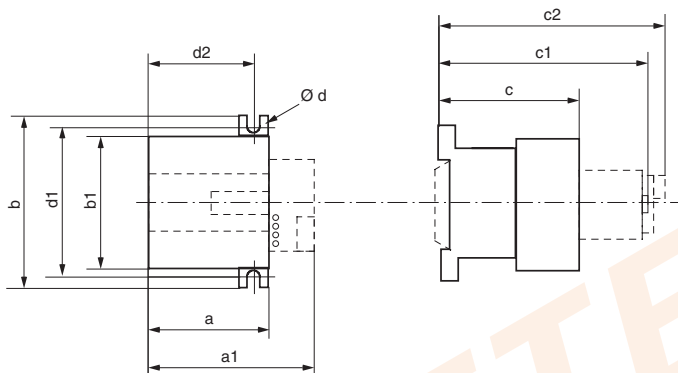

Type	a	a1	b	b1	c	c1	c2	d	d1	d2
<b>CA4-9 &amp; 12</b>	45 (1-25/32)	67 (2-21/32)	56 (2-3/16)	47 (1-14/16)	48 (1-29/32)	74 (2-15/16)	77 (3-1/16)	4.2 (11/64)	50 (1-31/32)	40 (1-9/16)

**Reversing Contactors & Accessories**

Contactor with...	Dim. [mm]	Dim. [inches]
reversing with mechanical interlock	a+a	a+a
with aux. contact block	c1	c1
with timer	on contactor	c2
	at side of contactor	a1
with neutral terminal	at side of contactor	a+20
with protection element		a+1-25/32
with nameplate	c..+5	c..+3/16

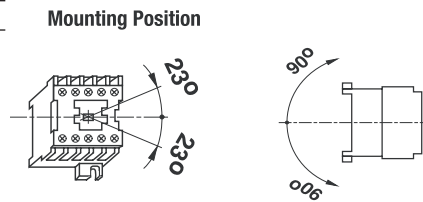

**Series CAT4 & Series CAUT4 (Starters & Reversing Starters)**

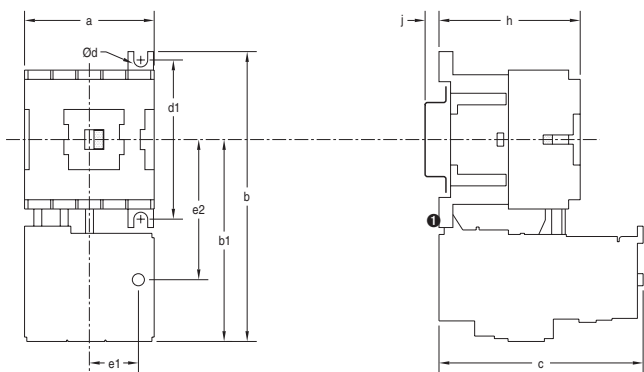

Type	a	b	b1	c	e2	d1	h	j	d
<b>CA4-9(12)+CEP7-A/M/S</b>	45 (1-25/32)	107 (4-7/32)	83 (3-9/32)	66.6 (2-5/8)	50 (1-31/32)	50 (1-31/32)	48.2 (1-29/32)	2 (3/32)	Two $\phi$ 4.2 (Two 11/64)
<b>CA4-(12) +CT4</b>	45 (1-25/32)	98 (3-7/8)	70 (2-3/4)	86 (3-13/32)	40 (1-19/32)	50 (1-31/32)	48.2 (1-29/32)	2 (3/32)	Two $\phi$ 4.2 (Two 11/64)

**Reversing Starters**

Contactor	Dim. [mm]	Dim. [inches]
reversing with mechanical interlock	a+a	a+a

❶ Provision for mounting on a top hat rail (EN 50 022). Top hat and G-rail mounting not possible when using mechanical interlock.

**CT4 Thermal Overload Relays, Manual Reset ①**





Overload Relay	Directly Mounts to Contactor...	Adjustment Ranges [A]	Trip Class 10
			Catalog Number
 <p>CT4-9</p>	CA4-9	0.10...0.15	CT4-0.15
		0.15...0.23	CT4-0.23
		0.23...0.35	CT4-0.35
		0.35...0.55	CT4-0.55
		0.55...0.8	CT4-0.80
		0.8...1.2	CT4-1.2
		1.2...1.8	CT4-1.8
		1.8...2.7	CT4-2.7
		2.7...4	CT4-4.0
		4...6	CT4-6.0
		6...7.7	CT4-7.7
		7.5...9	CT4-9.0
	CA4-12	8.8...10.5	CT4-10.5
		10.4...12	CT4-12.0

**CT4 Thermal Overload Relay Accessories**





Accessory	Description	For Use with...	Catalog Number
	Auxiliary Contact Block - 1 N.O. alarm contact	ACT4	CT3K-P-10

① Separately mounted overload not available.

#### Electrical Data

		CT4-9	CT4-12
<b>Main Circuits</b>			
<b>Rated Insulation Voltage <math>U_i</math></b>			
UL	[V]	600	600
CSA	[V]	690	690
CULus	[V]		
<b>Rated Impulse Strength <math>U_{imp}</math></b>		[kV] 6	6
<b>Rated Operating Voltage <math>U_e</math></b>		[V] 690	690
<b>Overvoltage Category/Degree of Contamination</b>		III/3	III/3
<b>Terminal Cross-Sections</b>			
<b>Terminal Type</b>			
			
		M3.5	M3.5
<b>Terminal Screws</b>			
	Flexible with Wire End Ferrule	[mm <sup>2</sup> ] 2 x (1...2.5)	2 x (1...2.5)
	Solid Conductor Stranded	[mm <sup>2</sup> ] 1 x (1.5...4)	1 x (1.5...4)
		[mm <sup>2</sup> ] 2 x (1...2.5)	2 x (1...2.5)
<b>Max. Wire Size per UL/CSA</b>		[AWG] 2 x (14...10)	2 x (14...10)
<b>Recommended Torque</b>		[Nm] 1.4...2.0	1.4...2.0
		[lb-in] 12...20	12...20
<b>Pozidrive Screwdriver</b>		Size 2	2
<b>Slotted Screwdriver</b>		mm 1 x 6	1 x 6

#### Control Circuit

		CT4-9	CT4-12
<b>Rated Insulation Voltage <math>U_i</math></b>		[V] 500	500
<b>Rated Operating Voltage <math>U_e</math></b>		[V] 500	500
<b>Rated Operating Current <math>I_e</math></b>			
AC-15	220...240V	[A] ~	~
	380...480V	[A] ~	~
<b>Conventional Thermal Current</b>		[A] ~	~
<b>Terminations</b>			
<b>Terminal Type</b>			
			
		M 3.5	M 3.5
	Flexible with Wire End Ferrule	[mm <sup>2</sup> ] 2 x (0.75...2.5)	2 x (0.75...2.5)
	Solid Conductor Stranded	[mm <sup>2</sup> ] 2 x (0.75...2.5)	2 x (0.75...2.5)
		[mm <sup>2</sup> ] 2 x (0.75...4)	2 x (0.75...4)
<b>Max. Wire Size per UL/CSA</b>		[AWG] 2 x (18...14)	2 x (18...14)
<b>Recommended Torque</b>		[Nm] 1.2	1.2
		[lb-in] 11	11
<b>Pozidrive Screwdriver</b>		Size 2	2
<b>Slotted Screwdriver</b>		mm 1 x 6	1 x 6

#### General Data

		CT4-9 / CT4-12	Temperature Compensation	Continuous (Temperature Range -5...+40°C per IEC 947, EN60947; PTB: -5...+50°C)
<b>Weight</b>	[kg (oz)]	0.15 (4.8)	<b>Shock Resistance</b>	10ms sinusoidal shock [G] 10
<b>Standards</b>		IEC 947, EN 60 947, DIN VDE 0660	<b>Type of Protection</b>	IP00
<b>Approvals</b>		CE, UL, CSA, PTB	in connected state	IP2X (in a connected state)
<b>Corrosion Resistance</b>		Humid/Warm, Constant, per DIN, IEC 68, Part 2-3	Finger Protection	Finger and back of hand safe (VDE 0106, Part 100)
		Humid/Warm, Cyclic, per DIN, IEC 68, Part 2-30		
<b>Ambient Temperature</b>				
Open		-25...+60°C (-13...140°F)		
Enclosed		-25...+40°C (-13...104°F)		

Short Circuit Coordination - CT4 ❶

Mounting on Contactor	Catalog Number	Adjustment Ranges [A]	gL Back-Up Fuses max. I <sub>g</sub> [A]	
			Type 1 Coordination	Type 2 Coordination
CA4-9	CT4-0.15	0.1...0.15	25	1
	CT4-0.23	0.15...0.23	25	1
	CT4-0.35	0.23...0.35	25	2
	CT4-0.55	0.35...0.55	25	2
	CT4-0.8	0.55...0.8	25	2
	CT4-1.2	0.8...1.2	25	4
	CT4-1.8	1.2...1.8	25	4
	CT4-2.7	1.8...2.7	25	6
	CT4-4	2.7...4	25	10
	CT4-6	4...6	25	~
	CT4-7.7	6...7.7	25	16 ❷
	CT4-9	7.5...9	25	16 ❷
	CA4-9...CA4-12	CT4-10.5	8.8...10.5	25
CT4-12		10.4...12	25	~

0  
Motor Protection  
CT4

OBSOLETE

❶ I = 50kA, except as indicated.  
❷ I<sub>q</sub> = 25kA for this test.

**Tripping Characteristics**

These tripping characteristics comply with IEC 947 and are the mean values of the scatter bands at 20°C ambient temperature starting from the cold state. Tripping time is

a function of operating current. In equipment at operating temperature, the tripping time of the overload relay falls to approximately 1/4 of the read value.

**0.1...2.7A**

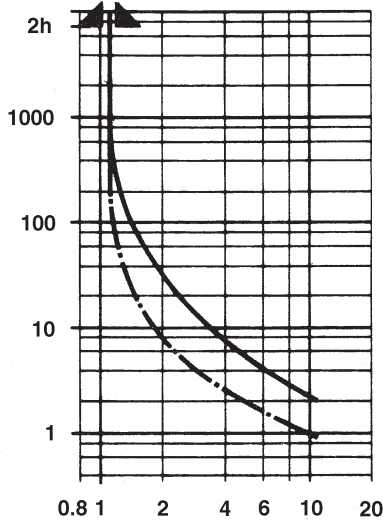

**2.7...17.5A**

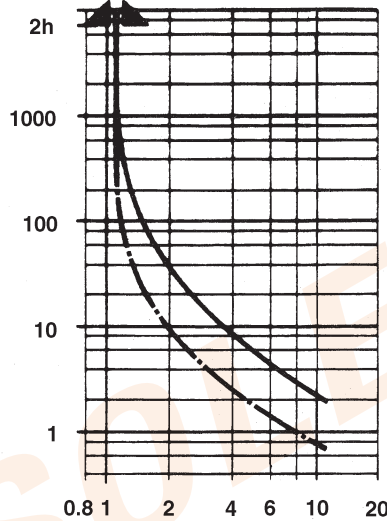

**Time/Current Characteristics of CT4 & CT7K Thermal Overload Relays**

Mean value of tolerance bands, heated in three phases. **Solid curves** indicate performance of cold relay. **Dashed curves** indicate performance in operationally warm state (loaded with the set current).

**Tolerance:** trip time ±20% (±10 for current).

**Function Limits and Temperature Compensation:** from -25°C...+70°C.

**Tripping Limits:** specified in IEC60947-4 for -5°C...+40°C are satisfied in range -20°C...+60°C.

**Two Phase Loading (phase failure):** Trip limits 1.05...1.25 of set current  $I_{ef}$  (1.05...1.32  $I_{ef}$  is permissible according to IEC 60947-4). For motors up to 10kW, the two-phase trip at max. 1.25  $I_{ef}$  guarantees heat build-up limitation to the value  $I_{ef}^2$  which occurs in the event of a 3-phase trip at 1.2  $I_{ef}$ .

**Connection Diagrams**

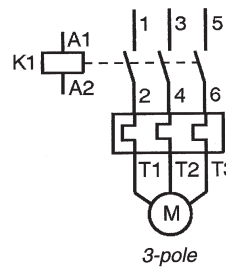
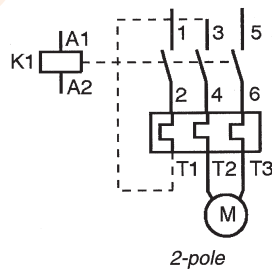
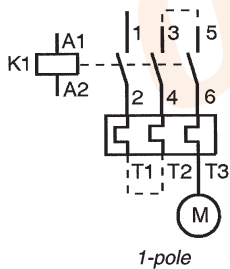

**Series CT4 (Mounting to CA4 Contactor)**

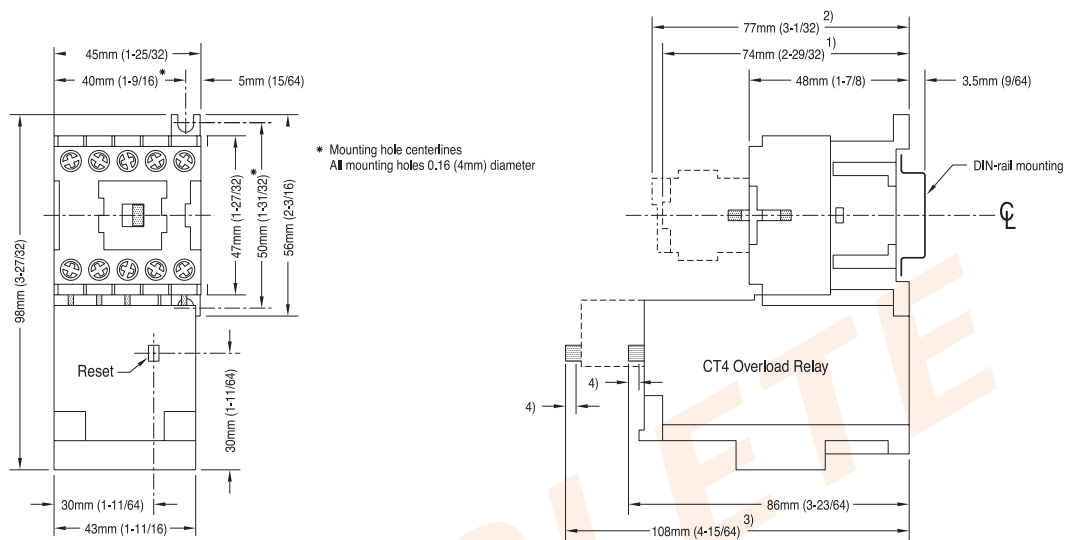

- 1) With aux contact block CA4-P.
- 2) With timing elements CRZE4, CRZY4.
- 3) With aux contact CT3K-P-10 on overload.
- 4) Overload reset: 0.09 (2.3mm) minimum travel.

- Dimensions are in millimeters (inches)
- Dimensions not intended for manufacturing purposes

# CS4 Industrial Control Relays

## The miniature relay system with big advantages



The CS4C relay (for DC operation) with 4 pole auxiliary contact block



Despite increasing complexity, control systems and installations must become increasingly compact. And the CS4 Miniature Relay System packs maximum performance into minimum space.

### Small but rugged

Sprecher + Schuh has subjected this relay series to monitored endurance tests that demonstrate their ruggedness. Under normal duty, CS4 contacts have a maximum electrical life of 3,500,000 operations, while the AC magnet system has a mechanical life of 10,000,000 operations.

The coil is designed for absolute undervoltage reliability. Undervoltages that do not cause the contactor to close can be withstood indefinitely without damage.

The body of the device is sturdy as well. The front housing, containing the phase partitions and screwdriver guides, is manufactured in one piece. Front and rear housing are then joint fitted together.

### Superior Contact Reliability

The standard CS4 relay utilizes x-stamped contact technology that reliably switches signals as low as 17V @ 25mA. Some PLC and other electronic circuits operate at signals as low as 17V @ 5mA. These applications require the CS4-B relay with H-bridge, bifurcated contacts.

The bifurcated H-bridge design divides each movable contact into two sections at the tip of the spanner which provides a higher degree of reliability for low signal applications.

### Mechanically linked contacts for safety

CS4 control relays are perfect for fail-safe control circuits. An interlock contact design, which maintains minimum 0.3mm clearance, prevents the NC contact from reclosing if the NO contact is welded when in operation. (This feature includes the base contact



poles only and does not extend to the front mounted auxiliary contacts.)

### Accessories require no additional panel space

The entire CS4 system is logically engineered. Auxiliary contact blocks and timing elements are modular and snap-on without increasing the CS4's original width of 45mm. Also, due to its sideways switching movement, the basic relay has the same low profile whether an AC or DC operating magnet is used. This permits the use of enclosures with shallow mounting depths. Once the CS4 is installed, all auxiliary contact blocks can be snapped on or removed without changing any existing wiring.

### Auxiliary components provide flexibility



CS4 auxiliary components allow you to convert the basic four pole relay up to an 8 pole relay.

### Effortless installation

CS4 relays are DIN-rail mountable for instant installation and modification. Fittings are also included for base mounting. All terminals are clearly marked and shipped in the open position for installation with either manual or power screwdrivers. Using self-adhesive labels, paper tags or plastic clip-on tags.

The entire line is UL Listed and CSA Certified and offers finger and back of hand protection to the strictest international standards.

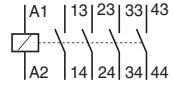
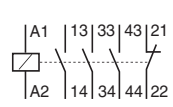
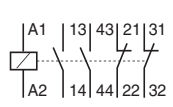
### CS4 Complete Assemblies - 4 & 6 Pole ☉

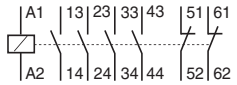
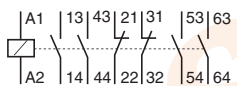
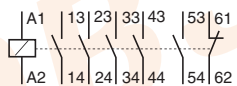
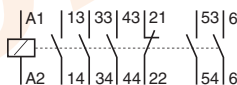
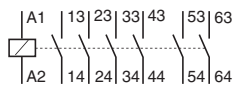
CS4 Relay	Contact Arrangement and Numbering	Contacts		AC Operation	DC Operation
		NO	NC	Catalog Number	Catalog Number
		4	0	CS4-40E-*	CS4C-40E-*
		3	1	CS4-31Z-*	CS4C-31Z-*
		2	2	CS4-22Z-*	CS4C-22Z-*
		4	2	CS4-42E-*	CS4C-42E-*
		4	2	CS4-42X-*	CS4C-42X-*
		5	1	CS4-51E-*	CS4C-51E-*
		5	1	CS4-51X-*	CS4C-51X-*
		6	0	CS4-60E-*	CS4C-60E-*

### A.C. Coil Codes ☉

A.C. Coil Code	Voltage Range	
	50 Hz	60 Hz
<b>24</b>	24V	24V
<b>48</b>	48V	48V
<b>120</b>	110V	110V-120V
<b>240</b>	220V-230V	230V-240V
<b>380</b>	400V-415V	380V-400V

### D.C. Coil Codes

D.C. Coil Code	Voltage
<b>24D</b> ☉	24VDC
<b>48D</b>	48VDC
<b>110D</b>	110VDC
<b>220D</b>	220VDC

### Contact Ratings (Per UL508/NEMA A600 & Q600)

Standard	Circuit Voltage	Make (Amps/VA)	Break (Amps/VA)	Continuous Amps
<b>A600</b>	120AC	60A/7200VA	6A/720VA	10
	240AC	30A/7200VA	3A/720VA	
	480AC	15A/7200VA	1.5A/720VA	
	600AC	12A/7200VA	1.2A/720VA	
<b>Q600</b>	125DC	0.55A/69VA	0.55A/69VA	2.5
	250DC	0.27A/69VA	0.27A/69VA	
	301-600DC	0.1A/69VA	0.1A/69VA	



### Ordering Instructions

- Specify catalog number
- Replace (\*) with Coil Code

Refer to tables above

- The coil codes shown are for the most commonly stocked items. Contact your Sprecher + Schuh representative to determine if other voltages, i.e., 12, 208, 480 and 575V are on-hand or can be specially ordered in quantity.
- Integrated diode surge suppressor coils available. Order coil code **24DD** and add \$25 to list price. Ex: CS4C-40E-**24D** becomes CS4C-40E-**24DD**.
- CS4(B) relays are positively guided for 4 main poles. Restrictions apply when using auxiliary contacts.

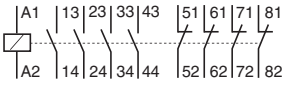
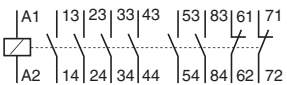
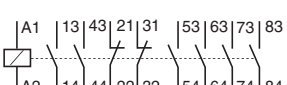
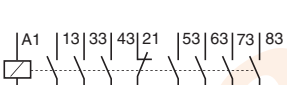
### CS4 Complete Assemblies - 8 Pole ③

CS4 Relay	Contact Arrangement and Numbering	Contacts		AC Operation	DC Operation
		NO	NC	Catalog Number	Catalog Number
		4	4	<b>CS4-44E-*</b>	<b>CS4C-44E-*</b>
		6	2	<b>CS4-62Z-*</b>	<b>CS4C-62Z-*</b>
		6	2	<b>CS4-62X-*</b>	<b>CS4C-62X-*</b>
		7	1	<b>CS4-71X-*</b>	<b>CS4C-71X-*</b>
		8	0	<b>CS4-80E-*</b>	<b>CS4C-80E-*</b>

### A.C. Coil Codes ①

A.C. Coil Code	Voltage Range	
	50 Hz	60 Hz
<b>24</b>	24V	24V
<b>48</b>	48V	48V
<b>120</b>	110V	110V-120V
<b>240</b>	220V-230V	230V-240V
<b>380</b>	400V-415V	380V-400V

### D.C. Coil Codes

D.C. Coil Code	Voltage
<b>24D ②</b>	24VDC
<b>48D</b>	48VDC
<b>110D</b>	110VDC
<b>220D</b>	220VDC

### Contact Ratings (Per UL508/NEMA A600 & Q600)

Standard	Circuit Voltage	Make (Amps/VA)	Break (Amps/VA)	Continuous Amps
<b>A600</b>	120AC	60A/7200VA	6A/720VA	10
	240AC	30A/7200VA	3A/720VA	
	480AC	15A/7200VA	1.5A/720VA	
	600AC	12A/7200VA	1.2A/720VA	
<b>Q600</b>	125DC	0.55A/69VA	0.55A/69VA	2.5
	250DC	0.27A/69VA	0.27A/69VA	
	301-600DC	0.1A/69VA	0.1A/69VA	

### Ordering Instructions

- Specify catalog number
- Replace (\*) with Coil Code

Refer to tables above

- ① The coil codes shown are for the most commonly stocked items. Contact your Sprecher + Schuh representative to determine if other voltages, i.e., 12, 208, 480 and 575V are on-hand or can be specially ordered in quantity.
- ② Integrated diode surge suppressor coils available. Order coil code **24DD** and add \$25 to list price. Ex: CS4C-44E-**24D** becomes CS4C-44E-**24DD**.
- ③ CS4(B) relays are positively guided for 4 main poles. Restrictions apply when using auxiliary contacts.

**CS4-B Complete Assemblies - 4 Pole (Bifurcated contacts for low level signals) ①②**

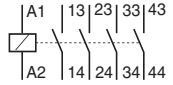
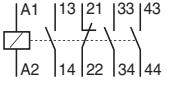
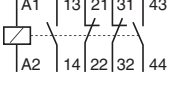
CS4 Relay	Contact Arrangement and Numbering	Contacts		AC Operation	DC Operation
		NO	NC	Catalog Number	Catalog Number
		4	0	CS4-B40E-24	CS4C-B40E-24D
		3	1	CS4-B31E-24	CS4C-B31E-24D
		2	2	CS4-B22E-24	CS4C-B22E-24D







**Contact Ratings (Per UL508/NEMA A300 & Q300)**

Standard	Circuit Voltage	Make (Amps/VA)	Break (Amps/VA)	Continuous Amps
A300	120AC	60A/7200VA	6A/720VA	10
	240AC	30A/7200VA	3A/720VA	
Q300	125DC	0.55A/69VA	0.55A/69VA	2.5
	250DC	0.27A/69VA	0.27A/69VA	



**NOTE:** Our standard CS4 relay utilizes x-stamped contact technology that reliably switches signals as low as 17V @ 25mA. Some PLC and other electronic circuits operate at signals as low as 17V @ 5mA. These applications require Sprecher + Schuh's CS4-B relay with H-bridge, bifurcated contacts.

① CS4-B low level signal relays are only available with 24V coils (AC or DC).  
 ② CS4/(B) relays are positively guided for 4 main poles. Restrictions apply when using auxiliary contacts.

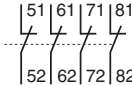
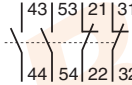
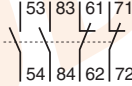
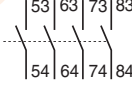
### Auxiliary Contact Blocks (2 & 4 Pole) ①





Auxiliary Contact Blocks	Contact Arrangement	Catalog Number
		CA4-P02
		CS4-P02
		CA4-P11
		CS4-P11
		CS4-P20
		CS4-P04
		CA4-P22
		CS4-P22
		CS4-P40

### Control Modules

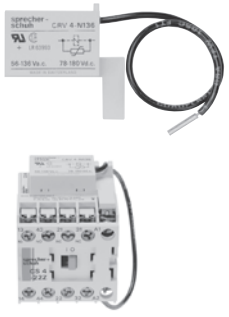

Module	Description	For use with...	Connection Diagrams	Function	Catalog Number
	<b>Electronic Timing Module – ON-Delay</b> The relay is energized at the end of the delay time.	CS4 all		110...250V 50/60Hz  0.1...3 sec. 1...30 sec.	<b>CRZE4-3S</b> <b>CRZE4-30S</b>

① Auxiliary contact ratings per UL 508/NEMA (A600/Q600).

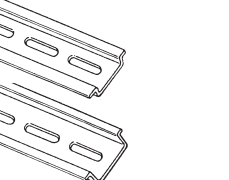
**Accessories**

Accessory	Product Description	Catalog Number
	<p><b>Surge Suppressor CRC4</b> For limiting voltage spikes when switching off coil. Coil itself provides sufficient limitation at voltages over 240 volts.</p> <p>RC Link (Type CRC4...): 24-48 VAC 110-280 VAC</p> <p>Diode Link (Type CRD4...): 12-250 VDC</p> <p>Varistor Link (Type CRV4...): 12-55 VAC/12-77 VDC 56-136 VAC/78-180 VDC 137-277 VAC/181-350 VDC</p>	<p>25.950.121-01 25.950.121-02</p> <p>25.950.123-02</p> <p>25.950.122-01 25.950.122-02 25.950.122-03</p>
	<p><b>Mechanical Interlock Kit</b> For CS4(B) relays with AC coil. Not for use with DC coils.</p>	<p>25.951.301-01</p>
	<p><b>Adaptor</b> For mounting CRZE4 and CRZY4 Electronic Timers to DIN Rails.</p>	<p>25.950.207-01</p>
	<p><b>Spade Connectors -</b> Dual stab for coil terminals (0.250 inch) Package quantity 20</p>	<p>CA7-SC2</p>
	<p><b>DIN-rail</b> - 2 meter lengths (≈6' 6") Top Hat, low profile (price per rail) Top Hat, high profile (price per rail)</p>	<p>3F 3AF</p>

**Marking Systems**

Component	Description	Pkg. Qty.	Catalog Number
	<b>Label Sheet -</b> 1 sheet with 105 self-adhesive paper labels each, 6 x 17mm	1	CA7-FMS
	<b>Marking Tag Sheet -</b> 1 sheet with 160 perforated paper labels each, 6 x 17mm. To be used with transparent cover.	1	CA7-FMP
	<b>Transparent Cover -</b> To be used with Marking Tag Sheets.	100 ①	CA7-FMC
	<b>Tag Carrier -</b> For marking with Series V7 Clip-on Tags.	100 ①	CA7-FMA2

OBSOLETE

① Minimum order quantity is one package of 100. Price each x 100 = total price.

**Technical Information**

			CS4	CS4-B	Auxiliary Contacts
			A600, Q600	A300, Q300	A600, Q600
<b>Electrical</b>					
<b>Contact Ratings — NEMA</b>					
<b>Contact Ratings — IEC</b>					
<b>AC-15</b> (solenoids, contactors) at rated voltage IEC 947, EN 60947	12...120V	[A]	10	2.5	10
	220...240V	[A]	5	2.0	5
	360...400V	[A]	2.5	2.0	2.5
	480...500V	[A]	1.25	2.0	1.25
<b>AC-1</b> (Non-inductive, or slightly inductive loads, resistance furnaces) IEC947, EN 60947	40°C	[A]	16	10	16
	60°C	[A]	12	6	12
<b>AC-2, AC-3, AC-4</b> (switching 3Ø motors)	230V	[A]	5	5	~
	400V	[A]	3.7	3.7	~
	500V	[A]	2.8	2.8	~
<b>Low Level Signal Switching</b>					
Contact design			X-stamped	H-bridge bi-furcated	H-bridge bi-furcated
Minimum switching recommendation			17V 25mA	17V 5mA	17V 5mA
<b>Short Circuit Protection afforded by relay</b>					
Coordination Type 2 acc. IEC 947-4-1	Fuse gG	[A]	16	16	~
	Fuse aM	[A]	16	16	~
<b>Switching DC</b>					
Non-inductive or slightly inductive loads, resistance furnaces DC-1 at 60°C					
1 pole	24...48V	[A]	6 / 4	~	~
	110V	[A]	0.6	~	~
	220V	[A]	0.2	~	~
	440V	[A]	0.08	~	~
2 poles in series	24...48V	[A]	6	~	~
	110V	[A]	4	~	~
	220V	[A]	0.8	~	~
	440V	[A]	0.2	~	~
3 poles in series	24...48V	[A]	6	~	~
	110V	[A]	6	~	~
	220V	[A]	3	~	~
	440V	[A]	0.4	~	~
<b>Ratings according to UL/CSA</b>					
Operating voltage	AC	[V]	115	115	~
	AC	[V]	200	200	~
	AC	[V]	230	230	~
	AC	[V]	460	~	~
	AC	[V]	575	~	~
Cont. Rating (general purpose)	300V	[V]	12	10	~
	600V	[V]	12	10	~

#### Technical Information

##### CS4 / CS4-B Relays

##### Mechanical

<b>Mechanical Life</b>	[Mil]	10
------------------------	-------	----

##### Electrical Life

AC-15 (240V, 3A) AC Operations	[Mil]	~
AC-1 (230V, 6A)	[Mil]	0.7

<b>Weight</b>	[g]	153
---------------	-----	-----

##### Terminal Cross-Sections

##### Terminal Type



	1 Conductor	[mm <sup>2</sup> ]	0.75...2.5
	2 Conductor	[mm <sup>2</sup> ]	0.75...2.5
	1 Conductor	[mm <sup>2</sup> ]	0.75...2.5
	2 Conductor	[mm <sup>2</sup> ]	0.75...2.5

<b>Max. Wire Size</b>	[AWG]	18...14
-----------------------	-------	---------

<b>Tightening Torque</b>	[Nm]	1...1.5
--------------------------	------	---------

	[lb-in]	7...15
--	---------	--------

##### Control Circuit

##### Operating Voltage

AC 50/60 Hz	Pickup	[x U]	0.85...1.1
	Dropout	[x U <sup>S</sup> ]	0.35...0.65
DC	Pickup	[x U <sup>S</sup> ]	0.8...1.1
	Dropout	[x U <sup>S</sup> ]	0.1...0.25
with protection circuit	Dropout	[U <sub>max</sub> /U <sub>min</sub> ] <sup>S</sup>	1...1.2

##### Coil Consumption

AC 50/60 Hz	Inrush	[VA/W]	22 / 20
	Seal	[VA/W]	4 / 1.4
DC	Inrush/Seal	[W]	2.5

##### Operating Times

AC- 50/60 Hz	Pickup Time	[ms]	15...40
	Dropout Time	[ms]	15...25
DC	Pickup Time	[ms]	18...40
	Dropout Time	[ms]	6...12
with protection circuit	Dropout	[ms]	8...12

##### General

##### Rated Voltage Withstand U

IEC	500V
UL; CSA	600V
High voltage - 1 minute (per IEC 947-4)	2500V

<b>Rated Impulse Strength U<sub>imp</sub></b>	8 kV
---	------

##### Rated Voltage U<sub>e</sub>

AC	230, 240, 400, 415, 500V
DC	24, 48, 110, 220, 440V

<b>Rated Frequency</b>	50/60 Hz, DC
------------------------	--------------

##### Ambient Temperature

Storage	-55...+80°C (-67...176°F)
Operation at nominal current	-25...+60°C (-13...140°F)
At 85% rated operation current	-25...+70°C (-13... 158°F)

<b>Resistance to Climatic Change</b>	40° C (104° F), 95% relative humidity, 56 days
	23° C (73.4 ° F), 83%/40 ° C (104 ° F), 93%, 56 cycles

<b>Altitude</b>	2000m M.S.L., per IEC 947-4
-----------------	-----------------------------

##### Type of Protection

IP 20 (IEC 529 and DIN 40050)	in connected state
-------------------------------	--------------------

##### Finger Protection

safe from touch by fingers and back of hand per VDE 0106, Part 100

##### CRZE4/CRZY4 Electronic Timers

##### Permissible voltage

CRZE4 (AC or DC)	110V (-23%) - 250V (+10%)
CRZY4 (AC only)	110V (-23%) - 120V (+10%)
	220V (-20%) - 250V (+10%)

<b>Voltage drop</b>	5V max
---------------------	--------

<b>Load current for reliable operation</b>	10mA min
--	----------

##### Load current

20°C (68° F)	600mA
40°C (104° F)	440mA
55°C (131° F)	320mA

##### Leakage current at 220V

CRZE4	5mA
CRZY4	"Y" 17mA, "Δ" 6mA

<b>Reset time</b>	≥200ms
-------------------	--------

##### Voltage failure duration having no influence on timing sequence

CRZE4	15ms
CRZY4	≥20ms

##### Repeat accuracy

At fixed temperature	±1%
With temperature range of 5...+55°C (+23...+131° F)	±5%

##### Time interval for start commands

CRZE4	1.4 x set time
CRZY4	2 x set time

##### Ambient temperature

Storage	-40°C to +80°C (-40...+176° F)
Operation	-20°C to +55°C (-4...+131° F)

##### Terminals: 0.8 mm<sup>2</sup> (AWG 18)

CRZE4	2 free cable ends, each 250 mm long
CRZY4	4 free cable ends, each 250 mm long

**Series CS4 & CS4-B Industrial Control Relays**

- Dimensions are in millimeters (inches)
- Dimensions not intended for manufacturing purposes

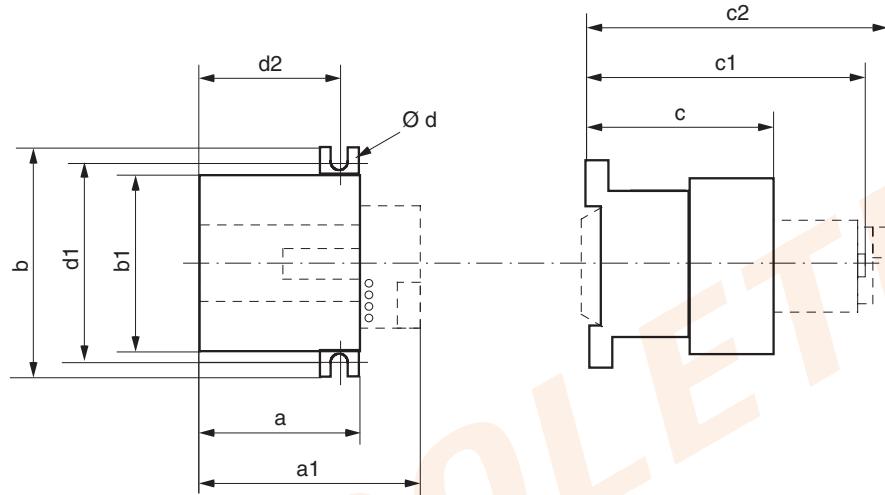

Type	a	a1	b	b1	c	c1	c2	$\varnothing d$	d1	d2
CS4(B) (AC & DC)	45 (1-25/32)	67 (2-21/32)	56 (2-3/16)	47 (1-14/16)	48 (1-29/32)	74 (2-15/16)	77 (3-1/16)	4.2 (11/64)	50 (1-31/32)	40 (1-9/16)

**Relays & Accessories**

Relay with...		Dim. [mm]	Dim. [inches]
with aux. contact block		c1	c1
with timer	on relay	c2	c2
	at side of relay	a1	a1
with neutral terminal	at side of relay	a+20	a + 1-25/32
with protection element		c2	c2
with nameplate		c..+5	c..+ 3/16

**Mounting Position**

