

1. DIMENSIONS AND PARTS LIST

<DIMENSIONS>

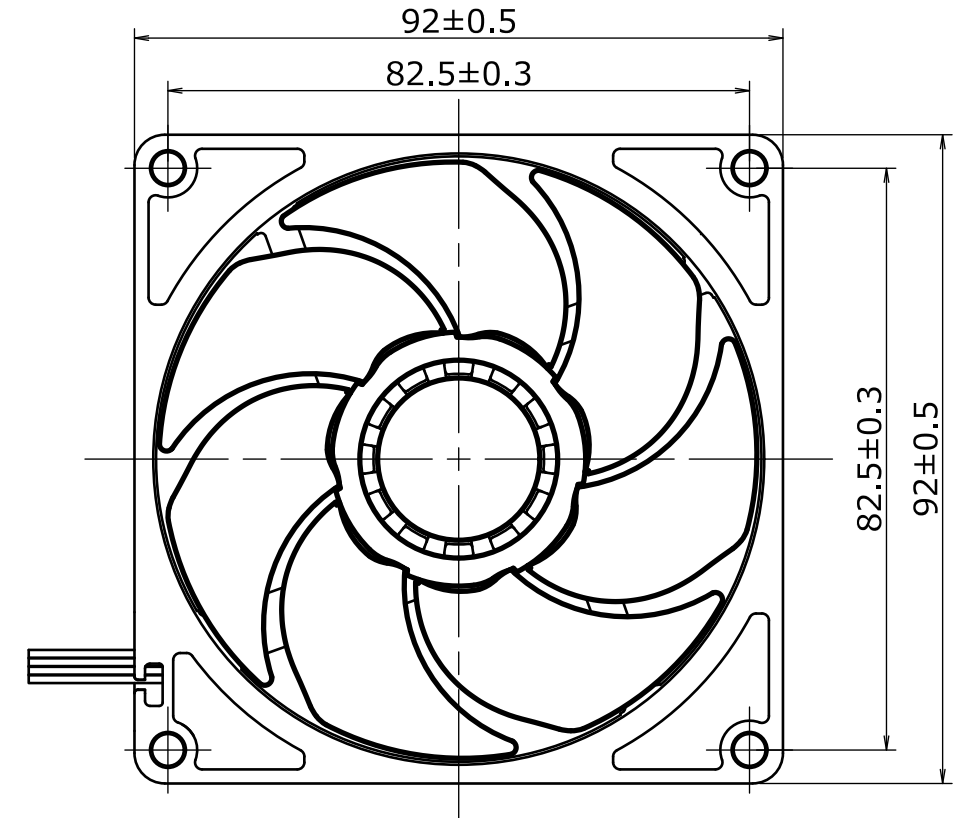
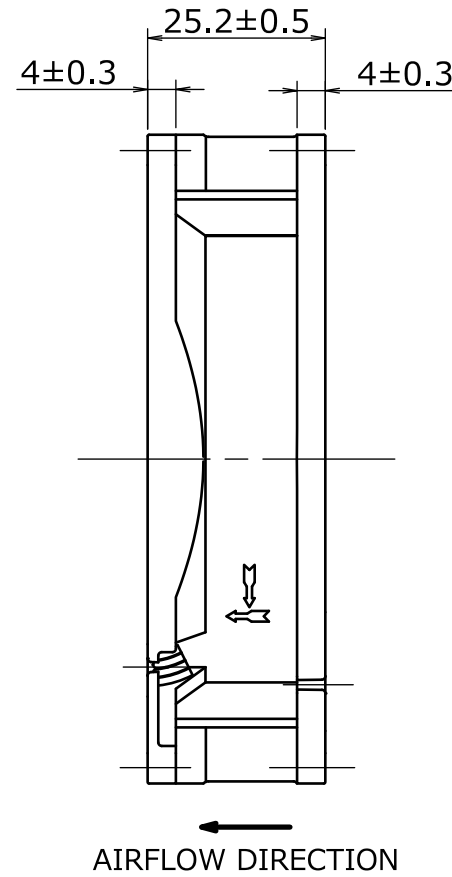
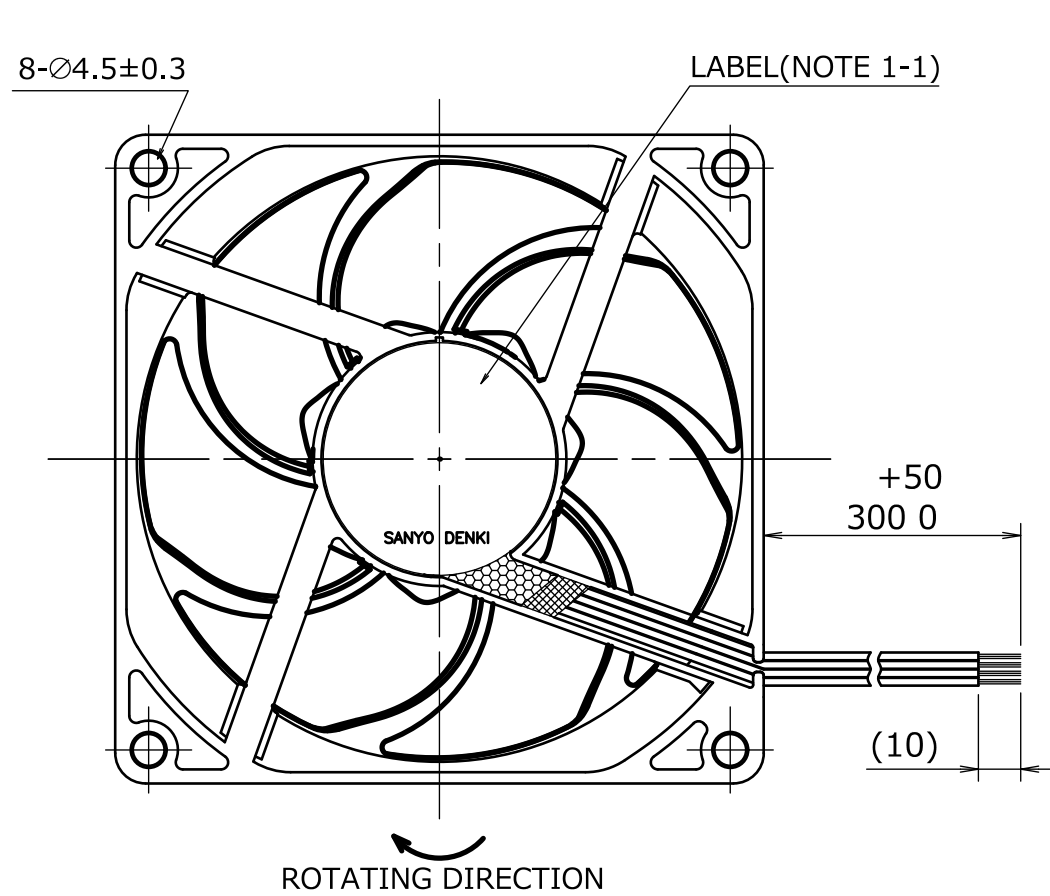

NOTE 1-1. PRINT PRODUCT NAME, MODEL No., MANUFACTURER, AND MANUFACTURED DATE ETC.

品名, 型名, 製造会社名 及び 製造年月日等を表示する。

1-2. ALL ELECTRICAL PARTS IN THIS FAN MOTOR HAVE BEEN COATED WITH A LAYER OF RESIN.

本ファンモータは、活電部に樹脂コーティングを施しています。

<LEAD WIRE CONNECTION TABLE>

FAN		
SIGNAL	LEAD WIRE	COLOR
+	UL1430 AWG26	RED
GND	UL1430 AWG26	BLACK
PWM	UL1430 AWG26	BROWN
SENSOR	UL1430 AWG26	YELLOW

	ECN No.	名称 Title	
	E0204681	San Ace 92W (9WPA)	
単位 Unit	新規 New Design	RIBLESS/PULSE_SENSOR/PWM_CONTROL	
mm	C.KURASHIMA 20-10-30		
尺度 Scale	図面番号 Dwg. No.	9WPA0924P4G2011	
-		Rev. B	
SANYO DENKI		承認 Approved By	設計 Designed By
		TE.YAMAZAKI	M.AUTIDA
		20-11-14	20-11-13
Group	D12	審査 Checked By	Page
		A.NAKAYAMA	E0
		20-11-14	1/4

2. DESCRIPTION AND AIRFLOW-STATIC PRESSURE CHARACTERISTICS EXAMPLE

<DESCRIPTION>

ITEM	UNIT	DESCRIPTION		
PWM DUTY CYCLE	%	100	20	0
RATED VOLTAGE	V DC	24		
OPERATING VOLTAGE RANGE	V DC	21.6 ~ 26.4		
MAX. AIRFLOW (NOTE 2-2)	m ³ /min (CFM)	2.45 (86.5)	0.52 (18.4)	- -
MAX. STATIC PRESSURE (NOTE 2-2)	Pa (inchH ₂ O)	126 (0.51)	6 (0.02)	- -
RATED CURRENT (NOTE 2-2)	A	0.25	0.03	0.03 MAX.
RATED SPEED	min ⁻¹	5700±570	1200±360	NO ROTATION
INSULATION RESISTANCE (NOTE 2-3)	-	10 MΩ MIN. AT 500 V DC		
DIELECTRIC STRENGTH (NOTE 2-3)	-	1 MINUTE AT 500 V AC, 50/60 Hz		
OPERATING TEMPERATURE	℃	-40 ~ 70		
STORAGE TEMPERATURE	℃	-40 ~ 70		
EXPECTED LIFE	-	40,000 h / 60 °C (L10, CONTINUOUS OPERATION)		
SOUND PRESSURE LEVEL (NOTE 2-2, 2-4)	dB(A)	47	11	-
MASS	g	APPROX. 135		
MATERIAL	-	FRAME, IMPELLER : PLASTICS		
BEARING SYSTEM	-	2 BALL BEARINGS		
CONTROL TERMINAL	-	SOURCE CURRENT: 1 mA MAX. AT CONTROL VOLTAGE 0 V		
	-	SINK CURRENT : 1 mA MAX. AT CONTROL VOLTAGE 5.25 V		
	-	CONTROL TERMINAL VOLTAGE : 5.25 V MAX. (OPEN CIRCUIT)		
IP CODE	-	IP68 (IEC 60529:2001)		

<AIRFLOW-STATIC PRESSURE CHARACTERISTICS EXAMPLE>

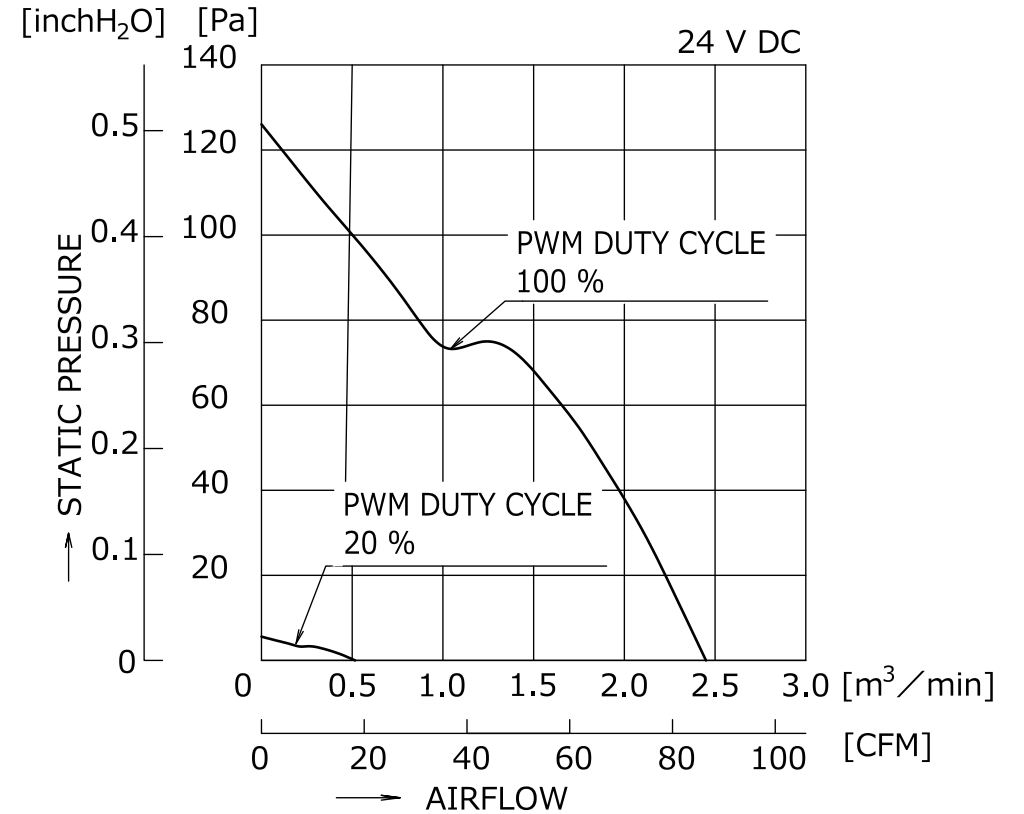

- NOTE 2-1. VALUES FOR EACH CHARACTERISTIC ARE AT ROOM TEMPERATURE AND NORMAL HUMIDITY.
諸特性は常温、常湿での値。
- 2-2. UNSPECIFIED VALUE IS THE NOMINAL VALUE.
指定なき値は標準値。
- 2-3. MEASURED BETWEEN LEAD WIRE CONDUCTORS AND FRAME.
リード線導体部とフレームとの間。
- 2-4. MEASURED AT 1 m FROM THE AIR INLET.
ファン吸込側より1 mにて測定する。
- 2-5. MOTOR IS PROTECTED FROM DAMAGE OF LOCKED ROTOR CONDITION AT THE OPERATING VOLTAGE.
DO NOT LOCK ROTOR OUTSIDE OF OPERATING VOLTAGE.
ファン拘束時焼損の恐れはない。使用電圧範囲外でファンを拘束しないこと。

	ECN No.	E0204681	名称 Title	San Ace 92W (9WPA)	
	単位 Unit	新規 New Design	C.KURASHIMA	RIBLESS/PULSE_SENSOR/PWM_CONTROL	
mm	20-10-30				
尺度 Scale	図面番号 Dwg. No.	9WPA0924P4G2011			Rev. B
SANYO DENKI		承認 Approved By	審査 Checked By	設計 Designed By	
SANYO DENKI CO.,LTD. ISSUED		TE.YAMAZAKI	A.NAKAYAMA	M.AUTIDA	
Group		20-11-14	20-11-14	20-11-13	
D12		User	E0	Page 2/4	

3. SENSOR SPECIFICATIONS

<OUTPUT CIRCUIT>

OPEN COLLECTOR

<SPECIFICATIONS>

$V_{CE} = +26.4 \text{ V DC MAX.}$

$I_C = 5 \text{ mA MAX. (} V_{CE} \text{ (SAT)} = 0.6 \text{ V MAX.)}$

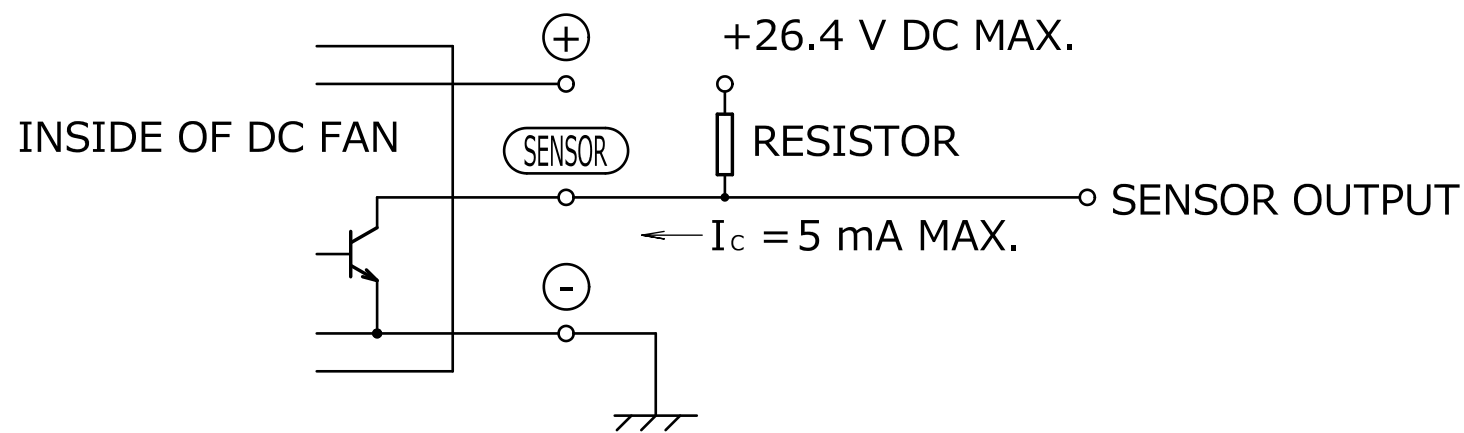

<OUTPUT WAVEFORM>

(a) IN CASE OF STEADY RUNNING

ONE REVOLUTION

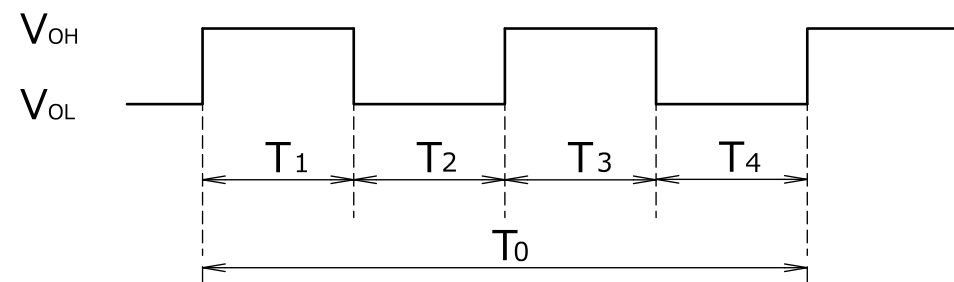

$$T_{1 \text{ to } 4} \cong (1/4) T_0$$

$$T_{1 \text{ to } 4} \cong (1/4) T_0 = 60/4 \text{ N (s)}$$

$$N = \text{FAN SPEED (min}^{-1}\text{)}$$

(b) IN CASE OF STEADY LOCKED ROTOR

SENSOR OUTPUT IS FIXED EITHER (b-1) OR (b-2).
センサー出力は(b-1)あるいは(b-2)のどちらかに固定される。

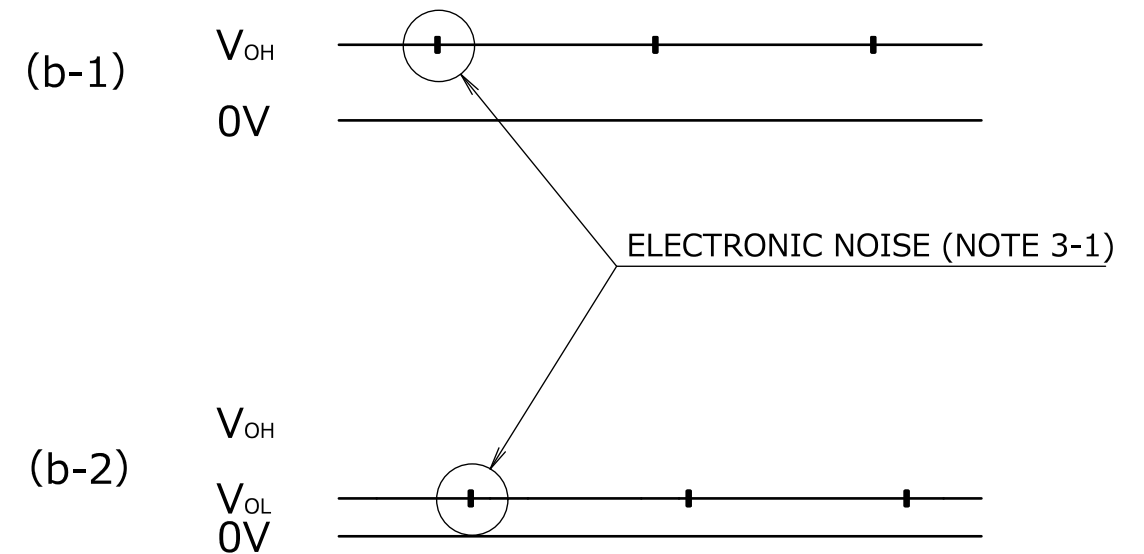

NOTE: 3-1. THE ELECTRONIC NOISE DUE TO AUTO-RESTART BEHAVIOR OF THE MOTOR MAY INFLUENCE V_{OH} OR V_{OL} .
モータの再起動動作にともない、 V_{OH} あるいは V_{OL} にノイズが載ることがある。

	ECN No.	名称 Title		
	E0204681	San Ace 92W (9WPA) RIBLESS/PULSE_SENSOR/PWM_CONTROL		
単位 Unit	新規 New Design	設計 Designed By		
mm	C.KURASHIMA 20-10-30	承認 Approved By	審査 Checked By	設計 Designed By
尺度 Scale	図面番号 Dwg. No.	TE.YAMAZAKI 20-11-14	A.NAKAYAMA 20-11-14	M.AUTIDA 20-11-13
-	-	9WPA0924P4G2011		Rev. B
		承認 Approved By	審査 Checked By	設計 Designed By
		TE.YAMAZAKI 20-11-14	A.NAKAYAMA 20-11-14	M.AUTIDA 20-11-13
Group	D12	User	E0	Page 3/4

4. PWM DUTY-SPEED CHARACTERISTICS EXAMPLE

<PWM DUTY-SPEED CHARACTERISTICS EXAMPLE>

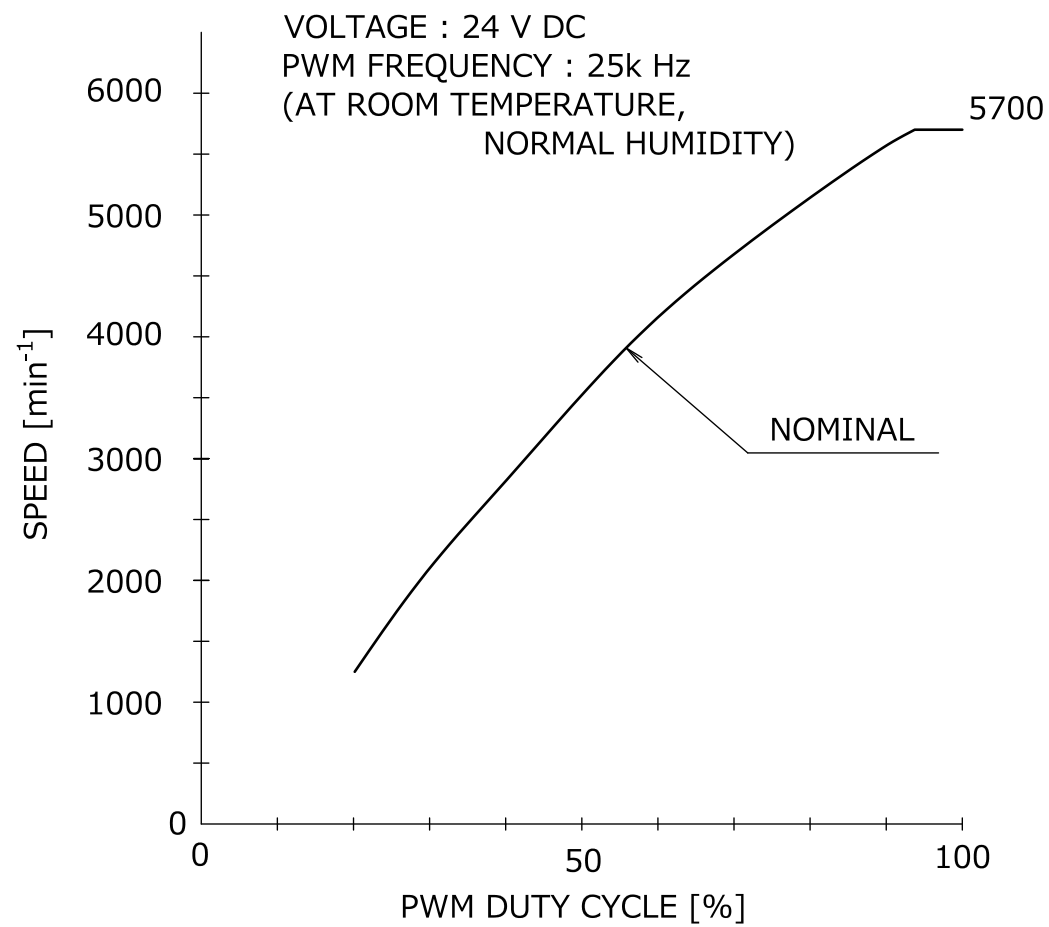

<EXAMPLE OF CONNECTION SCHEMATIC>

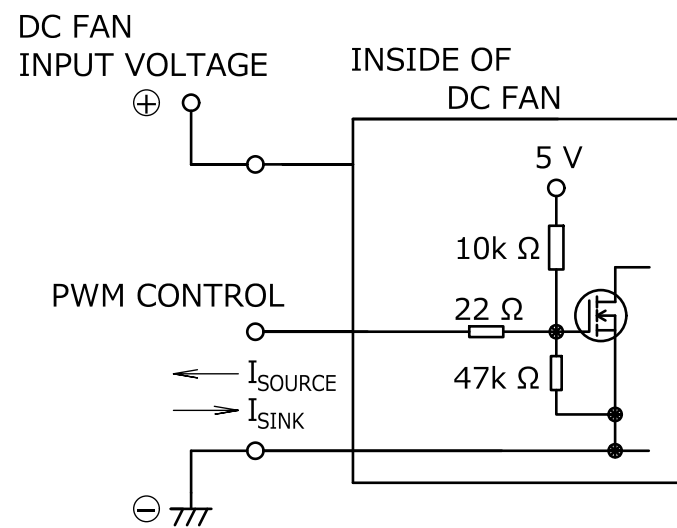

<PWM INPUT SIGNAL EXAMPLE>

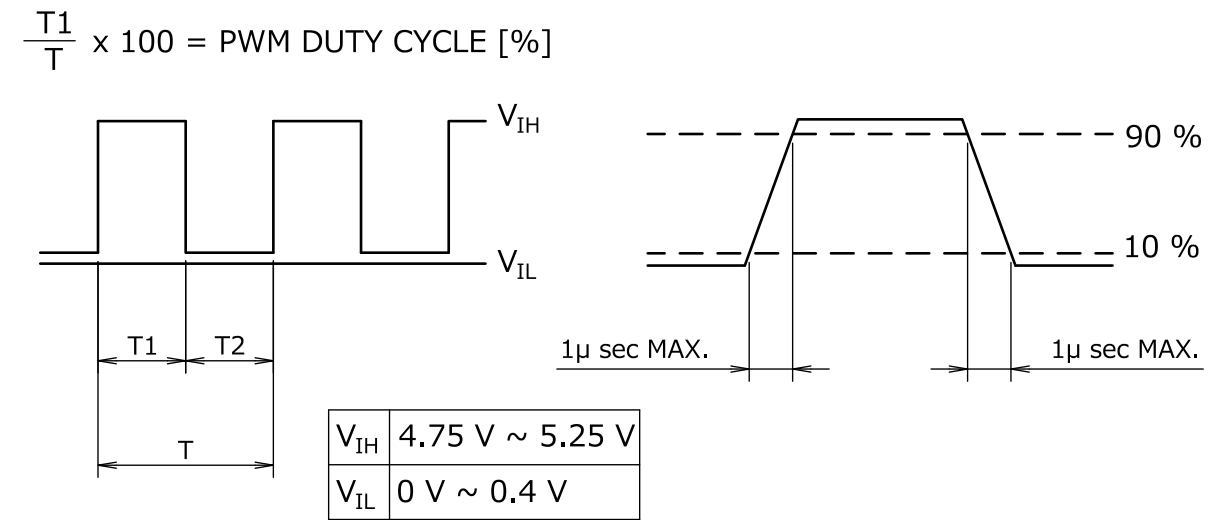

- NOTE 4-1. PWM CONTROL SWITCHING MAY AFFECT THE SENSOR OUTPUT.
 PWM制御によるスイッチングがセンサ出力に影響する場合があります。
- 4-2. REFER TO PAGE 2 FOR THE SPEED WITH PWM DUTY CYCLE OF 0, 20, 100 %.
 PWMデューティサイクルが 0, 20, 100 %の時、回転速度は2頁を参照のこと。
- 4-3. WHEN THE CONTROL TERMINAL IS OPEN,
 FAN SPEED IS THE SAME AS WHEN PWM DUTY CYCLE IS 100 %.
 PWM入力端子がオープン状態の時、回転速度はPWMデューティサイクル100 %と同じである。
- 4-4. EITHER TTL INPUT, OPEN COLLECTOR OR OPEN DRAIN CAN BE USED
 FOR PWM CONTROL INPUT SIGNAL.
 AND IN CASE OF OPEN COLLECTOR, DRAIN INPUT,
 THE PWM DUTY CYCLE SHOULD BE $(T-T2) \times 100 / T$.
 PWM入力信号はTTL入力又は、オープンコレクタ、ドレイン入力にて使用可能である。
 但し、オープンコレクタ、ドレイン入力の場合、PWMデューティ = $(T-T2) \times 100 / T$ である。

	ECN No. E0204681	名称 Title San Ace 92W (9WPA)
	単位 Unit mm	新規 New Design C.KURASHIMA 20-10-30
尺度 Scale -	図面番号 Dwg. No.	9WPA0924P4G2011
		承認 Approved By TE.YAMAZAKI 20-11-14
		審査 Checked By A.NAKAYAMA 20-11-14
		設計 Designed By M.AUTIDA 20-11-13
Group	D12	User E0 Page 4/4