

Metal Element Current Sense Resistor



ULR Series

Features

- Robust metal strip able to withstand high temperature and high current.
- Power ratings up to 5W
- Low TCR and Inductance
- Resistance Range from 0.15mΩ to 10mΩ
- RoHS compliant
- AEC-Q200
- Higher wattage devices feature PCB clearance gap to maximize thermal performance



All parts are Pb-free and comply with EU Directive 2011/65/EU amended by (EU) 2015/863 (RoHS3)

Electrical Data

| Type | Size | Coating | Power Rating ^{3(W)} | Standard Resistance Value mΩ ¹ | TCR (ppm/°C) | Tolerance (%) | Dielectric Withstanding Voltage (V) | Ambient Temperature (°C) |
|--------------------------------|------|-----------------|------------------------------|---|--------------|---------------|-------------------------------------|--------------------------|
| ULRG1 / ULR1S | 1206 | Green Underside | 1 | 0.2, 0.25, 0.3, 0.4, 0.5, 0.6 | 200 | 1, 5 | N/A | -55 to +170 |
| ULRG15 / ULR15S | 2010 | | | 0.75, 1, 1.2, 2, 2.5, 3, 3.5, 4, 5, 5.5, 6, 7, 8, 9, 10 | 50 | | | |
| ULR2N | 1020 | | 2 | 0.2, 0.25, 0.3, 0.4, 0.5 | 150 | | | |
| | | | | 0.75, 1, 1.5, 2, 2.5, 3, 4, 5, 5.5, 6, 7, 8, 9, 10 | 50 | | | |
| ULRG2 / ULR2 ULRG25 / ULR25 | 2512 | | 2 | 1 | 300 | | | |
| | | | | 1.5, 2, 2.5, 3 | 170 | | | |
| | | | 2.5 | 6.5, 7, 7.5, 8, 9, 10 | 50 | | | |
| | | | | 3.5, 4, 4.5, 5, 5.5, 6 | | | | |
| ULRG3 / ULR3 | 2512 | | 3 | 0.15, 0.25, 0.3, 0.4, 0.5, 0.75 | 150 | | | |
| | | | | 1, 1.5, 2, 2.5, 3 | 50 | | | |
| ULR5 | 2512 | 5 ² | 0.5, 0.75 | 150 | | | | |
| | | | 1, 1.5, 2, 2.5, 3 | 50 | | | | |
| ULR3N | 1225 | 3 | 0.1 | 500 | | | | |
| | | | 0.2, 0.25, 0.3, 0.4 | 350 | | | | |
| | | | 0.5 | 300 | | | | |
| | | | 0.7, 0.75, 0.8, 0.9, 1.0 | 250 | | | | |
| | | | 1.5, 2.0, 2.5, 3.0 | 100 | | | | |
| ULRB1 / ULR1 | 2512 | Black | 1 | 0.5, 0.75, 1, 1.5, 2 | 50 | | | |
| | | | | 2.5, 3, 3.5 | 150 | | | |
| | | | | 1, 5, 10 | 100 | | | |
| ULRB2 / ULR2 | 2512 | Black | 2 | 6, 6.5, 7 | 75 | | | |
| | | | | 0.5, 0.75, 1, 1.5, 2 | 50 | | | |
| | | | | 2.5, 3 | 150 | | | |

Notes: 1. For higher resistance values please refer to LRMA series.

Notes: 2. Terminal temp must not exceed 110°C

Notes: 3. Green Underside parts are rated at 80°C. Black parts are rated at 70°C.

Performance Data

| AEC-Q200 Table 7 | | Method | | Max. (add R0005) | | |
|------------------|--|------------------------|-----|------------------|-------------------|--|
| ref. | Test ¹ | | | Black | Green Underside | |
| | | | | 1206 & 2010 | 1020, 2512 & 1225 | |
| 3 | High Temp. Exposure * | MIL-STD-202 Method 108 | ΔR% | 1 | | |
| 4 | Temperature Cycling | JESD22 Method JA-104 | ΔR% | 0.5 | 1 | |
| 6 | Moisture Resistance | MIL-STD-202 Method 106 | ΔR% | 1 | | |
| 7 | Biased Humidity | MIL-STD-202 Method 103 | ΔR% | 1 | | |
| 8 | Operational Life (Cyclic Load) * | MIL-STD-202 Method 108 | ΔR% | 1 | | |
| 14 | Vibration | MIL-STD-202 Method 204 | ΔR% | 0.5 | 1 | |
| 15 | Resistance to Soldering Heat * | MIL-STD-202 Method 210 | ΔR% | 0.5 | 1 | |
| 16 | Thermal Shock * | MIL-STD-202 Method 107 | ΔR% | 0.5 | 1 | |
| 18 | Solderability | J-STD-002 | | >95% coverage | | |
| 21 | Board Flex | AEC-Q200-005 | ΔR% | 0.5 | 1 | |
| 22 | Terminal Strength | AEC-Q200-006 | ΔR% | 0.25 | 1 | |
| | Short Term Overload * | 5 x Pr for 5s | ΔR% | 0.5 | 1 | |
| | Resistance to Sulphur-Bearing Gas ² | EIA-977 | ΔR% | N/A | 1 | |

Notes: 1. Full AEC-Q200 qualification applies to 2512 size. The 1206 and 2010 sizes have received the tests marked *.

2. Resistance to sulphur bearing gas has been tested for green underside construction only.

General Note

TT Electronics reserves the right to make changes in product specification without notice or liability.

All information is subject to TT Electronics' own data and is considered accurate at time of going to print.

BI Technologies IRC Welwyn

www.ttelectronics.com/resistors

ULR Series

Physical Data

| Dimensions(mm) and weight (mg) | | | | | | | |
|--------------------------------|---------------------------|---------------------------|--------------|------------|------------|------------|----------|
| Size | Coating | Values | L (±0.25) | W | T (±0.2) | D | Wt (nom) |
| 1206 | Green Underside | 0.2, 0.25 | 3.2 | 1.6 ±0.3 | 1.0 | 1.5 ±0.25 | 25 |
| | | 0.3, 0.4 | | | | 1.4 ±0.25 | |
| | | 0.5, 0.6 | | 1.6 ±0.1 | 0.6 | 1.35 ±0.25 | 20 |
| | | 0.75 | | | | 1.23 ±0.25 | |
| | | 1, 1.2, 3.5, 4, 5, 5.5, 6 | | | | 1.1 ±0.25 | |
| | | 2, 2.5, 3, 10 | | | | 0.6 ±0.25 | |
| | | 7, 8, 9 | | | | 0.9 ±0.25 | |
| 2010 | | 0.2 | 2.54 ±0.3 | 1.0 | 2.34 ±0.25 | 50 | |
| | | 0.25 | | | 2.24 ±0.25 | | |
| | | 0.3 | | | 2.04 ±0.25 | | |
| | | 0.4 | | | 1.84 ±0.25 | | |
| | | 0.5 | 2.54 ±0.15 | 0.6 | 2.17 ±0.25 | 40 | |
| | | 0.75 | | | 2.04 ±0.25 | | |
| | | 1, 1.5, 4, 5, 5.5 | | | 1.84 ±0.25 | | |
| 1020 | 2, 2.5, 6, 7, 8 | 5.08 | 1.0 | 1.54 ±0.25 | 59 | | |
| | 3 | | | 1.04 ±0.25 | | | |
| | 9, 10 | | | 1.29 ±0.25 | | | |
| | 1, 1.5, 2, 2.5, 3 | | | 2.54 | | 5.08±0.25 | 0.6 |
| 2512 | 0.15 | 6.35 | 3.0 ±0.3 | 1.0 | 2.98 ±0.25 | 59 | |
| | 0.2 | | | | 2.88 ±0.25 | | |
| | 0.25, 0.3 | | | | 2.68 ±0.25 | | |
| | 0.4 | | | | 2.18 ±0.25 | | |
| | 0.5 | | | | 2.68 ±0.25 | | |
| | 0.75 | 3.0 ±0.2 | 0.6 | 2.48 ±0.25 | 65 | | |
| | 1, 5, 5.5, 6 | | | 1.93 ±0.25 | | | |
| | 2, 2.5, 3, 3.5, 8, 9, 10 | | | 1.18 ±0.25 | | | |
| | 4, 4.5 | | | 2.18 ±0.25 | | | |
| | 1.5, 6.5, 7, 7.5 | | | 1.43 ±0.25 | | | |
| 1225 | 0.1, 0.2, | 3.0 | 6.35±0.25 | 1 | 1.0±0.25 | 65 | |
| | 0.25, 0.3, 0.4 | | | 1 | 0.5±0.25 | | |
| | 0.5, 0.7, 0.75, 0.8, 0.9, | | | 0.6 | 0.5±0.25 | | |
| | 1.0 | | | 0.6 | 1.0±0.25 | | |
| | 1.5 | | | 0.6 | 0.8±0.25 | | |
| | 2 | | | 0.6 | 0.5±0.25 | | |
| 2512 | Black | 0.5 | 6.35 | 3.18 ±0.25 | 1.25 | 1.85 ±0.38 | 184 |
| | | 0.75 | | | 0.75 | | 131 |
| | | 1 | | | 0.65 | 111 | |
| | | 1.5 | | | 0.45 | 69 | |
| | | 2 | | | 0.35 | 49 | |
| | | 2.5 | | | 0.65 | 98 | |
| | | 3 | | | 0.55 | 83 | |
| | | 4 | | | 0.45 | 63 | |
| | | 5 | | | 0.35 | 50 | |
| | | 6 | | | 0.32 | 42 | |
| | | 6.5 | | | 0.3 | 36 | |
| | | 7 | | | 0.27 | 34 | |
| | | 10 | | | 0.25 | 26 | |

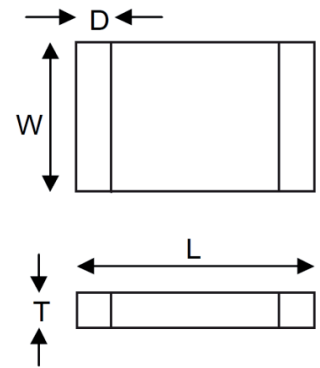

General Note

TT Electronics reserves the right to make changes in product specification without notice or liability.
All information is subject to TT Electronics' own data and is considered accurate at time of going to print.

ULR Series

Construction

Black Coat

A low TCR resistance alloy plate, with tin plated connection bands is protectively coated on the upper and lower faces and numerically marked with the resistance value. This part is suitable for wave or reflow soldering.

Green Underside Coat

A low TCR resistance alloy plate is grooved to set the final resistance and the lower face only is protected with an epoxy coating. The lower faces are tin plated for connections. This part is ONLY suitable for reflow soldering.

Marking

Only black coated parts are marked. For values which are integer numbers of milliohms, the marking is 4-character IEC62 code; e.g. "R002" for 2mΩ, "R010" for 10mΩ. For values including fractions of a milliohm the marking is 3 or 4-character code using "M" to indicate the decimal point, e.g. "M75" for 0.75mΩ, "1M50" for 1.5mΩ.

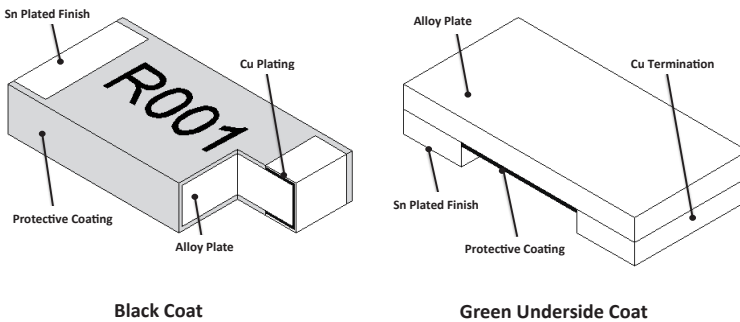

Termination Details:

Material

Matt tin plated finish over copper.

Solderability

95% min coverage (MIL-STD 202F / 208H, 245°C for 3 secs)

Power Derating Curves

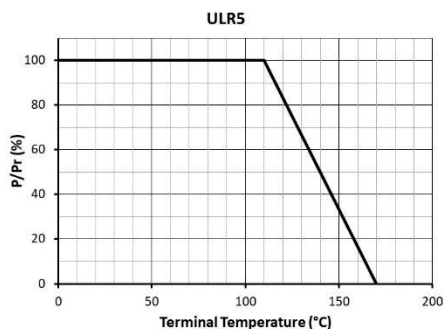
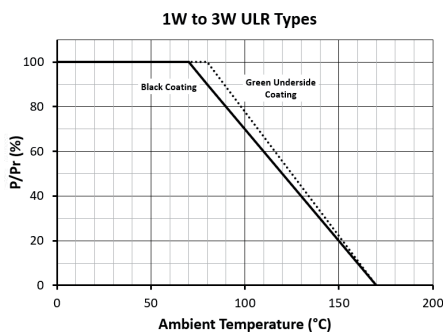

Notes

The power derating curve is a guidance based on a conservative design model. The ULR is a solid metal alloy construction that can withstand significantly greater operating temperatures than the conservative model permits. The protective coating will operate up to 260°C and the alloy can withstand in excess of 350°C. Therefore, the system thermal design will be a more significant design parameter due to the heat limitations of the solder joint.

Full power dissipation is achievable with the part mounted on 120x51mm high-Tg FR4 board with 70µm inner and outer planes. Alternative mounting arrangements may be used, provided the heatsinking effect permits a combination of power dissipation and terminal temperature within the derating curve shown.

General Note

TT Electronics reserves the right to make changes in product specification without notice or liability. All information is subject to TT Electronics' own data and is considered accurate at time of going to print.

ULR Series

Recommended Layouts and Measurement Probe Positions

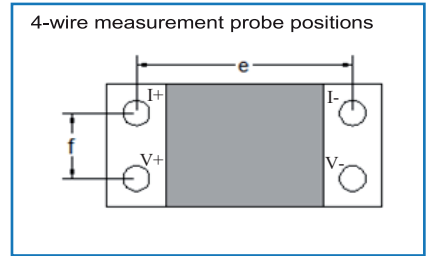
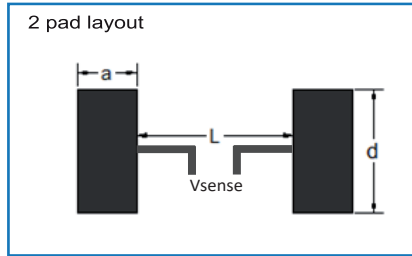
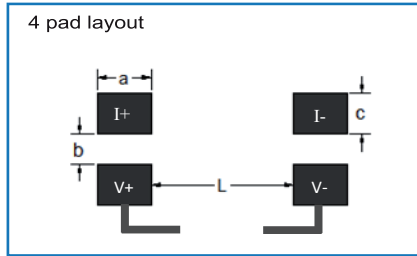

| Size | Coating | Values | a | b | c | L | d | e | f | | | | |
|------|-----------------|--------------------|--------|------|------|------|------|------|------|------|------|-----|-----|
| 1206 | Green Underside | 0.5, 0.6, 1, 4 - 6 | 1.55 | 0.5 | 0.7 | 0.55 | 1.9 | 2.6 | 1.25 | | | | |
| | | 2 - 3, 10 | 1.05 | | | 1.55 | | | | | | | |
| | | 7 - 9 | 1.35 | | | 0.95 | | | | | | | |
| 2010 | | 0.5 | 2.61 | 0.8 | 1.05 | 0.3 | 2.9 | 4.32 | 1.2 | | | | |
| | | 1, 4 - 5 | 2.29 | | | 0.95 | | | | | | | |
| | | 2, 6 - 8 | 1.99 | | | 1.55 | | | | | | | |
| | | 3 | 1.49 | | | 2.55 | | | | | | | |
| 1020 | | | 9 - 10 | 1.74 | | | 2.05 | | | | | | |
| 2512 | | Black | All | 2.7 | 1.0 | 1.2 | 1.04 | 5.53 | 2 | 1.77 | | | |
| 2512 | | Green Underside | 0.5 | 3.13 | | | 2.95 | | | | 3.45 | 3.6 | 5.4 |
| | 0.75 | | 2.93 | 0.54 | | | | | | | | | |
| | 1 | | 2.38 | 0.94 | | | | | | | | | |
| | 1.5 | | 1.88 | 2.04 | | | | | | | | | |
| | 2 - 3 | | 1.63 | 3.04 | | | | | | | | | |
| | 4, 4.5 | | 2.63 | 3.54 | | | | | | | | | |
| | 5 - 6 | | 2.38 | 1.54 | | | | | | | | | |
| | 6.5, 7 | | 1.88 | 2.04 | | | | | | | | | |
| | 8 - 10 | | 1.63 | 3.04 | | | | | | | | | |
| | 3.54 | | | | | | | | | | | | |
| 1225 | | 0.1 - 0.25 | 1.4 | 0.8 | 3.0 | 0.6 | 6.8 | 2.0 | 2.25 | | | | |
| | | 0.3 - 1.0 | 0.9 | | | 1.6 | | | | | | | |
| | | 1.5 | 1.4 | | | 0.6 | | | | | | | |
| | | 2.0 | 1.2 | | | 1.0 | | | | | | | |
| | | 2.5, 3.0 | 0.9 | | | 1.6 | | | | | | | |

Note: These resistors are designed to have the correct ohmic value when mounted on a PCB. Probed measurements may read higher values and mounting offsets may need to be established to account for this, especially with sub-milliohm values.

Symmetrical Kelvin Connected (4-Wire) Alternatives

| Package | Resistance (mΩ) | a | b | c | d | e | f |
|------------------------|-----------------|------|------|-----|-----|------|-----|
| 1206 | 0.2 - 0.4 | 0.75 | 1.9 | 0.4 | 0.6 | 2.15 | 0.6 |
| 2010 | 0.2 - 0.4 | 1.35 | 2.89 | 1.4 | 0.6 | 3.08 | 0.6 |
| 2512 - Green Underside | 0.15 - 0.3 | 2 | 3.4 | 1.0 | 0.6 | 2.8 | 0.6 |
| | 0.4 | 1.5 | 3.4 | 2.0 | 0.6 | 3.8 | 0.6 |

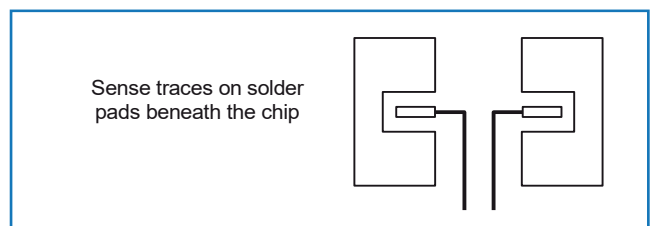
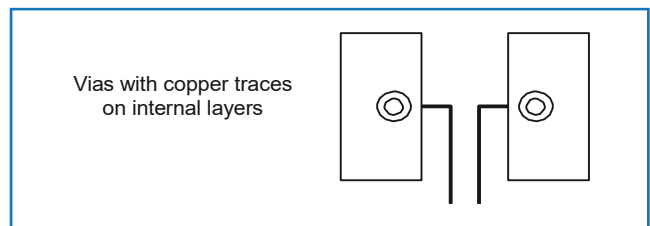
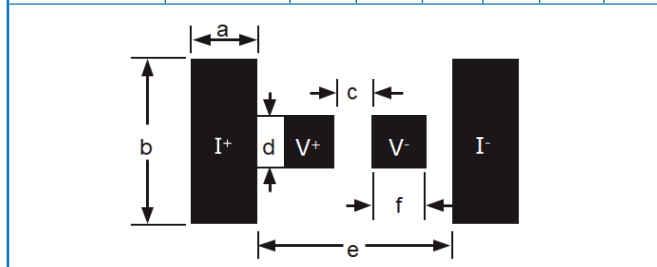

General Note

TT Electronics reserves the right to make changes in product specification without notice or liability. All information is subject to TT Electronics' own data and is considered accurate at time of going to print.

ULR Series

Packaging

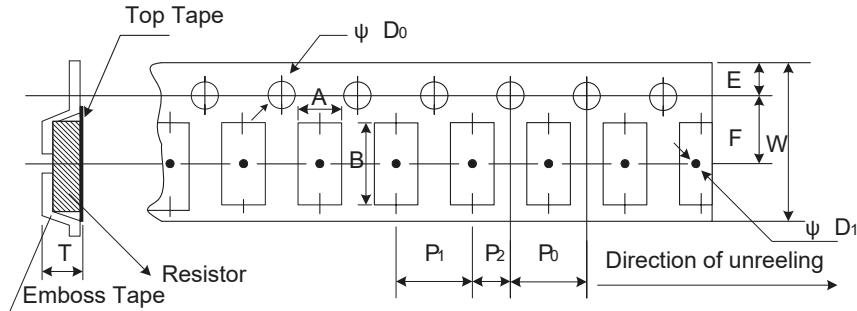

| Type | Resistance (mΩ) | A | B | W | E | F | P0 | P1 | P2 | ØD0 | ØD1 | T | Quantity (EA) |
|----------------------|-----------------|------------|------------|------------|------------|------------|-----------|-----------|------------|-------------|--------|------------|-----------------|
| 1206 | <0.5 | 1.90 ± 0.1 | 3.60 ± 0.1 | 8.0 ± 0.2 | 1.75 ± 0.1 | 3.5 ± 0.05 | 4.0 ± 0.1 | 4.0 ± 0.1 | 2.0 ± 0.05 | 1.55 ± 0.05 | 1.0min | 1.25 ± 0.1 | 2000 on 7" reel |
| | ≥0.5 | | | | | | | | | | | 0.87 ± 0.1 | |
| 2010 | <0.5 | 2.85 ± 0.1 | 5.55 ± 0.1 | 12.0 ± 0.2 | 1.75 ± 0.1 | 5.5 ± 0.05 | 4.0 ± 0.1 | 4.0 ± 0.1 | 2.0 ± 0.05 | 1.55 ± 0.05 | 1.5min | 1.35 ± 0.1 | |
| | ≥0.5 | | | | | | | | | | | 0.85 ± 0.1 | |
| 1020 | 1 - 3 | | | | | | | | | | | | |
| 2512 Black | 0.50 - 0.75 | 3.40 ± 0.1 | 6.75 ± 0.1 | 12.0 ± 0.1 | 1.75 ± 0.1 | 5.5 ± 0.05 | 4.0 ± 0.1 | 4.0 ± 0.1 | 2.0 ± 0.05 | 1.55 ± 0.05 | 1.4min | 1.45 ± 0.2 | |
| | >0.75 | | | | | | | | | | | 0.81 ± 0.1 | |
| 2512 Green Underside | <0.5 | 3.40 ± 0.1 | 6.75 ± 0.1 | 12.0 ± 0.3 | 1.75 ± 0.1 | 5.5 ± 0.05 | 4.0 ± 0.1 | 4.0 ± 0.1 | 2.0 ± 0.05 | 1.55 ± 0.05 | 1.5min | 1.4 ± 0.1 | |
| | ≥0.5 | | | | | | | | | | | 0.8 ± 0.1 | |
| 1225 | 0.1-0.4 | 3.40 ± 0.1 | 6.75 ± 0.1 | 12.0 ± 0.3 | 1.75 ± 0.1 | 5.5 ± 0.05 | 4.0 ± 0.1 | 4.0 ± 0.1 | 2.0 ± 0.05 | 1.55 ± 0.05 | 1.5min | 1.2 ± 0.1 | |
| | 0.5-3.0 | | | | | | | | | | | 0.80 ± 0.1 | |

Note:

1. The cumulative tolerance of 10 sprocket hole pitch is ± 0.2 mm.
2. Carrier camber shall not be more than 1 mm per 100 mm through a length of 250 mm.
3. A & B measured 0.3 mm from the bottom of the packet.
4. T measured at a point on the inside bottom of the packet to the top surface of the carrier.
5. Pocket position relative to sprocket hole is measured as the true position of the pocket and not the pocket hole.

General Note

TT Electronics reserves the right to make changes in product specification without notice or liability. All information is subject to TT Electronics' own data and is considered accurate at time of going to print.

ULR Series

Ordering Procedure

This product has two valid part numbers:

European (Welwyn) Part Number: ULR2-R0015FT2 (2512, 1.5 milliohms $\pm 1\%$, Pb-free)

| | | | | | | | | | | | | | |
|---|---|---|---|---|---|---|---|---|---|---|---|---|--|
| U | L | R | 2 | - | R | 0 | 0 | 1 | 5 | F | T | 2 | |
| 1 | | 2 | | | | 3 | 4 | | | | | | |

| 1 Type | 2 Value | 3 Tolerance | 4 Packing | |
|--|-------------------------------|----------------|-------------------|-----------|
| ULR1S, ULR1, ULR15S, ULR2N, ULR2, ULR25, ULR3, ULR3N, ULR5 | 3 to 6 characters R = ohms | F = $\pm 1\%$ | T2 = Plastic tape | |
| | | J = $\pm 5\%$ | All sizes | 2000/reel |

USA (IRC) Part Number: ULRB22512R0015FLFSLT (2512, 1.5 milliohms $\pm 1\%$, Pb-free)

| | | | | | | | | | | | | | | | | | | | |
|---|---|---|---|---|---|---|---|---|---|---|---|---|---|---|---|---|---|---|---|
| U | L | R | B | 2 | 2 | 5 | 1 | 2 | R | 0 | 0 | 1 | 5 | F | L | F | S | L | T |
| 1 | | 2 | | | 3 | | | 4 | 5 | 6 | | | | | | | | | |

| 1 Type | 2 Size | 3 Value | 4 Tolerance | 5 Termination | 6 Packing | |
|---|-----------|------------------------------|----------------|------------------|--------------------|-----------|
| ULRG1, ULRG15, ULRG2, ULRG25, ULRG3, ULRB1, ULRB2 | 1206 | 4 - 6 characters R = ohms | F = $\pm 1\%$ | LF = Pb-free | SLT = Plastic tape | |
| | 2010 | | J = $\pm 5\%$ | | All sizes | 2000/reel |
| | 2512 | | | | | |

General Note

TT Electronics reserves the right to make changes in product specification without notice or liability.
All information is subject to TT Electronics' own data and is considered accurate at time of going to print.