

Green High Voltage Chip Resistors

GHVC Series

- Completely free of Pb and its compounds
- RoHS compliant without exemption
- Anti-sulphur construction
- Continuous voltages up to 3kV
- Overload voltages up to 4kV
- Sizes 1206 to 2512

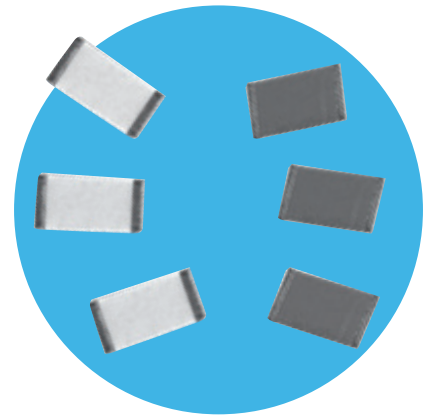

All parts are Pb-free and comply with EU Directive 2011/65/EU amended by (EU) 2015/863 (RoHS3)

Electrical Data

		1206	2010	2512	Notes
Power rating @70°C	watts	0.3	0.5	1	
Limiting element voltage	volts	1000	2000	3000	DC or AC peak
Maximum overload voltage (2s)	volts	1500	3000	4000	
Resistance range	ohms	25K to 100M			
Resistance tolerance	%	1,2,5,10			1206: 1% available up to 10M only
TCR	ppm/°C	100			
Ambient temperature range	°C	-55 to +125			
Values		E24 & E96 preferred			
Thermal Impedance	°C/W	200	80	70	

Physical Data

Dimensions (mm) & weight (mg)							
	L	W	T	A	B min	C	Wt. nom
1206	3.2±0.2	1.6±0.2	0.6±0.1	0.35±0.2	1.95	0.35±0.2	10
2010	5.1±0.3	2.5±0.2	0.7±0.1	0.45±0.2	3.7	0.4±0.25	35
2512	6.5±0.3	3.2±0.2	0.7±0.1	0.45±0.2	5	0.4±0.2	55

Wrap-around terminations (3 faces)

Construction

Resistive thick film material, overglaze and organic protection are screen printed on a 96% alumina substrate. The design and laser adjustment of the resistive element optimises the limiting element voltage of the resistor.

Terminations

The chips are supplied with Pb-free wrap-around terminations suitable for soldering.

Solderability

The terminations have an electroplated nickel barrier and tin finish. This ensures excellent 'leach' resistance properties and solderability.

Marking

The body protection is resistant to all normal cleaning solvents suitable for printed circuits. The chips are not marked and the relevant information on type, value, tolerance date code and quantity are recorded on the reel.

General Note

TT Electronics reserves the right to make changes in product specification without notice or liability. All information is subject to TT Electronics' own data and is considered accurate at time of going to print.

Performance Data

		Maximum	Typical
Load at rated power: 1000 hours rated load @ 70°C	ΔR%	1206: 2 2010/2512: 1	1206: 1 2010/2512: 0.25
Shelf life test: 12 months at room temperature	ΔR%	0.3	0.04
Derating from rated power at 70°C	ΔR%	Zero at 125°C	
Short term overload: Lesser of 6.25 x rated power or maximum overload voltage	ΔR%	2	0.2
Lightning strike: 1.2/50μs & 10/700μs - see graph for peak voltage	ΔR%	0.5	0.2
Dry heat: 1000 hours at 125°C	ΔR%	0.5	0.1
Long term damp heat	ΔR%	1	0.25
Temperature rapid change	ΔR%	0.5	0.1
Resistance to solder heat	ΔR%	0.25	0.05
Resistance to sulphur-bearing gas: ASTM-B-809		0.25	0.05
Voltage proof	volts	500	
Voltage coefficient of resistance	ppm/V	1206: -25	1206: -15
		2010: -15	2010: -5
		2512: -5	2512: -1.5

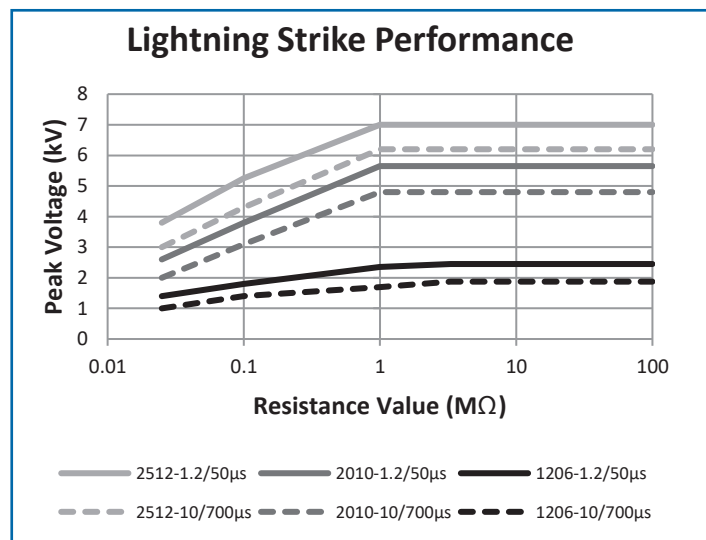
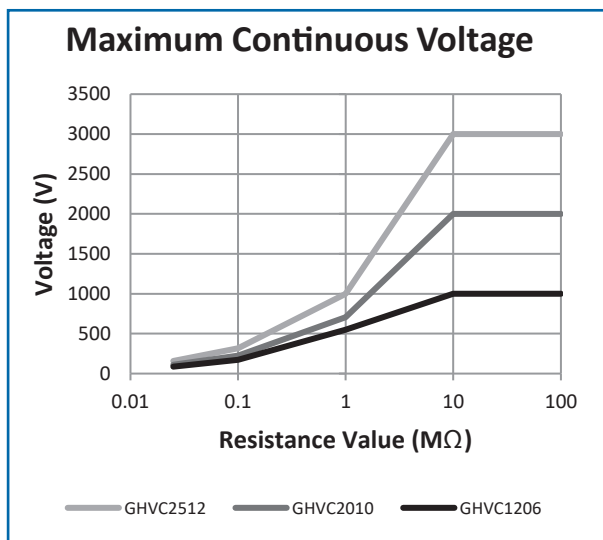

Application Notes

GHVC resistors are ideally suited for handling by automatic methods due to their rectangular shape and the small dimensional tolerances. Electrical connection to a ceramic substrate or to a printed circuit board can be made by reflow or wave soldering of wrap-around terminations.

Wrap-around terminations provide good leach properties and ensure reliable contact. Due to the robust construction, the GHVC can be immersed in the solder bath for 30 seconds at 260°C. This enables the resistor to be mounted on one side of a printed circuit board and wire-leaded components applied on the other side.

GHVC resistors themselves can operate at a maximum temperature of 125°C (see performance above). For soldered resistors, the joint temperature should not exceed 110°C. This condition is met when the stated power levels at 70°C are used.

The PCB layout should avoid tracks running between the GHVC mounting pads, as this would compromise the LEV.

The LEV stated applies to operation at sea-level pressure, in a non-condensing atmosphere and non-contaminating environment. Voltage derating should be applied if low pressure, high humidity or contamination may be encountered. The termination clearance dimension (B) should be used in conjunction with the creepage limit applicable to the circuit application in order to determine the derated LEV.

General Note

TT Electronics reserves the right to make changes in product specification without notice or liability. All information is subject to TT Electronics' own data and is considered accurate at time of going to print.

Packaging

GHVC Resistors are supplied taped and reeled as per IEC 286-3.

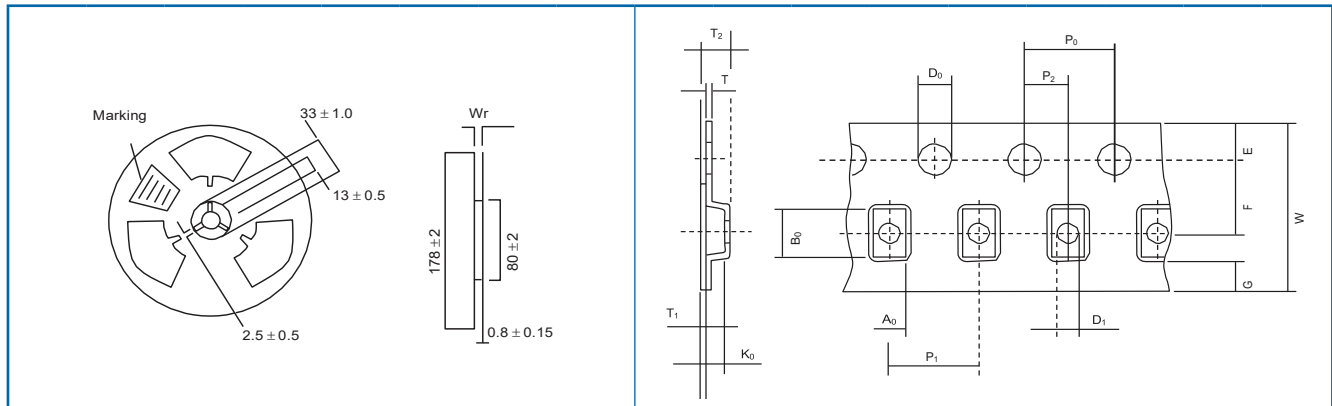

Tape and reel dimensions (mm)																Qty. per reel
	Wr	W	P1	P0	P2	D0	D1	E	F	A0	B0	K0	T	T1	T2	
	± 0.5	± 0.3	± 0.1	± 0.1	± 0.05	± 0.1	± 0.2	± 0.1	± 0.05	± 0.1	± 0.1	± 0.1	± 0.05	Nom.	± 0.15	
1206	9	8	4	4	2	1.5	1	1.75	3.5	1.95	3.55	1.0	0.2	0.05	1.3	3000
2010	13	12	4	4	2	1.5	1.5	1.75	5.5	2.79	5.89	0.91	0.28	0.06	1.21	3000
2512	13	12	8	4	2	1.5	1.5	1.75	5.5	3.61	6.96	1.17	0.28	0.06	1.45	1800

Ordering Procedure

Example: GHVC2512-1M0FT18 (2512, 1 megohm, $\pm 1\%$, 1800 pcs on a reel, Pb-free)



1	2	3	4	5
Type	Size	Value	Tolerance	Packing
GHVC	1206	E24 = 3/4 characters	F = $\pm 1\%$	T3 1206, 2010 3000/reel
	2010	E96 = 3/4 characters	G = $\pm 2\%$	T18 2512 1800/reel
	2512	K = kilohms M = megohms	J = $\pm 5\%$ K = $\pm 10\%$	

General Note

TT Electronics reserves the right to make changes in product specification without notice or liability. All information is subject to TT Electronics' own data and is considered accurate at time of going to print.