

Printed circuit board terminals for the Reflow soldering process

LP 5.08/90-THR
LM 3.5/90-THR
LMZF 5.08/90-THR

INNOVATION

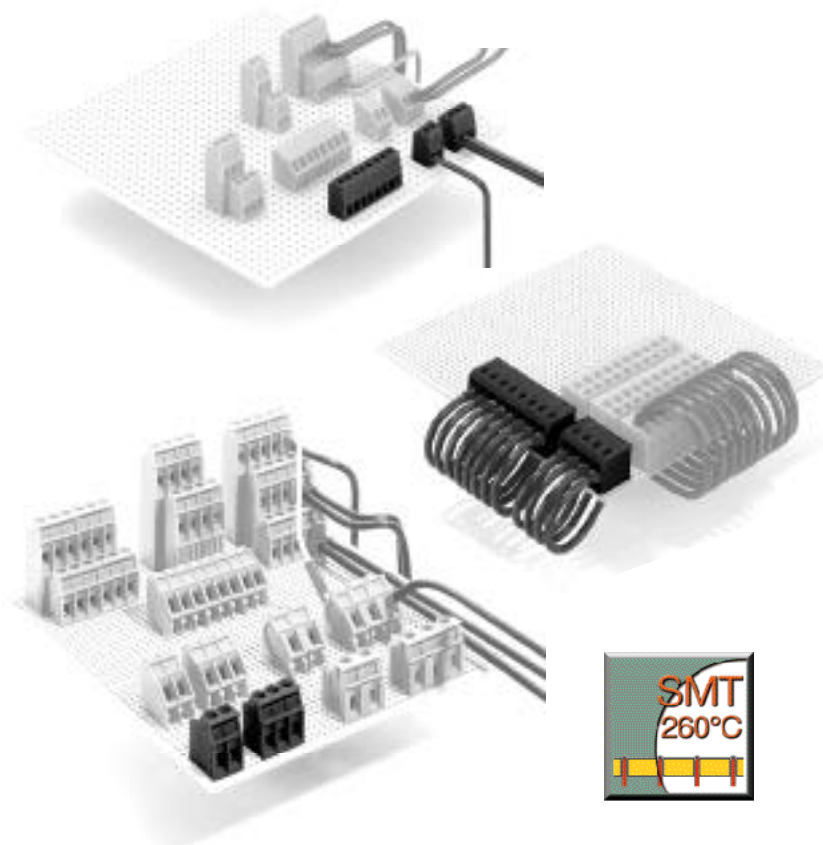

The new Through-Hole-Reflow (THR) terminal blocks are molded from a high temperature resistant material that is suitable for the SMT reflow soldering process. This new feature allows customers to eliminate the secondary wave or hand soldering operation, thus reducing production steps, time, and costs.

Advantages:

- temperature resistant in the soldering process up to 260 °C
- suitable for Through-Hole-Reflow (THR) soldering in the reflow soldering processes
- allows customers to eliminate the secondary wave or hand soldering operation, thus reducing costs

United States

Weidmüller Inc.
821 Southlake Blvd.
Richmond, Virginia 23236
Telephone: (800) 849-9343
Facsimile: (804) 379-2593
Email: info@weidmuller.com
Website: www.weidmuller.com

Canada

Weidmüller Ltd.
10 Spy Court
Markham, Ontario L3R-5H6
Telephone: (800) 268-4080
Facsimile: (905) 475-2798
Email: info1@weidmuller.ca
Website: www.weidmuller.ca

Mexico

Weidmüller, S.A. de C.V.
5 Sur No. 4311
Col. Huexotitla
72534 Puebla, Pue. Mexico
Telephone: (22) 37 2549
Facsimile: (22) 43 1981
Email: weidmull@acnet.net

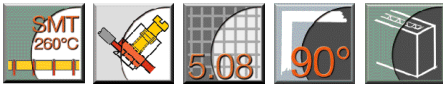

Weidmüller's top-of the line fixed terminal block series is now available in a version suitable for the reflow soldering process. It features a high-temperature resistant housing and a gas-tight maintenance-free clamping yoke connection that accommodates up to 12 AWG wires.

The LP series has a full range of accessories and is suitable for a wide range of applications.

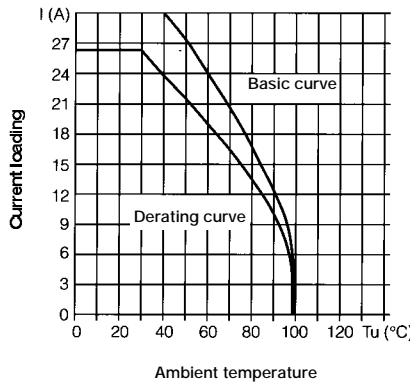

LP 5.08/6/90 with conductor H07V-K 2.5 mm²

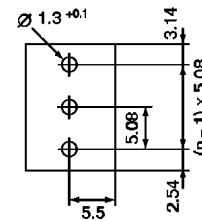
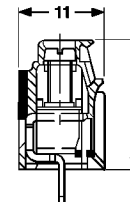

Materials	
Insulation material	
Color	
Temperature range	°C
Flammability class.	UL94
Contact base material	
Contact plating	

PA 4.6
black
-20... +100
V-2
Cu alloy
tin-plated

System characteristic values	
Pitch	mm
Connection method	
Processing method	
Recommended dimensions of the solder paste deposit ¹⁾	Ømm
Solder pin length	mm
PCB hole diameter	Ømm
Insulation stripping length	mm
Clamping screw	M
Insulation resistance	M
Through resistance	m
Torque	Nm

5.08
Through-Hole-Solder / Screw clamp connection
Reflow-Solder
3.5
3.2
1.3 ^{+0.1}
7.0
3
10 ³
1.2
0.5 ... 0.6

Conductor size	
Clamping range	mm ²
e solid H05(07) V-U	mm ²
f flexible H05(07) V-K	mm ²
f with ferrule to DIN 46228/1	mm ²
... with plastic collar to DIN 46228/4	mm ²
Gauge to EN 60999	mm (size)

0.13... 4.0
0.5... 4.0
0.5... 2.5
0.5... 2.5
-
2.8 x 2.4 (A3)

VDE 0110 4.97 rated data	
Rated cross-section to EN 60999	mm ²
Rated current ³⁾	A
Overvoltage category / Pollution severity	
Rated voltage	V
Impulse voltage	kV

4.0	4.0	4.0
25	25	25
III/3	III/2	II/2
250	250	500
4.0	4.0	4.0

UL rated data	
Rated voltage, industrial	V~
Rated current	A
AWG conductor (field wiring)	

300
15
26...12

CSA rated data	
Rated voltage, industrial	V~
Rated current	A
AWG conductor (field wiring)	

300
15
26...12

Application notes

- per solder pin: at 1.6 mm pcb thickness, 1.3 mm soldering hole diameter, 2.3 mm soldering pad diameter, 50% metal content/volume of the solder paste. Values for other parameters on request.
- referred to 20°C ambient temperature, rated cross-section and number of poles

For the mounting of PCBs, it should be noted that the rated data given in the catalogue relate only to the connection elements. The necessary creepage and clearance paths must be observed in connection with the respective applicant in accordance with VDE 0110. The current-carrying capacity is to be determined according to DIN IEC 326 part 3.

Weidmüller connectors are tested according to the DIN VDE 0627 standard, and are valid for its field of applications. Provided that the connectors are used for the intended purpose, all requirements with respect to the occurring of electrical, mechanical, thermic and corrosive stress will be satisfied.

Ordering Data

Soldering pin length 3.2 mm

Color: Black

Poles	Type	Part No.	Box Qty.
2	LP 5.08/2/90-THR	1789150000	100
3	LP 5.08/3/90-THR	1789160000	100

Free standing 2 and 3 pole modules are available. We do not recommend dovetailing modules to higher pole counts.

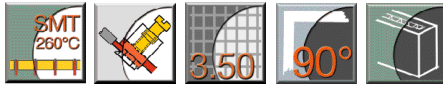

When space for a terminal block on the board is limited, the pcb terminals of the 3.5 mm pitch LM system are the right choice.

The LM features compact outer dimensions, yet still has a large wire entry that accomodates up to 14 AWG wires, for a wide range of applications.

- Space savings on the board: up to 48% more space on the board compared to 5.00/5.08 mm pitch terminal blocks.

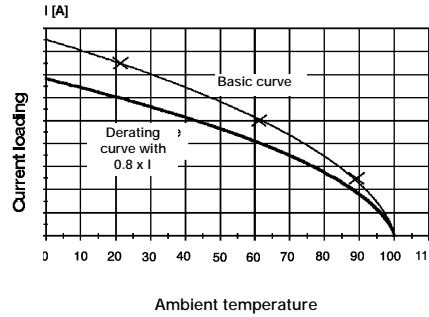

LM 3.5/24/90 3.2 OR with Conductor H07V-K1.5 mm²



Materials

Insulation material	
Color	
Temperature range	°C
Flammability class.	UL94
Contact base material	
Contact plating	

PA 4.6
black
-20... +100
V-2
CuSn
tin-plated

System characteristic values

Pitch	mm
Connection method	
Processing method	
Recommended dimensions of the solder paste deposit ¹⁾	Ømm
Solder pin length	mm
PCB hole diameter	Ømm
Insulation stripping length	mm
Clamping screw	M
Insulation resistance	M
Through resistance	m
Torque	Nm

3.50
Through-Hole-Solder / Screw clamp connection
Reflow-Solder
3.5
3.2
1.3 ^{+0.1}
5.0
2
10 ³
2.2
0.2 ...0.25

Conductor size

Clamping range	mm ²
e solid H05(07) V-U	mm ²
f flexible H05(07) V-K	mm ²
f with ferrule to DIN 46228/1	mm ²
... with plastic collar to DIN 46228/4	mm ²
Gauge to EN 60999	mm (size)

0.08... 1.5
0.5... 1.5
0.5... 1.5
-
-
2.4 x 1.5 (A1)

VDE 0110 4.97 rated data

Rated cross-section to EN 60999	mm ²
Rated current ³⁾	A
Overvoltage category / Pollution severity	III/3 III/2 II/2
Rated voltage	V
Impulse voltage	kV

1.5
12
125 200 320
2.5 2.5 2.5

UL rated data

Rated voltage, industrial	V~
Rated current	A
AWG conductor (field wiring)	

300
10
22...14

CSA rated data

Rated voltage, industrial	V~
Rated current	A
AWG conductor (field wiring)	

300
10
28...14

Application notes

- per solder pin: at 1.6 mm pcb thickness, 1.3 mm soldering hole diameter, 2.3 mm soldering pad diameter, 50% metal content/volume of the solder paste. Values for other parameters on request.
- referred to 20°C ambient temperature, rated cross-section and number of poles

For the mounting of PCBs, it should be noted that the rated data given in the catalogue relate only to the connection elements. The necessary creepage and clearance paths must be observed in connection with the respective applicant in accordance to VDE 0110. The current-carrying capacity is to be determined according to DIN IEC 326 part 3.

Weidmüller connectors are tested according to the DIN VDE 0627 standard, and are valid for its field of applications. Provided that the connectors are used for the intended purpose, all requirements with respect to the occurring of electrical, mechanical, thermic and corrosive stress will be satisfied.

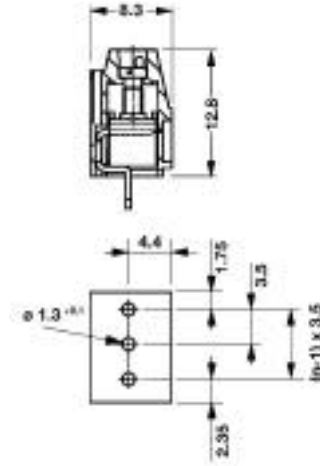

Ordering Data

Soldering pin length 3.2 mm

Color: Black

Poles	Type	Part No.	Box Qty.
2	LM 3.5/2/90-THR	1789130000	100
3	LM 3.5/3/90-THR	1789140000	100

Free standing 2 and 3 pole modules are available. We do not recommend dovetailing modules to higher pole counts.

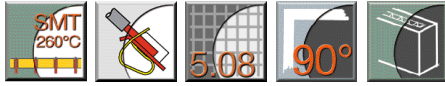

Short wiring time is the main feature of the LMZF 5.08/90 pcb terminals with tension clamp connection. The tension clamp is easy to actuate and reduces wiring time compared to screw clamp terminals.

Two soldering pins securely anchor the terminal onto the printed circuit board and prevent damage to the soldering joint even if high actuating forces are applied.

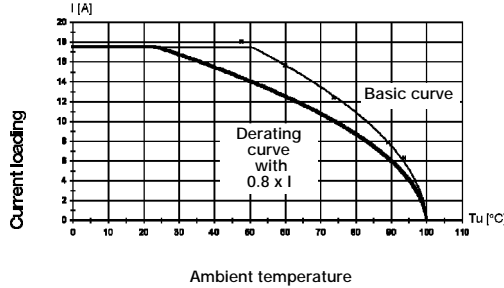

LMZF 5.08/90/6 poles with conductor H07V-K1.5 mm²

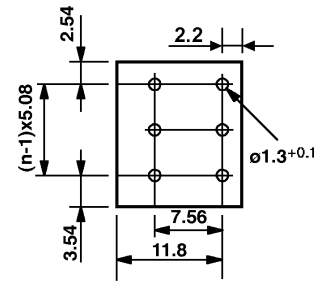
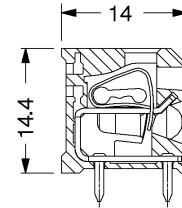

Materials	
Insulation material	
Color	
Temperature range	°C
Flammability class.	UL94
Contact base material	
Contact plating	
System characteristic values	
Pitch	mm
Connection method	
Processing method	
Recommended dimensions of the solder paste deposit ¹⁾	Ømm
Solder pin length	mm
PCB hole diameter	Ømm
Insulation stripping length	mm
Clamping screw	M
Insulation resistance	M
Through resistance	m
Torque	Nm

PA 4.6	
black	
-20... +100	
V-2	
E-Cu	
tin-plated	
5.08	
Through-Hole-Solder / Tension clamp connection	
Reflow-Solder	
3.5	
3.2	
1.3 ^{+0.1}	
7.0	
-	
-	
10 ³	
1.3	
-	

Conductor size	
Clamping range	mm ²
e solid H05(07) V-U	mm ²
f flexible H05(07) V-K	mm ²
f with ferrule to DIN 46228/1	mm ²
... with plastic collar to DIN 46228/4	mm ²
Gauge to EN 60999	mm (size)

0.14... 1.5	
0.5... 1.5	
0.5... 1.5	
0.5... 1.5	
-	
2.4 x 1.5 (A1)	

VDE 0110 4.97 rated data	
Rated cross-section to EN 60999	mm ²
Rated current ³⁾	A
Overvoltage category / Pollution severity	
Rated voltage	V
Impulse voltage	kV

1.5		
14		
III/3	III/2	II/2
250	400	630
4.0	4.0	4.0

UL rated data	
Rated voltage, industrial	V~
Rated current	A
AWG conductor (field wiring)	

300	
10	
26... 14	

CSA rated data	
Rated voltage, industrial	V~
Rated current	A
AWG conductor (field wiring)	

300	
10	
26... 14	

Application notes

- 1) per solder pin; at 1.6 mm pcb thickness, 1.3 mm soldering hole diameter, 2.3 mm soldering pad diameter, 50% metal content/volume of the solder paste. Values for other parameters on request.
- 3) referred to 20°C ambient temperature, rated cross-section and number of poles

For the mounting of PCBs, it should be noted that the rated data given in the catalogue relate only to the connection elements. The necessary creepage and clearance paths must be observed in connection with the respective applicant in accordance to VDE 0110. The current-carrying capacity is to be determined according to DIN IEC 326 part 3.

Weidmüller connectors are tested according to the DIN VDE 0627 standard, and are valid for its field of applications. Provided that the connectors are used for the intended purpose, all requirements with respect to the occurring of electrical, mechanical, thermic and corrosive stress will be satisfied.

Ordering Data

Soldering pin length 3.2 mm

Color: Black

Poles	Type	Part No.	Box Qty.
2	LMZF 5.08/2/90-THR	1784540000	100

Free standing 2 pole modules are available. We do not recommend dovetailing modules to higher pole counts.