

# Digital signalling

<b>Digital signalling</b>	
Relays – overview	C.2
Relays – DK-SERIES	C.8
Relays – MCZ-SERIES	C.12
Relays – MCZ-TRAK-SERIES	C.14
Relays – MCZ-SERIES accessories	C.16
Relays – MICROSERIES	C.18
PLC digital interfaces	C.24
Relays – PLUGSERIES	C.26
Relays – RIDERSERIES	C.32
Relays – RS-SERIES – RS 30	C.68
Relays – RS-SERIES – RS 31	C.70
Relays – RS-SERIES – RS 32	C.72
Relays – RS-SERIES – RS 32 Safety	C.75
Relays – RS-SERIES – with RSM multiple interface	C.76
Relays – WAVESERIES	C.78
Optos – overview	C.84
Optos – DK-SERIES	C.88
Optos – MCZ-SERIES	C.93
Optos – MCZ-TRAK-SERIES	C.96
Optos – MICROSERIES	C.98
Optos – PLUGSERIES	C.104
Optos – RSO-SERIES	C.108
Optos – WAVESERIES	C.110
Timer relays – BT-SERIES	C.116
Timer relay – DK-SERIES	C.122
Timer relay – MCZ-SERIES	C.125
Function components	C.126

# Housing forms for relays

## DK-SERIES



All components of the DKR mini-coupler are extremely slim: the use of the latest surface-mounted devices (SMD) allows us to keep the width to just 6 mm. The mini-couplers support a wide range of applications relating to the coupling of digital sensor/actuator signals with automation devices and the process field. DKR relays are designed to pick up and standardise signals of different voltages from the field.

## MICROSERIES



The **MICROSERIES** range integrates the product features of the RSS power relay into the world of terminals. The user therefore benefits from the special features of terminals by retaining a free choice of connection systems, plug-in cross-connections, standardised marking solutions as well as the space saving advantage typical of relays!

## RIDERSERIES



The **RIDERSERIES** range represents the successful integration of the families RCL, RCI, RCM, RRD and RPW into the Weidmüller relay programme. This modular series conforms to the international standard. The many pluggable variants are available from 1 way to 4-way changeover contacts with a free choice of connection system.

## MCZ-SERIES



The MCZ enclosure is only 6 mm wide and one of the narrowest of its kind. Its outstanding technical features include:

- Tension clamp connection to reduce assembly costs
- Integrated cross-connection in input and output minimizes wiring workload

## PLUGSERIES



The **PLUGSERIES** offers you proven product features from the world of connection systems combined with the performance of the Weidmüller RCL power relay. The plug-in cross-connection ZQV enables quick and easy bridging of input and output potentials. Besides a free choice of connection systems, PLUGSERIES products are unique as a result of the Wemid housing material.

## RS-SERIES



Clip-on bases with relays RS 30, 31, 32 have a width of 11.2 mm to 25 mm – depending on the type. RSM multiple interfaces are assembled with a choice of 4, 8 or 16 relays. Versions with a common plus or minus potential are available to save wiring on the input side. LP connection elements are equipped with clamping yoke units for screw connection.

## WAVESERIES

---



Innovative electronic components require a housing or enclosure that reflects their specific functions. They must allow adjustment and operation functions and support electro-mechanical requirements such as heat dissipation or electromagnetic compatibility. A compact design saves space in the control cabinet and reduces assembly costs. Ergonomic design is increasingly important for top-quality relay interfaces.

## JACKPAC®

---



JACKPAC® integrates basic functions of signal processing such as amplification, isolation and conversion of signals, but also provides protective functions thanks to packaging to IP68 standard that is compatible with field wiring conditions. This allows you to both realise decentralised wiring concepts without having to accept a compromise solution and optimally use digital input-output modules from the IP6X world.

# Relays – overview

## Switching large and small capacities

Basically, the reliability of the contacts in a relay reaches a maximum at a medium current load thanks to the continuous self-cleaning effect. As the contact load increases and hence leads to more severe erosion of the contacts, the switching reliability decreases with an increasing number of switching operations. This reduces the service life of the contacts. Although at very low loads the minimal erosion of the contacts does raise the service life more or less to the level of the mechanical service life, the lack of a self-cleaning effect contributes to a lower contact reliability.

Reliable contact at low currents, especially when only small voltages are involved as well, depends on the choice of contact material. Contacts of silver-nickel, which is standard for the majority of Weidmüller relays, are generally suitable for currents of approx. 10 mA and higher. Such large-surface contacts can switch both low and high currents. However, at low currents occasional failures can occur due to erosion and the lack of the self-cleaning effect. The higher the current, the more reliable is the contact – thanks to the self-cleaning. Silver-nickel is suitable as a contact material for low currents/voltages. It provides, however, only **moderate switching reliability**. If this is acceptable, then conventional standard relays represent an inexpensive solution.

For applications that call for **improved contact reliability** or low currents/voltages, conventional relays with hard-plated gold contacts are preferable because they do not erode and therefore operate more reliably.

If **maximum switching reliability** is necessary, especially for low currents/voltages, a relay should not be your first choice. In these instances Weidmüller advises the use of optos. Wear and abrasion caused by mechanical movements are non-existent in optos.

## Protective circuits for the contacts

The switching of inductive or capacitive loads produces switching sparks which can influence the electrical service life of the relays. The following protective circuits for the contacts reduce contact wear:

### Diode

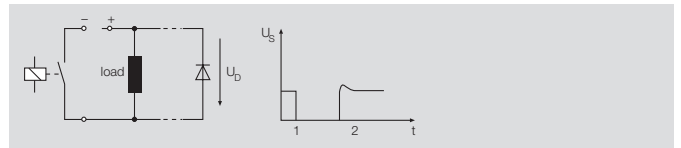

Advantage: Can be used for all capacities, low surge, minimum space required, low price  
 Disadvantage: Very long release delay

### Diode and Z-diode

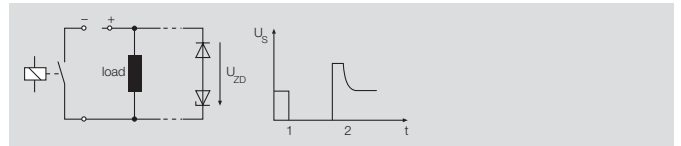

Advantage: Low surge (defined by Z-diode), short release delay  
 Disadvantage: Cannot be used for large capacities

### Varistor

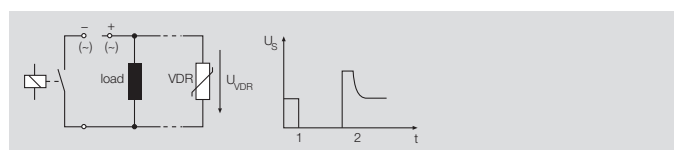

Advantage: Low surge, short release delay  
 Disadvantage: High current load on the contacts when switching on; more complicated and expensive at greater capacities

### RC combination

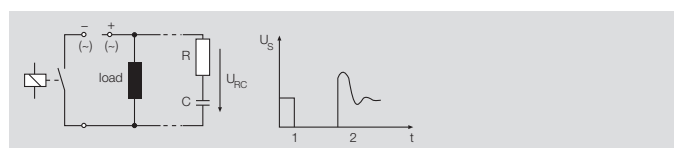

Advantage: Short release delay, low price  
 Disadvantage: Cannot be used for all operating voltages and capacities

$U_S$  = Voltage progression      1 = Closing      2 = Opening

### Principal characteristics of relay contacts

Although every relay contact has its own characteristics, the performance curves are very similar in terms of shape, but not in terms of the actual values. The examples below show curves for

- contact lifetime (number of make-break operations plotted against make-break capacity)
- DC limit curve (direct current plotted against direct voltage)
- reduction factor for inductive load (reduction factor plotted against  $\cos \varphi$ )

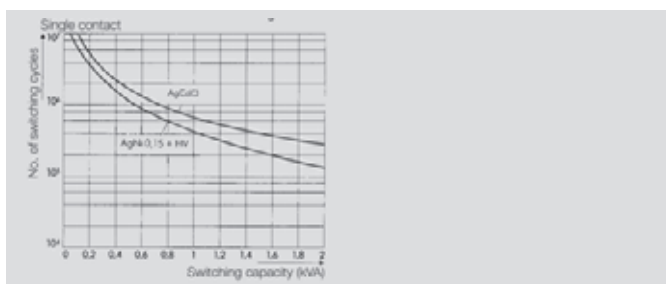

Contact lifetime for ohmic load

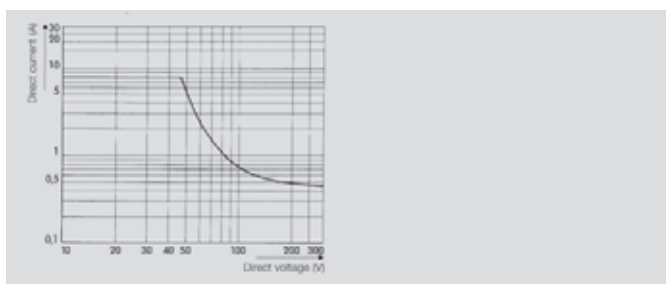

DC limit curve for ohmic load

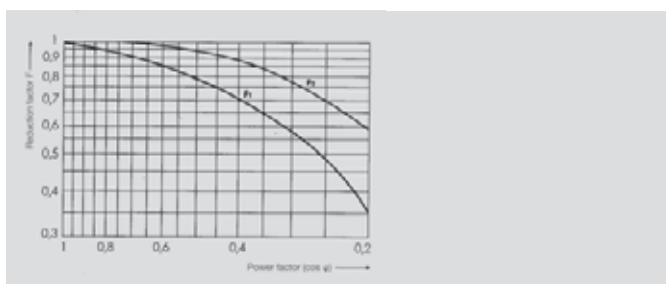

Reduction factor for inductive load  $\cos \varphi < 1$   
 Eff. make-break op. = make-break operations for  $(\cos \varphi = 1) \times$

### Derating curve

The transition resistance of the relay contacts is a key factor contributing to temperature increase inside the relay modules. This relationship is illustrated by a derating curve, defined as the function of the permissible current plotted against the ambient temperature.

The permissible current (curve a) is determined for the following operating conditions:

- Continuous operation
- Rated input voltage + 10 percent
- Several relay modules working under load, mounted horizontally in rows on mounting rail, without any spacing

If the modules are mounted with a spacing > 20 mm, this results in a higher current load (curve b). Curve b also shows the maximum values for switching or short-time operation when mounted horizontally.

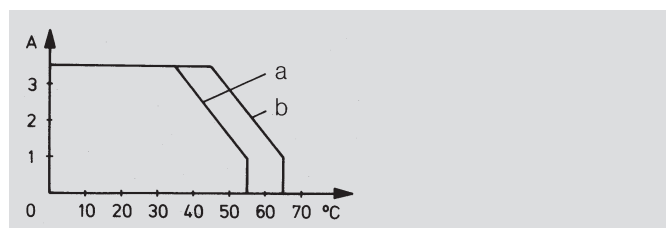

# Relays – overview

## Contact materials

### AgNi Au (silver-nickel hard gold plated)

For dry loads, measuring and switching circuits, control inputs (1 mV – 10 V, 0.1 mA – 100 mA).

### AgNi 0.15 (fine-grain silver)

Suitable for low to medium loads, AC and DC loads, resistive and inductive (solenoid valves, fans, heaters); not suitable for high inrush currents.

### AgNi 90/10 (silver-nickel)

Suitable for all loads, constantly low contact-circuit resistances in the low load range, AC and DC loads, resistive and inductive (solenoid valves, fans, heaters); not suitable for capacitive inrush currents.

### AgSnO<sub>2</sub> 90/10 (silver-tin oxide)

Suitable for all loads. Well suited to higher loads. Particularly well suited to high inrush currents with short rise times (lamp loads, capacitive loads, fluorescent tubes, switch-mode power supplies, etc.). Well suited to resistive, inductive and capacitive DC applications due to low material transport.

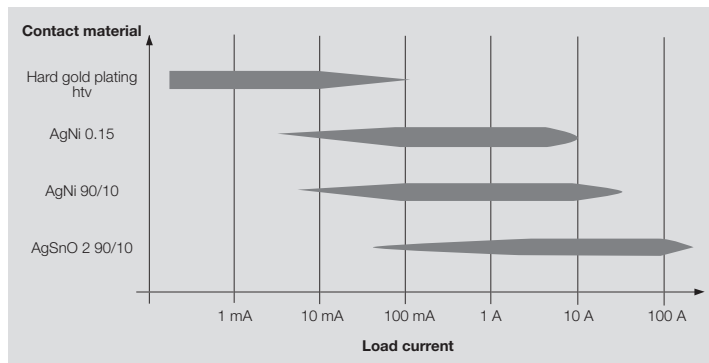

## Definition of technical data

Input Circuit	
Nominal voltage [V]	Reference voltage at which the relays operates; typical input voltages = > 5 V DC, 12, 24, 48, 60, 115, 230 AC/DC
Nominal current [mA]	Input voltage and input resistance; input resistance = > coil resistance + resistance of triggering device (R, LED, GL ...)
Nominal power [W/VA]	Input voltage x input current DC/AC with tolerance $\pm 10\%$ or $+5/-15\%$ , typical range for relays 250 mW ... 1 W or 0.4 VA ... 1.2 VA
Response voltage [V]	Smallest input voltage required for the relays to respond ( $T_u = 293\text{ K}$ )
Pick-up current [mA]	Smallest input current at which the relay switches from normal to operating position ( $T_u = 293\text{ K}$ )
Pick-up power [W/VA]	Product of response voltage and pick-up current
Drop-out voltage [V]	Voltage level at which the relay reliably drops out
Drop-out current [mA]	Input current at which the relay reliably drops out
Output Circuit	
Max. switching voltage [V]	Max. voltage that can be applied to the relay contact
Making current [A]	The current allowed to flow for max. 4 seconds after the relay contact closes
Continuous current [A]	Current allowed to flow continuously after the contact closes
Switching power [W/VA]	Product of output voltage and making current for resistive, inductive or capacitive load
Min. switching power [ $\mu\text{W}$ ]	Smallest power that can be switched via the contact
Service life	Number of switching operations until the contact fails – mechanical = > without electrical load – electrical = > under resistive or inductive AC/DC load
Response time [ms]	Time until contact closes/opens after switching the excitation voltage
Drop-out time [ms]	Time until contact closes/opens after opening the excitation current circuit
Switching frequency [Hz]	Switching operations per second in pulse duty factor 1 : 2 ( $t_{on} = t_{off}$ )
Dielectric strength [kV]	Max. test voltage between input and output circuits that does not result in a discharge
Protective separation	Relays to EN 50178 and VDE 0106 part 101

Relays - DK-SERIES

1 NO contact  
input bottom  
DC/UC coil

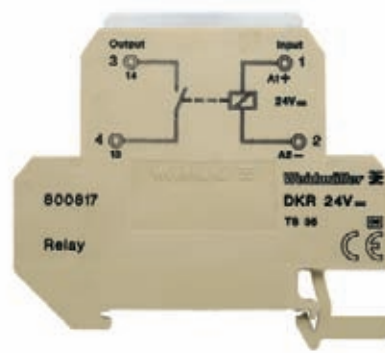

C

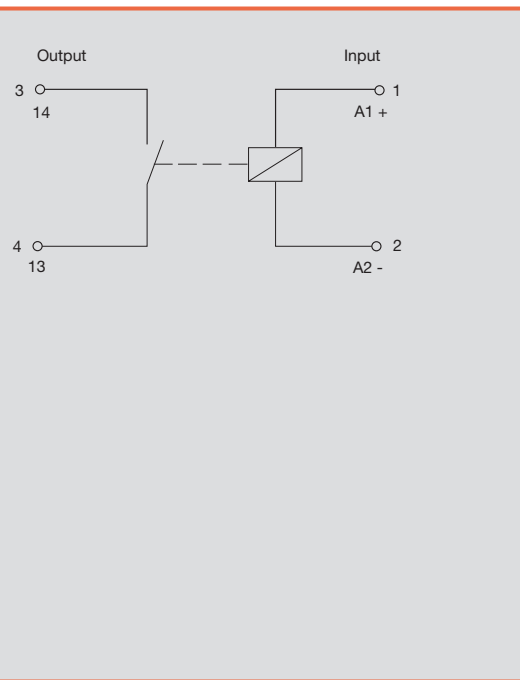

Output	
max. switching voltage AC1/Continuous current	100 V/0.5 A
min. switching power	1 V / 1 mA
Response time / Drop-out time	typically 0.7...2.5 ms/0.2...2 ms
Contact base material	Rh/Ru
Mechanical endurance	10 <sup>7</sup> switching cycles
max. switching frequency at rated load	200.0 Hz
Rated data	
Status indicator/Free wheel diode	green LED/Yes
Reverse pol. prot	available
Operating temperature	-25 °C...+40 °C
Storage temperature	-40 °C...+60 °C
Humidity	40°C/93% RH, no condensation
Approvals	CE;
Insulation coordination (EN 50178)	
Standards	EN 50178
Rated voltage	150 V
Impulse withstand voltage	1.5 kV
Creepage and clearance path input - output	≥ 3 mm
Surge category	III
Pollution severity	2
Protective separation to VDE 0106 part 101	no
Dimensions	
Clamping range (rating- / min. / max.)	mm <sup>2</sup> 4 / 0.5 / 4
Length x width x height	mm 77 / 6 / 62
Note	
End plate AP DKT4: 0687560000	

Ordering data	5 V DC 1NO	12 V DC 1NO	24 V UC 1NO	24 V DC 1NO
<b>Input</b>				
Rated voltage	5 V DC ±5%	12 V DC ±10 %	24 V UC ±10 %	24 V DC +5% / -10%
Rated current AC			15 mA	
Rated current DC	12.5mA	12 mA	9 mA	9.3 mA
Power rating	65 mW	144 mW	0,36 VA / 216 mW	225 mW
AC Response/dropout Volt			12 V / 8 V	
DC Response/dropout Volt	4.4 V	9 V	11 V / 10 V	11 V
AC pickup/dropout current			6,3 mA / 4,3 mA	
DC pickup/dropout current	11.8 mA	10 mA	3,8 mA / 3 mA	7.5 mA
<b>Ordering data</b>				
For TS 32				
Type			DKR 32 24VUC 1A	DKR 32 24VDC 1A
Order No.			<b>8008110000</b>	<b>8016620000</b>
For TS 35				
Type	DKR 35 5VDC 1A	DKR 35 12VDC 1A	DKR 35 24VUC 1A	DKR 35 24VDC 1A
Order No.	<b>8019610000</b>	<b>8171100000</b>	<b>8016610000</b>	<b>8008170000</b>
<b>Ordering data</b>				
Type				
Order No.				
<b>Note</b>				

1 change-over contact  
input bottom DC coil

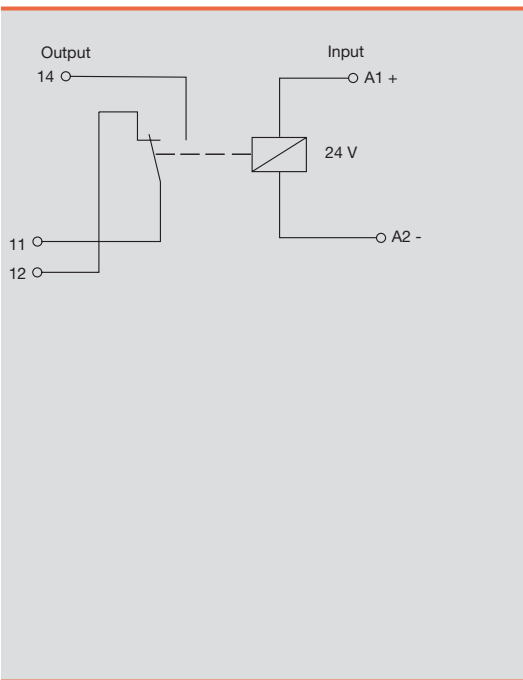
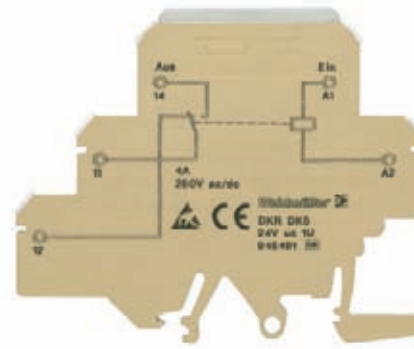

Output	
max. switching voltage AC/Continuous current	250 V/6 A
min. switching power	5 V / 10 mA
Response time / Drop-out time	6 ms/15 ms AC; 8 ms DC
Contact base material	AgSnO2
Mechanical endurance	2*10 <sup>7</sup> switching cycles
max. switching frequency at rated load	0.1 Hz
Rated data	
Status indicator/Free wheel diode	green LED/Yes
Reverse pol. prot	not available
Operating temperature	-40 °C...+60 °C
Storage temperature	-40 °C...+60 °C
Humidity	40°C/93% RH, no condensation
Approvals	CE;
Insulation coordination (EN 50178)	
Standards	EN 50178
Rated voltage	300 V
Impulse withstand voltage	4 kV
Creepage and clearance path input - output	≥ 8 mm
Surge category	III
Pollution severity	2
Protective separation to VDE 0106 part 101	no
Dimensions	
Clamping range (rating- / min. / max.)	mm <sup>2</sup> 4 / 0.5 / 4
Length x width x height	mm 77 / 6 / 62
Note	
End plate AP DK5: 8268870000, AP DKT4: 0687560000	

Ordering data

24 V UC 1CO

Input	
Rated voltage	24 V DC ±20 %
Rated current AC	9 mA
Rated current DC	7 mA
Power rating	220 mVA/ 180 mW
AC Response/dropout Volt	18 V
DC Response/dropout Volt	19 V
AC pickup/dropout current	7 mA
DC pickup/dropout current	5.5 mA

Ordering data

For TS 32	Type	DKR DK5 24VUC 1U			
	Order No.	<b>9454910000</b>			
For TS 35	Type	DKR DK5 24VUC 1U			
	Order No.	<b>9454910000</b>			

Ordering data

Type  
Order No.

Note

Relays - DK-SERIES

1 change-over contact  
input bottomDC/UC coil



C

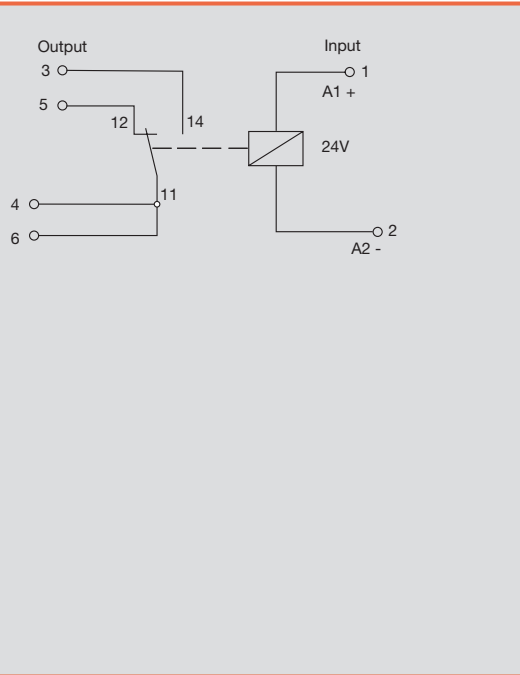

Output	
max. switching voltage AC1/Continuous current	250 V/6 A
min. switching power	10 V / 100 mA
Response time / Drop-out time	typically 0.7...2.5 ms/0.2...2 ms
Contact base material	AgNi 0.15 gold flashed
Mechanical endurance	≥10 <sup>7</sup> switching cycles
max. switching frequency at rated load	10.0 Hz
Rated data	
Status indicator/Free wheel diode	green LED/Yes
Reverse pol. prot	available
Operating temperature	-25 °C...+40 °C
Storage temperature	-40 °C...+60 °C
Humidity	40°C/93% RH, no condensation
Approvals	CE;
Insulation coordination (EN 50178)	
Standards	EN 50178
Rated voltage	300 V
Impulse withstand voltage	6 kV
Creepage and clearance path input - output	≥ 8 mm
Surge category	IV
Pollution severity	2
Protective separation to VDE 0106 part 101	no
Dimensions	
Clamping range (rating- / min. / max.)	mm <sup>2</sup> 4 / 0.5 / 4
Length x width x height	mm 65 / 18 / 62
Screw connection	
Tension clamp connection	
<b>Note</b>	
End plate AP DKT4: 0687560000	

Ordering data	24 V DC 1CO	24 V UC 1CO		
<b>Input</b>				
Rated voltage	24 V DC ±20 %	24 V DC ±20 %		
Rated current AC		20 mA		
Rated current DC	11.5 mA	16 mA		
Power rating	384 mW	480 mW / 400 mW		
AC Response/dropout Volt		18 V		
DC Response/dropout Volt	19 V	18 V		
AC pickup/dropout current		12.8 mA		
DC pickup/dropout current	9 mA	11.5 mA		
<b>Ordering data</b>				
For TS 32	Type			
	Order No.			
For TS 35	Type	DKR 35 24VDC 1U	DKR 35 24VUC 1U	
	Order No.	<b>8181980000</b>	<b>8181970000</b>	
<b>Ordering data</b>				
	Type			
	Order No.			
<b>Note</b>				



**Relays - MCZ-SERIES**

**Mini-conditioner MCZ R**  
**1 change-over contact**  
**AC/ DC/ UC coil**

Module can be used as an universal interface between control and actuator to switch small and medium-sized loads.

- 1 change-over contact
- Pluggable cross-connection at input and output minimises the wiring workload.
- 6 mm wide, low height



**C**

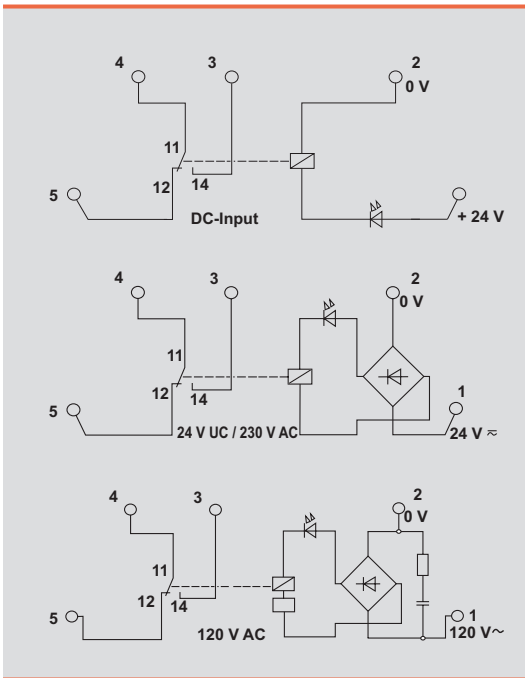

Output		
max. switching voltage AC1/Continuous current	400 V/6 A	
min. switching power	5 V / 10 mA	
Response time / Drop-out time	4.5 ms/10 ms	
Contact base material	AgSnO2	
Mechanical endurance	20*10 <sup>6</sup> switching cycles	
max. switching frequency at rated load	0.1 Hz	
Rated data		
Status indicator/Free wheel diode	green LED/Yes	
Reverse pol. prot	available	
Operating temperature	-25 °C...+ 55 °C	
Storage temperature	-40 °C...+60 °C	
Humidity	40°C/93% RH, no condensation	
Approvals	CSA;cJURus;CE;GL;	
Insulation coordination (EN 50178)		
Standards	EN 50178	
Rated voltage	300 V	
Impulse withstand voltage	6 kV	
Creepage and clearance path input - output	≥ 5.5 mm	
Surge category	III	
Pollution severity	2	
Protective separation to VDE 0106 part 101	yes	
Dimensions		
Clamping range (rating- / min. / max.)	mm <sup>2</sup>	1.5 / 0.5 / 2.5
Length x width x height	mm	91 / 6 / 63.2
<b>Note</b>	End plate AP MCZ 1.5: 8389030000 for cross-connectors and markers see MCZ Series accessories	

**Applications**

Limit curve

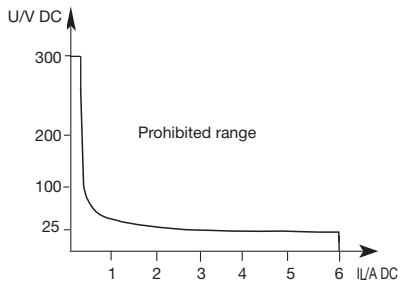

Derating curve

— in a row without spacing on terminal rail  
 - - - in a row with 20 mm spacing on terminal rail

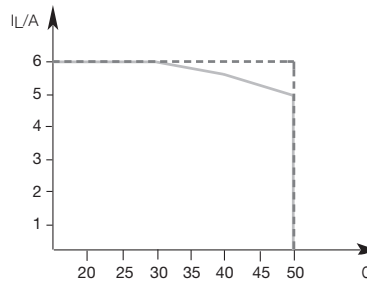

**Mini-conditioner MCZ R**  
**1 change-over contact**  
**AC/ DC/ UC coil**

Ordering data	24 V DC 1CO	24 V DC 1CO Au	24 V UC 1CO	60 V DC 1CO
<b>Input</b>				
Rated voltage	24 V DC ±20 %	24 V DC ±20 %	24 V UC ±10 %	5 V DC ±20%
Rated current AC			10.8 mA	
Rated current DC	6.3 mA	6.3 mA	6.1 mA	3 mA
Power rating	156 mW	156 mW	160 mVA / 150 mW	180 mW
AC Response/dropout Volt			approx. 17 V/approx. 7 V	
DC Response/dropout Volt	12 V...19 V/4 V...5,5 V	12 V...19 V/4 V...5,5 V	approx. 19 V/approx. 4 V	approx. 38 V/approx. 14 V
AC pickup/dropout current				
DC pickup/dropout current	5.7 mA	5.7 mA	9 mA / 5 mA	2.7 mA
<b>Ordering data Complete module</b>				
CO contact Type	MCZ R 24VDC	MCZ R 24VDC 5uAu	MCZ R 24VUC	MCZ R 60VDC
Order No.	<b>8365980000</b>	<b>8442960000</b>	<b>8390590000</b>	<b>8470380000</b>
NO contact Type				
Order No.				
<b>Ordering data Spare relay</b>				
Type				
Order No.				
<b>Note</b>		Safely switches loads of: 100 mV...60 V AC/DC, 1 mA...300 mA. The gold layer may be destroyed by switching greater voltages.		
<b>Ordering data</b>	<b>110 V DC 1CO</b>	<b>120 V AC 1CO</b>	<b>230 V AC 1CO</b>	
<b>Input</b>				
Rated voltage	110 V DC ±10%	120 V AC -15 %/ +10 %	230 V AC ±10%	
Rated current AC		7 mA	9.5 mA	
Rated current DC	2.85 mA			
Power rating	340 mW	0.85 VA	2.1 VA	
AC Response/dropout Volt		approx. 70 V/approx. 22 V	approx. 115 V/approx. 60 V	
DC Response/dropout Volt	approx. 68 V/approx. 19 V			
AC pickup/dropout current		4 mA / 1,3 mA	5 mA / 2,5 mA	
DC pickup/dropout current	1.6 mA/0.4 mA			
<b>Ordering data Complete module</b>				
CO contact Type	MCZ R 110VDC	MCZ R 120VAC	MCZ R 230VAC	
Order No.	<b>8467470000</b>	<b>8420880000</b>	<b>8237710000</b>	
NO contact Type				
Order No.				
<b>Ordering data Spare relay</b>				
Type				
Order No.				
<b>Note</b>				

**Relays - MCZ-TRAK-SERIES**

**MCZ R TRAK**  
**1 CO contact or 1 NO contact**  
**DC coil**

- 1 change-over contact, also with gold contacts
- Module for rail industry applications
- Vibration requirements to EN 61373, requirements category 1 class B
- Voltage fluctuations -30%/+25% and ±40% for 0.1 s
- Voltage interruptions at input up to 10 ms
- Condensation permissible

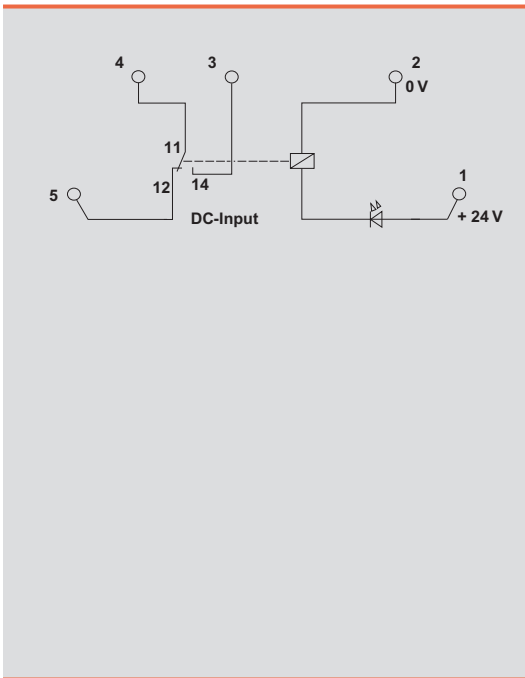

Output		
max. switching voltage AC1/Continuous current	250 V/6 A	
min. switching power	5 V / 10 mA	
Response time / Drop-out time	< 6,5 ms / < 75 ms	
Contact base material	AgSnO	
Mechanical endurance	20*10 <sup>6</sup> switching cycles	
max. switching frequency at rated load	0.1 Hz	
Rated data		
Status indicator/Free wheel diode	green LED/Yes	
Reverse pol. prot	available	
Operating temperature	+85°C for 10 minutes; -25 °C...+70 °C	
Storage temperature	-40 °C...+85 °C	
Humidity	95% for 30 days, slight condensation as per EN 50155	
Approvals	CE;	
Insulation coordination (EN 50178)		
Standards	EN 50178	
Rated voltage	300 V	
Impulse withstand voltage	4 kV (1.2/50 µs)	
Creepage and clearance path input - output	≥ 5.5 mm	
Surge category	III	
Pollution severity	2	
Protective separation to VDE 0106 part 101	yes	
Dimensions		
Clamping range (rating- / min. / max.)	mm <sup>2</sup>	1.5 / 0.5 / 2.5
Length x width x height	mm	91 / 6 / 63.2
<b>Note</b>	End plate AP MCZ 1.5: 8389030000 for cross-connectors and markers see MCZ Series accessories	

**Applications**

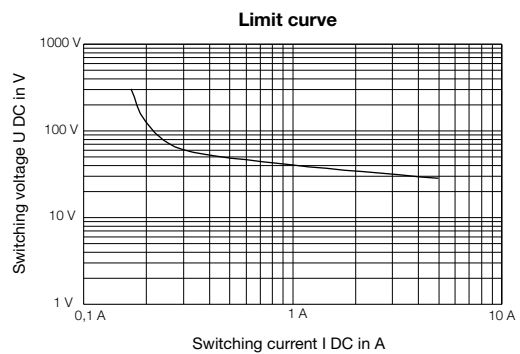
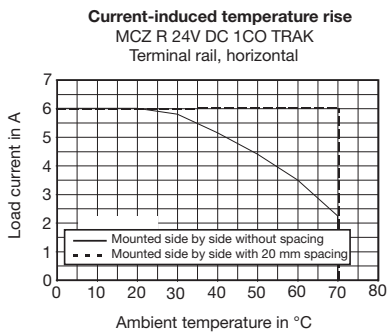

**MCZ R TRAK**  
**1 CO contact or 1 NO contact**  
**DC coil**

Ordering data	24 V DC TRAK	36 V DC TRAK	48...110 V DC TRAK	
<b>Input</b>				
Rated voltage	24 V DC	36 V DC	48...110 V DC TRAK	
Rated current AC				
Rated current DC	11.5...16.5 V	8...12 mA	< 3 mA	
Power rating	195...50 mW	200...540 mW	< 300 mW	
AC Response/dropout Volt				
DC Response/dropout Volt	7...14 V / 3...5 V	4.5...15 V	> 25 V / < 6 V	
AC pickup/dropout current				
DC pickup/dropout current				
<b>Ordering data Complete module</b>				
CO contact	MCZ R 24Vdc 1CO TRAK	MCZ R 36Vdc 1CO TRAK	MCZ R 48...110Vdc 1CO TRAK	
Type				
Order No.	<b>8713890000</b>	<b>8713900000</b>	<b>8713910000</b>	
NO contact	MCZ R 24Vdc 1NO TRAK	MCZ R 36Vdc 1NO TRAK	MCZ R 48...110Vdc 1NO TRAK	
Type				
Order No.	<b>8499550000</b>	<b>8582130000</b>	<b>8574070000</b>	
<b>Ordering data Spare relay</b>				
Type				
Order No.				
<b>Note</b>				

Ordering data	24 V DC TRAK Au	36 V DC TRAK Au	48...110 V DC TRAK Au	
<b>Input</b>				
Rated voltage	24 V DC	36 V DC	48...110 V DC TRAK	
Rated current AC				
Rated current DC	11.5...16.5 mA	8...12 mA	< 3 mA	
Power rating	195...50 mW	200...540 mW	< 300 mW	
AC Response/dropout Volt				
DC Response/dropout Volt	7...14 V / 3...5 V	4.5...15 V	> 25 V / < 6 V	
AC pickup/dropout current				
DC pickup/dropout current				
<b>Ordering data Complete module</b>				
CO contact	MCZ R 24VDC 1CO AU TRAK	MCZ R 36VDC 1CO AU TRAK	MCZ R 48...110VDC 1CO AU	
Type				
Order No.	<b>8790520000</b>	<b>8790510000</b>	<b>8790500000</b>	
NO contact				
Type				
Order No.				
<b>Ordering data Spare relay</b>				
Type				
Order No.				
<b>Note</b>	Safely switches loads of: 100 mV...60 V AC/DC, 1 mA...300 mA. The gold layer may be destroyed by switching greater voltages.	Safely switches loads of: 100 mV...60 V AC/DC, 1 mA...300 mA. The gold layer may be destroyed by switching greater voltages.	Safely switches loads of: 100 mV...60 V AC/DC, 1 mA...300 mA. The gold layer may be destroyed by switching greater voltages.	

Relays – MCZ-SERIES accessories

MCZ accessories

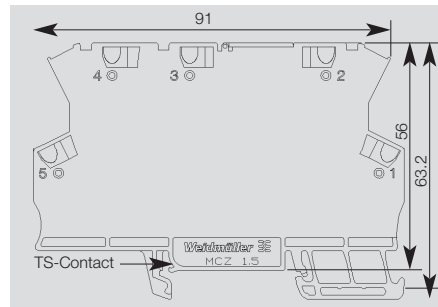

Ordering data

	Type	Qty	Order No.
End plate	AP MCZ 1.5	50	8389030000

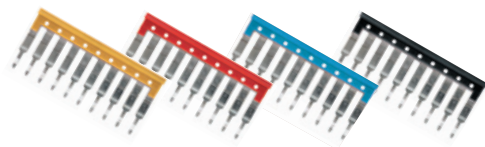

Ordering data

	No. of poles	Type	Qty	Order No.
Plug-in cross-connection, yellow	2	ZQV 4N / 2 GE	60	1758250000
Plug-in cross-connection, yellow	3	ZQV 4N / 3 GE	60	1762630000
Plug-in cross-connection, yellow	4	ZQV 4N / 4 GE	60	1762620000
Plug-in cross-connection, yellow	10	ZQV 4N / 10 GE	20	1758260000
Plug-in cross-connection, yellow	20	ZQV 4N / 20 GE	20	1909020000
Plug-in cross-connection, red	2	ZQV 4N / 2 RT	60	1793950000
Plug-in cross-connection, red	3	ZQV 4N / 3 RT	60	1793980000
Plug-in cross-connection, red	4	ZQV 4N / 4 RT	60	1794010000
Plug-in cross-connection, red	10	ZQV 4N / 10 RT	20	1794040000
Plug-in cross-connection, red	20	ZQV 4N / 20 RT	20	1909150000
Plug-in cross-connection, blue	2	ZQV 4N / 2 BL	60	1793960000
Plug-in cross-connection, blue	3	ZQV 4N / 3 BL	60	1793990000
Plug-in cross-connection, blue	4	ZQV 4N / 4 BL	60	1794020000
Plug-in cross-connection, blue	10	ZQV 4N / 10 BL	20	1794050000
Plug-in cross-connection, blue	20	ZQV 4N / 20 BL	20	1909100000
Plug-in cross-connection, black	2	ZQV 4N / 2 SW	60	1793970000
Plug-in cross-connection, black	3	ZQV 4N / 3 SW	60	1794000000
Plug-in cross-connection, black	4	ZQV 4N / 4 SW	60	1794030000
Plug-in cross-connection, black	10	ZQV 4N / 10 SW	20	1794060000
Plug-in cross-connection, black	20	ZQV 4N / 20 SW	20	1909120000



Ordering data

	Type	Qty	Order No.
Marker	WS10/6	200	1060960000



**Relays - MICROSERIES**

**1 change-over contact  
AC/DC/UC coil**

Module can be used as an universal interface between the controller and the actuator to switch small and medium-sized loads.

- Relay modul interchangeable, also for an opto modul
- 6.1 mm wide
- Pluggable cross-connection at input and output minimises the wiring workload.

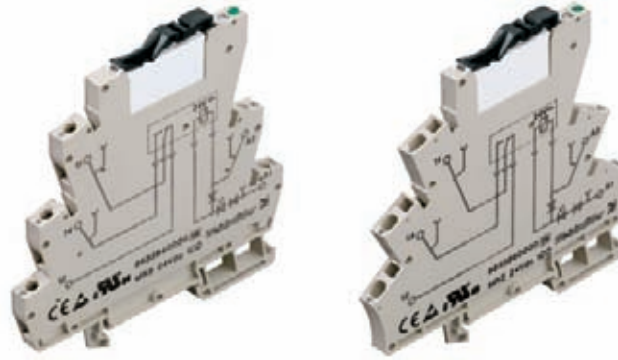

**C**

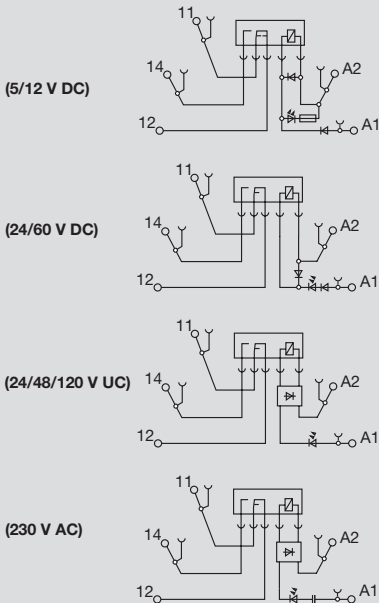

Output			
max. switching voltage AC1/Continuous current	250 V/6 A		
min. switching power	5 V / 10 mA		
Response time / Drop-out time	6.2ms/3.9ms		
Contact base material	AgSnO		
Mechanical endurance	20*10 <sup>6</sup> switching cycles		
max. switching frequency at rated load	0.1 Hz		
Rated data			
Status indicator/Free wheel diode	green LED/Yes		
Reverse pol. prot	available		
Operating temperature	-25 °C...+50 °C		
Storage temperature	-40 °C...+60 °C		
Humidity	40°C/93% RH, no condensation		
Approvals	CE; cULus;		
Insulation coordination (EN 50178)			
Standards	EN 50178		
Rated voltage	300 V		
Impulse withstand voltage	4 kV		
Creepage and clearance path input - output	≥ 5.5 mm		
Surge category	III		
Pollution severity	2		
Protective separation to VDE 0106 part 101	yes		
Dimensions		Screw connection	Tension clamp connection
Clamping range (rating- / min. / max.)	mm <sup>2</sup>	2.5 / 0.5 / 4	1.5 / 0.5 / 2.5
Length x width x height	mm	93 / 6.1 / 92	94 / 6.1 / 91
<b>Note</b>		Cross-connectors and markers - see MICROSERIES accessories	

**Applications**

**Limit curve**

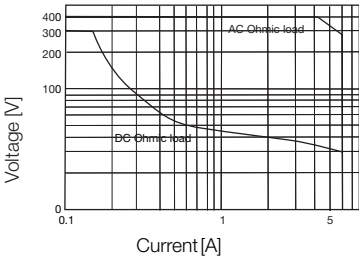

**Current-Temperature rise curve**

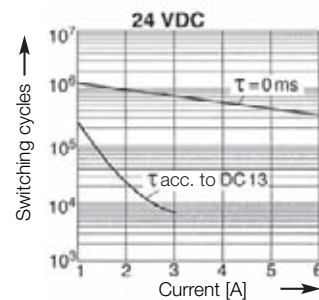
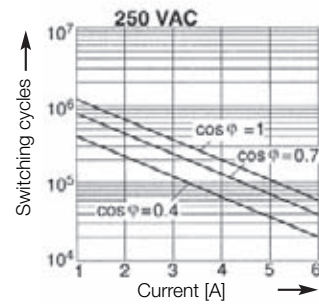
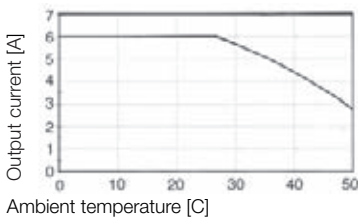

**1 change-over contact  
AC/DC/UC coil**

Ordering data	5 V DC 1CO	12 VDC 1CO	24 V DC 1CO	24 V UC 1CO
<b>Input</b>				
Rated voltage	5 V DC ±20%	5 V DC ±20%	24 V DC ±20 %	24 V UC ±10 %
Rated current AC				11 mA
Rated current DC	38.5 mA	17 mA	6.6mA	6.4 mA
Power rating	193 mW	210 mW	160 mW	154 mW
AC Response/dropout Volt				15.8V/7V
DC Response/dropout Volt	3.2V/1.6V	6.4V/ 2.5V	15.4V/6.5V	15.8V/7V
AC pickup/dropout current				3.6mA/1.3mA
DC pickup/dropout current	21.6mA/8mA	8.4mA/2.4mA	4mA/1.2mA	3.6mA/1.3mA
<b>Ordering data Complete module</b>				
Screw connection Type	MRS 5Vdc 1CO	MRS 12Vdc 1CO	MRS 24Vdc 1CO	MRS 24Vuc 1CO
Order No.	<b>8556080000</b>	<b>8556070000</b>	<b>8533640000</b>	<b>8556050000</b>
Tension spring connection Type	MRZ 5Vdc 1CO	MRZ 12Vdc 1CO	MRZ 24VDC 1CO	MRZ 24Vuc 1CO
Order No.	<b>8556150000</b>	<b>8556140000</b>	<b>8533660000</b>	<b>8556120000</b>
<b>Ordering data Spare relay (pluggable)</b>				
Type	RSS113005 05Vdc-Rel1U	RSS113012 12Vdc-Rel1U	RSS113024 24Vdc-Rel1U	RSS113024 24Vdc-Rel1U
Order No.	<b>4061580000</b>	<b>4061610000</b>	<b>4060120000</b>	<b>4060120000</b>
<b>Note</b>				
<b>Ordering data</b>	<b>48 V UC 1CO</b>	<b>60 V DC 1CO</b>	<b>120 V UC 1CO</b>	<b>230 V AC 1CO</b>
<b>Input</b>				
Rated voltage	48 V UC ±10 %	5 V DC ±20%	120 V UC + 10 %/ -15 %	230 V AC ±10%
Rated current AC	5 mA		3.5 mA	7.6 mA
Rated current DC	4 mA	3.3 mA	3.5 mA	
Power rating	190 mW	200 mW	0.42 VA	1.75 VA
AC Response/dropout Volt	29V/11V		71V/22V	103V/49V
DC Response/dropout Volt	29V/11V	35V/11V	71V/22V	
AC pickup/dropout current	2.2mA/1.3mA		1.8mA/0.5mA	5mA/2.5mA
DC pickup/dropout current	2.2mA/1.3mA	1.6mA/0.6mA	1.8mA/0.5mA	
<b>Ordering data Complete module</b>				
Screw connection Type	MRS 48Vuc 1CO	MRS 60Vdc 1CO	MRS 120Vuc 1CO	MRS 230Vac 1CO
Order No.	<b>8556040000</b>	<b>8556060000</b>	<b>8556030000</b>	<b>8556020000</b>
Tension spring connection Type	MRZ 48Vuc 1CO	MRZ 60Vdc 1CO	MRZ 120Vuc 1CO	MRZ 230Vac 1CO
Order No.	<b>8556110000</b>	<b>8556130000</b>	<b>8556100000</b>	<b>8556090000</b>
<b>Ordering data Spare relay (pluggable)</b>				
Type	RSS113048 48Vdc-Rel1U	RSS113060 60Vdc-Rel1U	RSS113060 60Vdc-Rel1U	RSS113024 24Vdc-Rel1U
Order No.	<b>4061620000</b>	<b>4061630000</b>	<b>4061630000</b>	<b>4060120000</b>
<b>Note</b>				

## Relays - MICROSERIES

### 1 NO contact special versions

- 24 V DC actuator version:  
Bridgeable, floating connection for direct connection of actuators at the output
- 120 V AC RC version:  
RC circuit at the input guarantees safe switching thresholds, e.g. for leakage currents on the control side

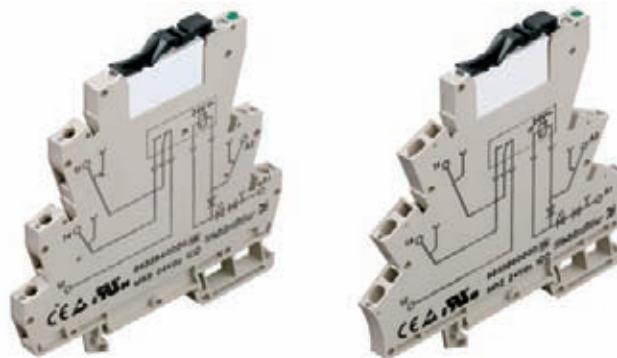

C

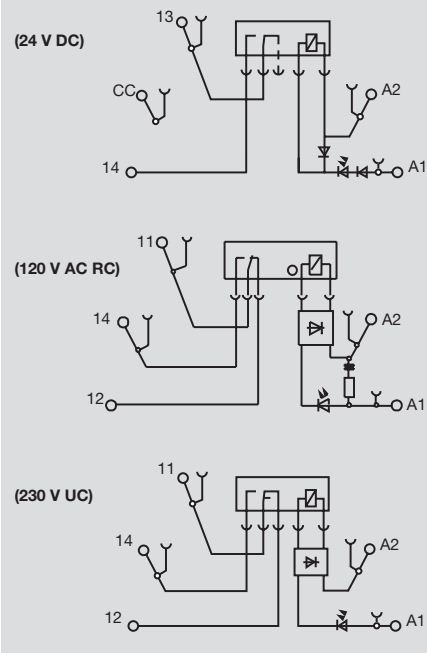

Output	
max. switching voltage AC1/Continuous current	250 V/6 A
min. switching power	5 V / 10 mA
Response time / Drop-out time	6.6 ms/5.8 ms
Contact base material	AgSnO
Mechanical endurance	20*10 <sup>6</sup> switching cycles
max. switching frequency at rated load	0.1 Hz
Rated data	
Status indicator/Free wheel diode	green LED/Yes
Reverse pol. prot	available
Operating temperature	-25 °C...+ 55 °C
Storage temperature	-40 °C...+60 °C
Humidity	40°C/93% RH, no condensation
Approvals	CE; cULus;
Insulation coordination (EN 50178)	
Standards	EN 50178
Rated voltage	300 V
Impulse withstand voltage	4 kV (1.2/50 µs)
Creepage and clearance path input - output	≥ 5.5 mm
Surge category	III
Pollution severity	2
Protective separation to VDE 0106 part 101	
Dimensions	
Clamping range (rating- / min. / max.)	mm <sup>2</sup> 2.5 / 0.5 / 4
Length x width x height	mm 93 / 6.1 / 92
<b>Note</b>	Cross-connectors and markers - see MICROSERIES accessories

### Ordering data

Input	24 V DC ACT	120 V AC 1CO RC	230 V UC 1CO	
Rated voltage	24 V DC ±20 %	120 V AC + 10 %/ -15 %	230 V UC +10 % / -15 %	
Rated current AC		7 mA	3.5 mA	
Rated current DC	6.6 mA		2.9 mA	
Power rating	160 mW	0.84 VA	0.8 VA / 660 mW	
AC Response/dropout Volt		79 V / 65 V	146 V / 124 V	
DC Response/dropout Volt	15,4 V / 6,5 V		155 V / 115 V	
AC pickup/dropout current		4.5 mA / 3.7 mA	1.9 mA / 1.5 mA	
DC pickup/dropout current	4 mA / 1,2 mA		1.9 mA / 1.0 mA	

Ordering data Complete module				
Screw connection Type	MRS 24Vdc ACT	MRS 120VUC 1CO RC	MRS 230VUC 1CO	
Order No.	<b>8660920000</b>	<b>8825970000</b>	<b>8825990000</b>	
Tension clamp connection Type	MRZ 24VDC ACT	MRZ 120VUC 1CO RC	MRZ 230VUC 1CO	
Order No.	<b>8660910000</b>	<b>8825960000</b>	<b>8825980000</b>	

Ordering data Spare relay, pluggable				
Type	RSS113024 24Vdc-Rel1U	RSS113060 60Vdc-Rel1U	RSS113060 60Vdc-Rel1U	
Order No.	<b>4060120000</b>	<b>4061630000</b>	<b>4061630000</b>	

Note				

**1 change-over contact with gold-plated contact AC/DC/UC coil**

Module can be used as an universal interface between the controller and the actuator to switch small and medium-sized loads.

- Relay modul interchangeable, also for an opto modul
- 6.1 mm wide
- Pluggable cross-connection at input and output minimises the wiring workload.

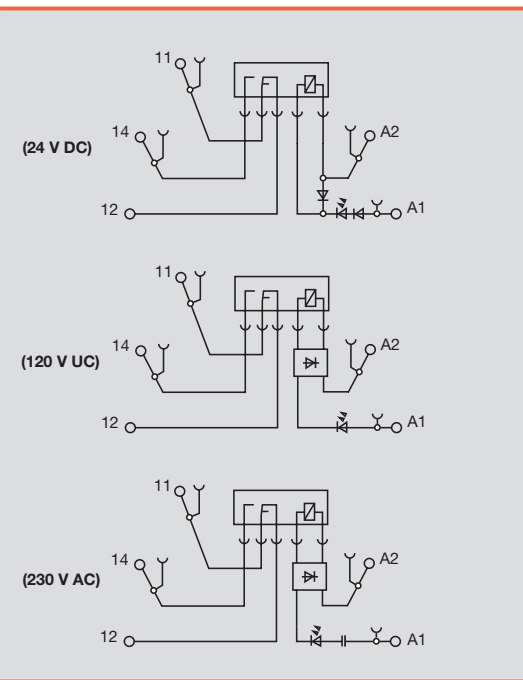
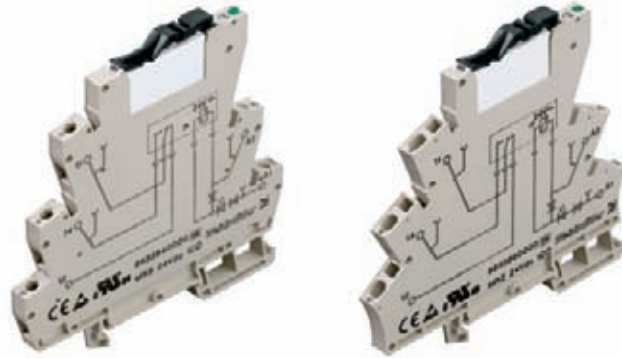

Output	
max. switching voltage AC1/Continuous current	250 V/6 A
min. switching power	1 V / 1 mA
Response time / Drop-out time	6.6ms/5.8ms
Contact base material	AgSnO 5µm Au
Mechanical endurance	20*10 <sup>6</sup> switching cycles
max. switching frequency at rated load	0.1 Hz
Rated data	
Status indicator/Free wheel diode	green LED/Yes
Reverse pol. prot	available
Operating temperature	-25 °C...+50 °C
Storage temperature	-40 °C...+60 °C
Humidity	40°C/93% RH, no condensation
Approvals	CE; cULus;
Insulation coordination (EN 50178)	
Standards	EN 50178
Rated voltage	300 V
Impulse withstand voltage	4 kV
Creepage and clearance path input - output	≥ 5.5 mm
Surge category	III
Pollution severity	2
Protective separation to VDE 0106 part 101	yes
Dimensions	
Clamping range (rating- / min. / max.)	mm <sup>2</sup> 2.5 / 0.5 / 4
Length x width x height	mm 93 / 6.1 / 92
Note	
Cross-connectors and markers - see MICROSERIES accessories	

**Ordering data**

Input	24 V DC 1CO Au	120 V UC 1CO Au	230 V AC 1CO Au	
Rated voltage	24 V DC ±20 %	120 V UC + 10 %/ -15 %	230 V AC ±10%	
Rated current AC		3.5mA ±15%	7.6mA	
Rated current DC	6.6 mA	3.5mA ±15%		
Power rating	160 mW	0.42 VA ±15%	1.75VA	
AC Response/dropout Volt		71 V/ 22 V	103V/49V	
DC Response/dropout Volt	15.4V/6.5V	71 V/ 22 V		
AC pickup/dropout current		1.8 mA/0.5 mA	5mA/2.5mA	
DC pickup/dropout current	4mA/1.2mA	1.8mA/0.5mA		

**Ordering data Complete module**

Screw connection	Type	24 V DC 1CO Au	120 V UC 1CO Au	230 V AC 1CO Au	
Order No.		MRS 24Vdc 1CO 5uAu	MRS 120Vuc 1CO 5uAu	MRS 230Vac 1CO 5uAu	
		<b>8596060000</b>	<b>8652030000</b>	<b>8596050000</b>	
Tension clamp connection	Type	24 V DC 1CO Au	120 V UC 1CO Au	230 V AC 1CO Au	
Order No.		MRZ 24Vdc 1CO 5uAu	MRZ 120Vuc 1CO 5uAu	MRZ 230Vac 1CO 5uAu	
		<b>8596080000</b>	<b>8652040000</b>	<b>8596070000</b>	

**Ordering data Spare relay, pluggable**

Type	24 V DC 1CO Au	120 V UC 1CO Au	230 V AC 1CO Au	
Order No.	RSS112024 24Vdc-Rel1U	RSS112060 60Vdc-Rel1U	RSS112024 24Vdc-Rel1U	
	<b>4061590000</b>	<b>4061600000</b>	<b>4061590000</b>	

Note	24 V DC 1CO Au	120 V UC 1CO Au	230 V AC 1CO Au	
	Safely switches loads of: 100 mV...60 V AC/DC, 1 mA...300 mA. The gold layer may be destroyed by switching greater voltages.	Safely switches loads of: 100 mV...60 V AC/DC, 1 mA...300 mA. The gold layer may be destroyed by switching greater voltages.	Safely switches loads of: 100 mV...60 V AC/DC, 1 mA...300 mA. The gold layer may be destroyed by switching greater voltages.	

Relays - MICROSERIES

RSS Relays  
1 change-over contact DC coil



C

Contact life expectancy,  
material AgSnO<sub>2</sub>

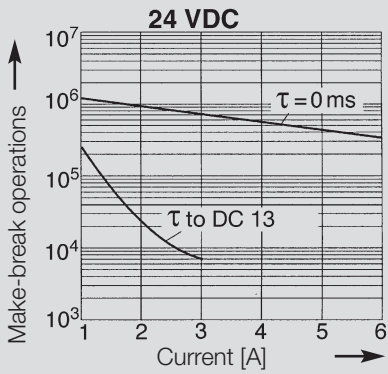
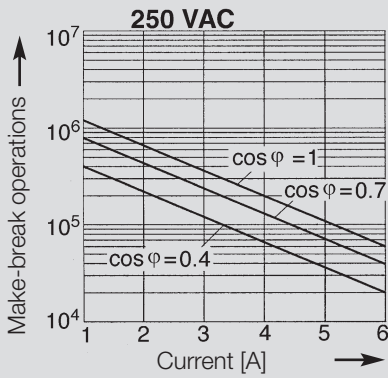

Dimensions

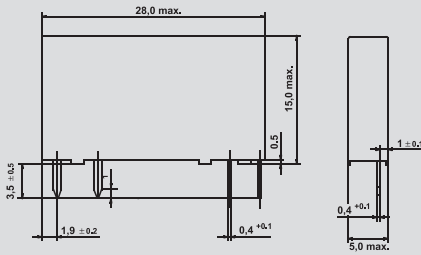

Technical data

Number of contacts and type	1 change-over contact
Contact form	single
Switching current	6 A
Switching voltage / max. switching voltage	250 V AC / 400 V AC
Switching capacity	1500 VA
Contact material / recommended min. load	AgSnO <sub>2</sub> 12 V, 10 mA AgSnO <sub>2</sub> 5μ Au 1 V, 1 mA <sup>1)</sup>
Typical bounce time, NOC	1 ms
Typical bounce time, NCC	5 ms
<b>Other data</b>	
UL 94 flammability rating	V-0
Ambient temperature	-40 ... +85 °C
Max. switching frequency at nom. load / without load	6/1200 make-break operations per minute
Pick-up / drop-out time	5 / 2.5 ms
Bounce time, NOC / NCC	1.5 / 5 ms
Ingress protection class housing	IP 67

<sup>1)</sup> Recommended switching capacity: μW up to 0.25 W (depends on load characteristics), at 2.5 W the silver coating remains effective for about 20 000 make-break operations.

Ordering data

	Type	Qty	Order No.
Coil voltage 5 V, 1 change-over contact	RSS 113005	20	4061580000
Coil voltage 12 V, 1 change-over contact	RSS 113012	20	4061610000
Coil voltage 24 V, 1 change-over contact	RSS 113024	20	4060120000
Coil voltage 48 V, 1 change-over contact	RSS 113048	20	4061620000
Coil voltage 60 V, 1 change-over contact	RSS 113060	20	4061630000
Coil voltage 24 V, 1 change-over contact, 5μ Au <sup>1)</sup>	RSS 112024	20	4061590000
Coil voltage 60 V, 1 change-over contact, 5μ Au <sup>1)</sup>	RSS 112060	20	4061600000

Type code for RSS relays

Type code	RSS				
Type	RIDER Signal Slim				
Model	1 Printing, vertical, washable				
Type of contact	1 1 Changeover contact				
Contact material	2 AgSnO <sub>2</sub> htv 3 AgSnO <sub>2</sub>				
Coil	005	5 V DC			
	012	12 V DC			
	024	24 V DC			
	048	48 V DC			
	060	60 V DC			

Accessories

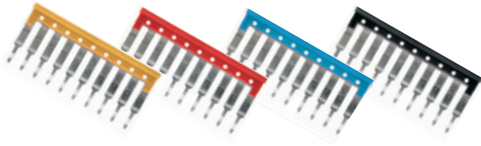

Plug-in cross-connection

Type	No. of poles	Qty	Order No.
<b>yellow</b>			
ZQV 4N / 2 GE	2	60	1758250000
ZQV 4N / 3 GE	3	60	1762630000
ZQV 4N / 4 GE	4	60	1762620000
ZQV 4N / 10 GE	10	20	1758260000
ZQV 4N / 20 GE	20	20	1909020000
<b>red</b>			
ZQV 4N / 2 RT	2	60	1793950000
ZQV 4N / 3 RT	3	60	1793980000
ZQV 4N / 4 RT	4	60	1794010000
ZQV 4N / 10 RT	10	20	1794040000
ZQV 4N / 20 RT	20	20	1909150000
<b>blue</b>			
ZQV 4N / 2 BL	2	60	1793960000
ZQV 4N / 3 BL	3	60	1793990000
ZQV 4N / 4 BL	4	60	1794020000
ZQV 4N / 10 BL	10	20	1794050000
ZQV 4N / 20 BL	20	20	1909100000
<b>black</b>			
ZQV 4N / 2 SW	2	60	1793970000
ZQV 4N / 3 SW	3	60	1794000000
ZQV 4N / 4 SW	4	60	1794030000
ZQV 4N / 10 SW	10	20	1794060000
ZQV 4N / 20 SW	20	20	1909120000

General data – MICROSERIES

Technical data

Conductor		Tension spring connection	Screw connection
Solid H07V-U	mm <sup>2</sup>	0.5 ... 2.5	0.5 ... 4.0
Stranded H07V-K	mm <sup>2</sup>	0.5 ... 2.5	0.5 ... 2.5
"f" with wire end ferrules to DIN 46228-1	mm <sup>2</sup>	0.5 ... 1.5	0.5 ... 1.5
"f" with wire end ferrules with plastic collar	mm <sup>2</sup>	0.5 ... 1.5	0.5 ... 1.5
Max. clamping range	mm <sup>2</sup>	0.13 ... 2.5	0.13 ... 4.0
Plug gauge to IEC 60947-1	size	A 2	A 3

  

General technical data			
Nominal torque		-	0.6
Continuous current for 2-pole cross-connection	A	10	10
Continuous current for multi-pole cross-connection	A	10	10
Stripping length	mm	10	7
Ingress protection class		IP 20	IP 20
Housing material		Wemid	Wemid
UL 94 flammability rating		V-0	V-0
Nominal current	A	6	6
Nominal voltage	V	250	250

Other accessories

Type		Qty	Order No.
<b>Base only</b>			
MXZ 24VDC 1CO BASIS		10	8826000000
MXS 24VDC 1CO BASIS		10	8826010000
MXZ 120VUC 1CO BASIS		10	8826020000
MXS 120VUC 1CO BASIS		10	8826030000
MXZ 230VAC 1CO BASIS		10	8826040000
MXS 230VAC 1CO BASIS		10	8826050000
<b>Markers</b>			
WS 12/6	12 x 6 mm	200	1061160000
<b>Labels, Lasermark</b>			
LM MT 300 15/6 ge	484 labels/sheet	10	1686360000
<b>Screwdriver</b>			
SD 0.6 x 3.5 x 100		10	9008330000

Dimensions

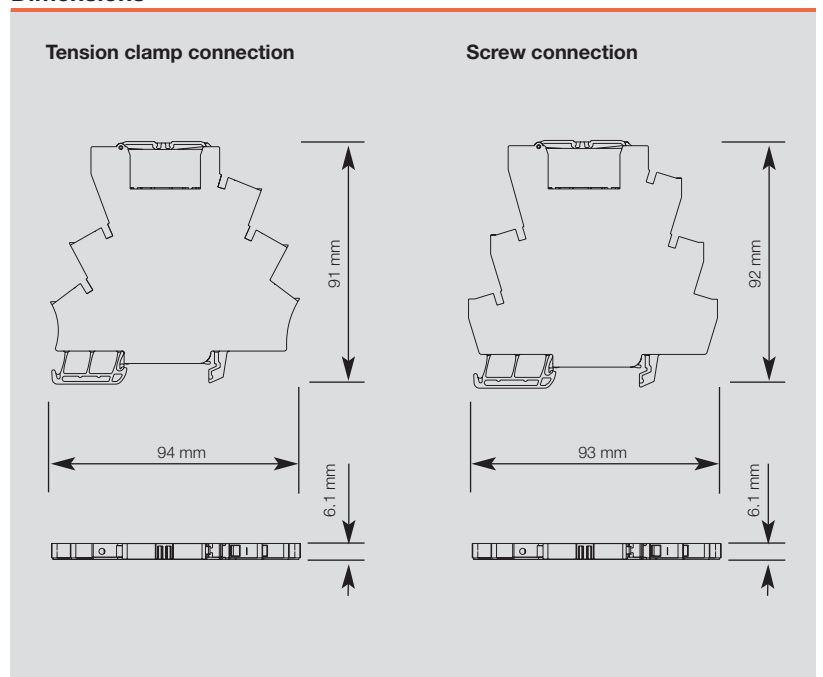

# MICROinterface Digital

Link field and control with a system instead of masses of wires.

MICROinterface Digital is the answer to connecting eight MICROSERIES couplers to a PLC I/O module via pre-assembled lines. It results in simple, error-free connections between field and control.

First, set up a block of eight couplers using Weidmüller's well-known relays or optos from the MICROSERIES range (available with screw or tension clamp connections). Plug the interface module into the corresponding cross-connection openings using a ribbon cable or SUB-D connection. Using the pre-assembled cables available in various lengths, simply connect to the main PLC.

## Features

- No tools required for installation
- Compatible with MICROSERIES screw and tension clamp connections
- Electrical isolation and signal adaptation with relays or optos as required

### MICROinterface module for ribbon cable connection



### MICROinterface module for SUB-D connection



MICROinterface digital

MI8DI-S/Z

MI8DO-S/Z

Input module

Output module

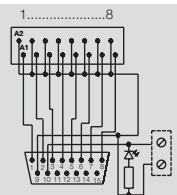
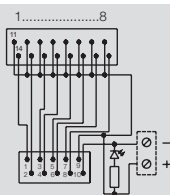

Technical data

Connection data

Type  
Type of terminal / Connection system

Input module  
MICRO series;Screw or tension clamp connection;available for ribbon cable or Sub-D connection

Output module  
MICRO series;Screw or tension clamp connection;available for ribbon cable or Sub-D connection

Rated data

Operating voltage, max.  
Current-carrying capacity  
Total current feed, max.  
Impulse withstand voltage (1.2/50 µs)  
Rated insulation voltage  
Storage temperature  
Operating temperature

30 V AC/DC  
0.5 A per channel  
2 A  
330 V  
32 V  
-20 °C...+85 °C  
0 °C...+55 °C

30 V AC/DC  
0.5 A per channel  
2 A  
330 V  
32 V  
-20 °C...+85 °C  
0 °C...+55 °C

Insulation coordination (EN 50 178)

Surge category  
Pollution severity  
Clearances/Creepage distances to EN

I  
2  
0.1 mm

I  
2  
0.1 mm

Clamping range (rating- / min. / max.) mm<sup>2</sup>  
Length x width x height mm

x —

x —

Note

Wiring diagram for ribbon cable

Wiring diagram for SUB-D

Ordering data

Connection system, pre-assembled cable
Ribbon cable connector, 10-pole
SUB-D plug, 15-pole
Ribbon cable connector, 10-pole
SUB-D plug, 15-pole

Type	Qty	Order No.
MI8DI-S F10 S	1	8773510000
MI8DI-S SUB D15S	1	8773460000
MI8DI-Z F10 S	1	8773530000
MI8DI-Z SUB D15S	1	8773490000

Type	Qty	Order No.
MI8DO-S F10 S	1	8773600000
MI8DO-S SUB D15S	1	8773550000
MI8DO-Z F10 S	1	8773620000
MI8DO-Z SUB D15S	1	8773570000

Note

MI8DI-S = Screw connection  
MI8DI-Z = Tension clamp connection

MI8DI-S = Screw connection  
MI8DI-Z = Tension clamp connection

Accessories

Note

## Relays - PLUGSERIES

### 1 change-over contact AC/DC coil

- Modular system comprising
- relay socket for rail mounting
  - LED indicator unit
  - Retaining clip
  - plug-in relay

cross-section of coil connections  
and relay changeover contacts by means of  
plug-in cross-connection ZQV 2.5N

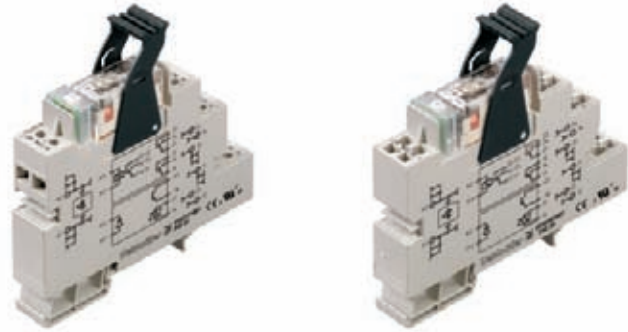

C

#### DC version

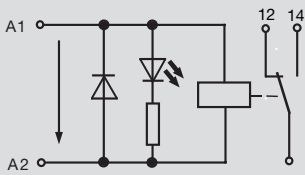

#### AC version

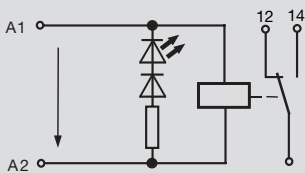

#### Output

max. switching voltage AC1/Continuous current	250 V/16 A
min. switching power	10 V / 100 mA
Response time / Drop-out time	5.8ms/6.9ms
Contact base material	AgNi 90/10
Mechanical endurance	30*10 <sup>6</sup> switching cycles
max. switching frequency at rated load	0.1 Hz

#### Rated data

Status indicator/Free wheel diode	green LED/Yes
Reverse pol. prot	No
Operating temperature	-40 °C...+50 °C
Storage temperature	-40 °C...+ 50 °C
Humidity	40°C/93% RH, no condensation
Approvals	CE;cURus;CSA;

#### Insulation coordination (EN 50178)

Standards	EN 50178
Rated voltage	250 V
Impulse withstand voltage	6 kV
Creepage and clearance path input - output	> 8 mm
Surge category	III
Pollution severity	2
Protective separation to VDE 0106 part 101	yes

#### Dimensions

Clamping range (rating- / min. / max.)	mm <sup>2</sup>
Length x width x height	mm

#### Screw connection

2.5 / 0.5 / 2.5
92 / 15.3 / 95

#### Tension clamp connection

2.5 / 0.5 / 2.5
92 / 15.3 / 87

#### Note

Cross-connectors and markers - see PLUGSERIES accessories

## Applications

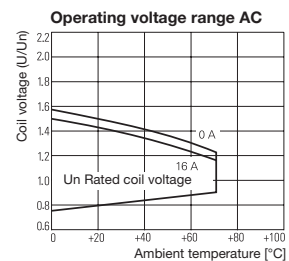
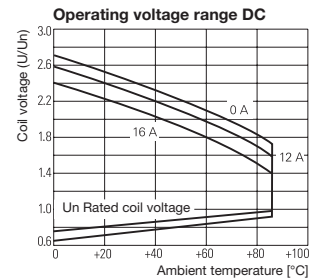
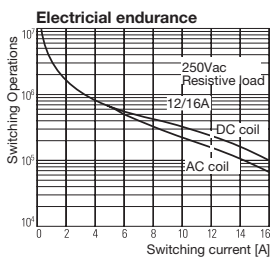
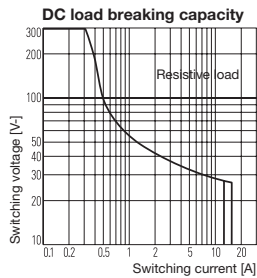

1 change-over contact  
AC/DC coil

C

Ordering data	12 V DC 1CO	24 V DC 1CO	115 V DC 1CO	24 V AC 1CO
<b>Input</b>				
Rated voltage	5 V DC ±20%	24 V DC ±10%	115 V DC ±10 %	24 V AC ±10 %
Rated current AC				32 mA
Rated current DC	33 mA	16 mA	3.5 mA	
Power rating	400 mW	400 mW	400 mW	0.75 VA
AC Response/dropout Volt				17V/3.6V
DC Response/dropout Volt	8.4V/1.2V	16.8 V / 2.4 V	76 V / 11 V	
<b>Ordering data Complete module</b>				
Screw connection Type	PRS 12Vdc LD 1CO	PRS 24Vdc LD 1CO	PRS 115Vdc LD 1CO	PRS 24Vac LD 1CO
Order No.	<b>8536471001</b>	<b>8530621001</b>	<b>8536510000</b>	<b>8536530000</b>
Tension spring connection Type	PRZ 12Vdc LD 1CO	PRZ 24Vdc LD 1CO	PRZ 115Vdc LD 1CO	PRZ 24Vac LD 1CO
Order No.	<b>8536571001</b>	<b>8530691001</b>	<b>8536610000</b>	<b>8536651001</b>
<b>Ordering data Spare relay (pluggable)</b>				
Type	RCL314012	RCL314024	RCL314110	RCL314524
Order No.	<b>8693240000</b>	<b>8693260000</b>	<b>8821910000</b>	<b>8693500000</b>
<b>Note</b>				

Ordering data	120 V AC 1CO	230 V AC 1CO		
<b>Input</b>				
Rated voltage	120 V AC ±10 %	230 V AC ±10%		
Rated current AC	6.6 mA	3.2 mA		
Rated current DC				
Power rating	0.75 VA	0.75 VA		
AC Response/dropout Volt	86.3 V/ 17.3 V	171 V / 34 V		
DC Response/dropout Volt				
<b>Ordering data Complete module</b>				
Screw connection Type	PRS 120Vac LD 1CO	PRS 230Vac LD 1CO		
Order No.	<b>8530641001</b>	<b>8530671001</b>		
Tension spring connection Type	PRZ 120Vac LD 1CO	PRZ 230Vac LD 1CO		
Order No.	<b>8530710000</b>	<b>8530731001</b>		
<b>Ordering data Spare relay (pluggable)</b>				
Type	RCL314615	RCL314730		
Order No.	<b>8693890000</b>	<b>8693320000</b>		
<b>Note</b>				

## Relays - PLUGSERIES

### 2 change-over contacts AC/DC coil

- Modular system comprising
- relay socket for rail mounting
  - LED indicator unit
  - Retaining clip
  - plug-in relay

cross-section of coil connections  
and relay changeover contacts by means of  
plug-in cross-connection ZQV 2.5N



C

#### DC version

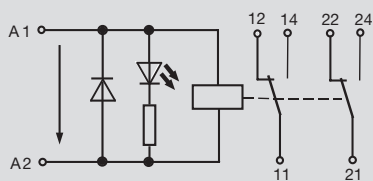

#### AC version

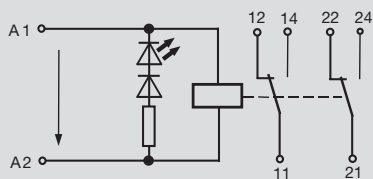

#### Output

max. switching voltage AC/Continuous current	250 V/8 A
min. switching power	10 V / 100 mA
Response time / Drop-out time	9ms/45ms
Contact base material	AgNi 90/10
Mechanical endurance	5*10 <sup>6</sup> switching cycles
max. switching frequency at rated load	0.1 Hz

#### Rated data

Status indicator/Free wheel diode	green LED/Yes
Reverse pol. prot	No
Operating temperature	-40 °C...+50 °C
Storage temperature	-40 °C...+ 50 °C
Humidity	40°C/93% RH, no condensation
Approvals	CE;cURus;CSA;

#### Insulation coordination (EN 50178)

Standards	EN 50178
Rated voltage	250 V
Impulse withstand voltage	6 kV
Creepage and clearance path input - output	> 8 mm
Surge category	III
Pollution severity	2
Protective separation to VDE 0106 part 101	yes

#### Dimensions

	Screw connection	Tension clamp connection
Clamping range (rating- / min. / max.)	mm <sup>2</sup> 2.5 / 0.5 / 2.5	2.5 / 0.5 / 2.5
Length x width x height	mm 92 / 15.3 / 95	92 / 15.3 / 87

#### Note

Cross-connectors and markers - see PLUGSERIES accessories

## Applications

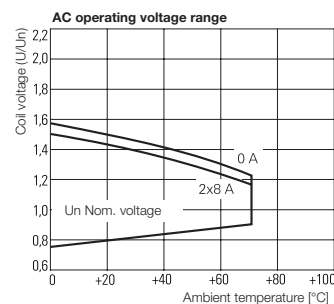
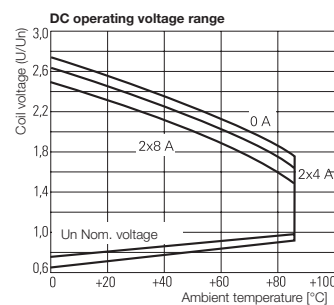
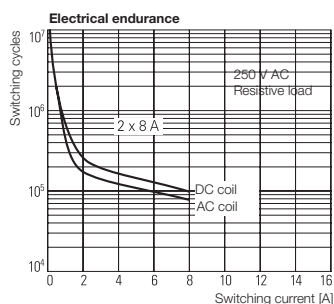
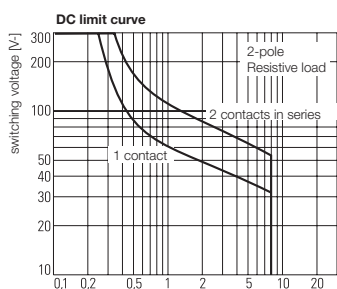

**2 change-over contacts  
AC/DC coil**

Ordering data	12 V DC 2CO	24 V DC 2CO	115 V DC 2CO	24 V AC 2CO
<b>Input</b>				
Rated voltage	5 V DC ±20%	24 V DC ±10%	115 V DC ±10 %	24 V AC ±10 %
Rated current AC				32 mA
Rated current DC	33 mA	16 mA	3.5 mA	
Power rating	400 mW	400 mW	400 mW	0.75 VA
AC Response/dropout Volt				17 V / 3.6 V
DC Response/dropout Volt	8.4 V / 1.2 V	16.8 V / 2.4 V	76 V / 11 V	
<b>Ordering data Complete module</b>				
Screw connection Type	PRS 12Vdc LD 2CO	PRS 24Vdc LD 2CO	PRS 115Vdc LD 2CO	PRS 24Vac LD 2CO
Order No.	<b>8536501001</b>	<b>8530631001</b>	<b>8536520000</b>	<b>8536560000</b>
Tension spring connection Type	PRZ 12Vdc LD 2CO	PRZ 24Vdc LD 2CO	PRZ 115Vdc LD 2CO	PRZ 24Vac LD 2CO
Order No.	<b>8536591001</b>	<b>8530701001</b>	<b>8536630000</b>	<b>8536681001</b>
<b>Ordering data Spare relay (pluggable)</b>				
Type	RCL 424012 12Vdc-Rel2U	RCL 424024 24Vdc-Rel2U	RCL 424110 110Vdc-Rel2U	RCL 424524 24Vac-Rel2U
Order No.	<b>4058560000</b>	<b>4058570000</b>	<b>4058590000</b>	<b>4058600000</b>
<b>Note</b>				
<b>Ordering data</b>	<b>120 V AC 2CO</b>	<b>230 V AC 2CO</b>		
<b>Input</b>				
Rated voltage	120 V AC ±10 %	230 V AC ±10%		
Rated current AC	6.6 mA	3.2 mA		
Rated current DC				
Power rating	0.75 VA	0.75 VA		
AC Response/dropout Volt	86.3 V/ 17.3 V	172.5 V/ 34.5 V		
DC Response/dropout Volt				
<b>Ordering data Complete module</b>				
Screw connection Type	PRS 120Vac LD 2CO	PRS 230Vac LD 2CO		
Order No.	<b>8530661001</b>	<b>8530681001</b>		
Tension spring connection Type	PRZ 120Vac LD 2CO	PRZ 230Vac LD 2CO		
Order No.	<b>8530720000</b>	<b>8530741001</b>		
<b>Ordering data Spare relay (pluggable)</b>				
Type	RCL 424615 115Vac-Rel2U	RCL 424730 230Vac-Rel2U		
Order No.	<b>4058610000</b>	<b>4058630000</b>		
<b>Note</b>				

## Relays - PLUGSERIES

### 2 change-over contacts with gold-plated contacts AC/DC coil

- Modular system comprising
- relay socket for rail mounting
  - LED indicator unit
  - Retaining clip
  - plug-in relay

cross-section of coil connections and relay changeover contacts by means of plug-in cross-connection ZQV 2.5N



C

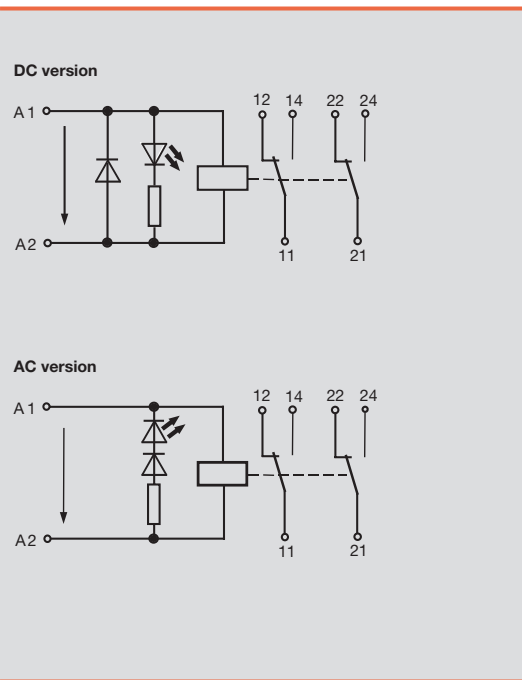

Output	
max. switching voltage AC1/Continuous current	250 V/8 A
min. switching power	5 V / 10 mA
Response time / Drop-out time	9ms/45ms
Contact base material	AgNi 5µm Au
Mechanical endurance	5*10 <sup>8</sup> switching cycles
max. switching frequency at rated load	0.1 Hz
Rated data	
Status indicator/Free wheel diode	green LED/no
Reverse pol. prot	No
Operating temperature	-40 °C...+50 °C
Storage temperature	-40 °C...+ 50 °C
Humidity	40°C/93% RH, no condensation
Approvals	CE;cURus;CSA;
Insulation coordination (EN 50178)	
Standards	EN 50178
Rated voltage	250 V
Impulse withstand voltage	6 kV
Creepage and clearance path input - output	> 8 mm
Surge category	III
Pollution severity	2
Protective separation to VDE 0106 part 101	yes
Dimensions	
Clamping range (rating- / min. / max.)	mm <sup>2</sup> 2.5 / 0.5 / 2.5
Length x width x height	mm 92 / 15.3 / 95
Note	
Cross-connectors and markers - see PLUGSERIES accessories	

Ordering data	24 V DC 2CO Au	120 V AC 2CO Au	230 V AC 2CO AU	
<b>Input</b>				
Rated voltage	24 V DC ±10%	120 V AC ±10 %	230 V AC ±10%	
Rated current AC		6.6 mA	3.2 mA	
Rated current DC	16 mA			
Power rating	400 mW	0.75 VA	0.75 VA	
AC Response/dropout Volt		86,3 V/ 17,3 V	172.5 V/ 34.5 V	
DC Response/dropout Volt	16.8 V / 2.4 V			
<b>Ordering data Complete module</b>				
Screw connection Type	PRS 24VDC LD 2COAU	PRS 120VAC LD 2CO AU	PRS 230VAC LD 2CO AU	
Order No.	<b>8561760000</b>	<b>8595960000</b>	<b>8595990000</b>	
Tension clamp connection Type	PRZ 24Vdc LD 2CO AU	PRZ 120VAC LD 2COAU	PRZ 230VAC LD 2COAU	
Order No.	<b>8552440000</b>	<b>8575940000</b>	<b>8575950000</b>	
<b>Ordering data Spare relay, pluggable</b>				
Type	RCL 425024 24Vdc-Rel2U	RCL 425615 115Vac-Rel2U	RCL 425730 230Vac-Rel2U	
Order No.	<b>4058580000</b>	<b>4058620000</b>	<b>4058640000</b>	
<b>Note</b>	Safely switches loads of: 100 mV...60 V AC/DC, 1 mA...300 mA. The gold layer may be destroyed by switching greater voltages.	Safely switches loads of: 100 mV...60 V AC/DC, 1 mA...300 mA. The gold layer may be destroyed by switching greater voltages.	Safely switches loads of: 100 mV...60 V AC/DC, 1 mA...300 mA. The gold layer may be destroyed by switching greater voltages.	

Accessories

PLUGSERIES

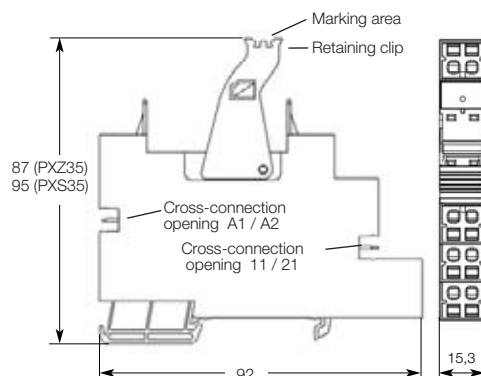

Technical data

Base without relay	
Nominal current	16 A
Nominal voltage	250 V
Dielectric strength coil/contact	> 4 kV
Ingress protection class	IP 20
Nominal cross-section	2.5 mm <sup>2</sup>
Stripping length	8 mm
	10 mm
Ambient temperature	-40 °C ... +60 °C
UL 94 flammability rating	V-0

screw connection  
tension clamp connection

Ordering data

Base for mounting on TS 35 DIN Rail			
Screw connection	Type	Qty	Order No.
Tension clamp connection	PXS35	10	8533771001
	PXZ35	10	8536691001

Retaining clip			
	PRC	100	8536700000

LED indicator with free wheel diode			
6 ... 24 V DC	PLED 24 V DC	20	8536710000
red LED, 6 ... 24 V DC	PLED 24 V DC rot	20	8611010000
48 ... 60 V DC	PLED 48 V DC	20	8536720000
115 V DC	PLED 115 V DC	20	8536730000
12 ... 24 V AC	PLED 24 V AC	20	8536750000
115 V AC	PLED 120 V AC	20	8536760000
230 V AC	PLED 230 V AC	20	8536780000
RC combination 120 ... 230 V AC/DC	PLRC 200 nF/200Ω	20	8566530000

Plug-in cross-connections				
2-pole	black	ZQV 2.5N/4-2SW	60	1784270000
	red	ZQV 2.5N/4-2RT	60	1784280000
	blue	ZQV 2.5N/4-2BL	60	1784290000

Markers				
	10 x 5 mm	WS 10/5	200	1060860000
	15 x 5 mm	WS 15/5	96	1609880000

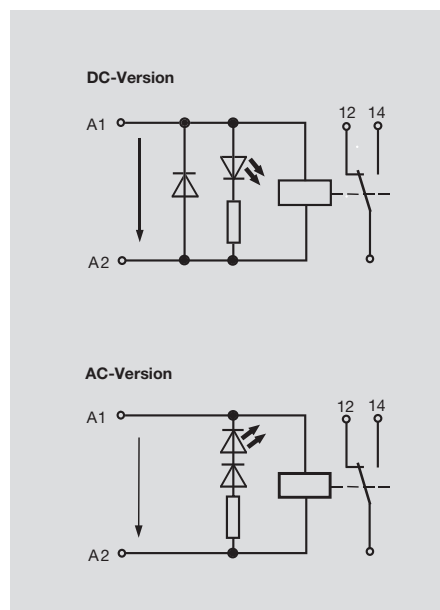
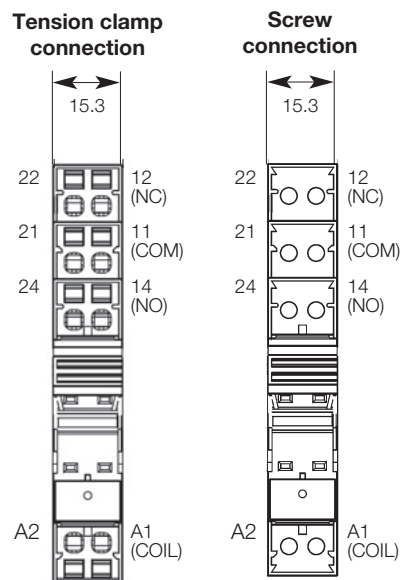

**Relays - RIDERSERIES**

**RCL relay  
1 CO contact AC/DC coil**

- 3000 or 4000 VA switching capacity
- Low height of 15.7 mm
- Hard gold-plated contacts available
- For boiler controls, timing relays, garage door controls, Interface modules

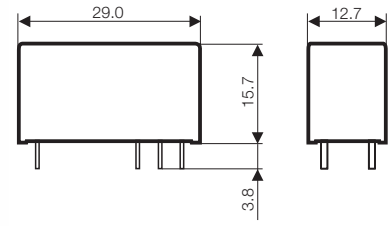

**C**

**PCB layout / terminal assignment**

View on solder pins, dimensions in mm

1 C/O changeover contacts

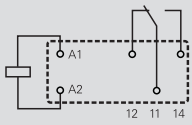

12 A, Pinning 3.5 mm

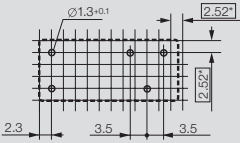

1 C/O changeover contacts

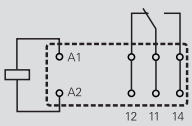

16 A, Pinning 5 mm

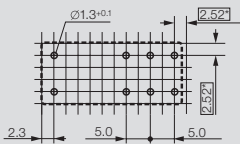

**Output**

max. switching voltage AC1	250 V
Continuous current	12 A for 3.5 mm / 16 A for 5 mm pinning
Contact base material	AgNi 90/10 or AgNi 5µm Au
Mechanical endurance	AC coil 10*10 <sup>6</sup> / DC coil 30*10 <sup>6</sup> switching operations
Response time / Drop-out time	7 ms / 3 ms

**Rated data**

Status indicator/Free wheel diode	no/no
Operating temperature	-40 °C...+70 °C
UL 94 flammability rating	V-0
Approvals	cURus; VDE;

**Insulation coordination (IEC 60664)**

Rated voltage	250 V
Creepage and clearance path input - output	10 mm
Surge category	III
Pollution severity	3
Protective separation to VDE 0106 part 101	yes

**Dimensions**

Length x width x height	mm	29 / 12.7 / 15.7
-------------------------	----	------------------

**Note**

**Applications**

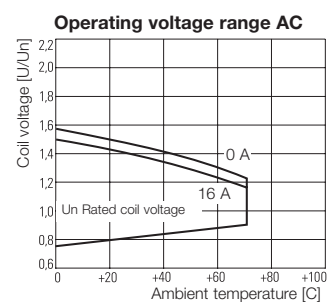
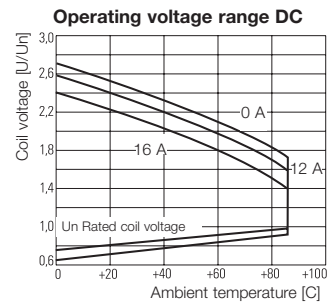
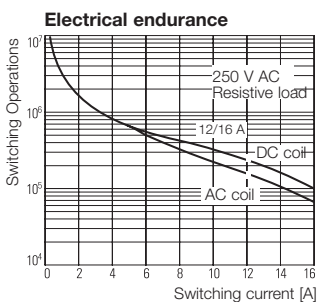
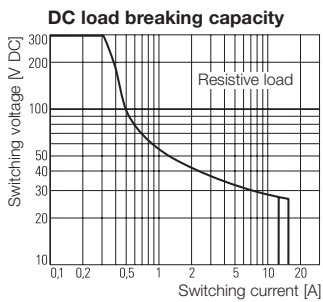

**RCL relay**  
**1 CO contact AC/DC coil**

Type code

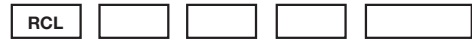

Type RIDER Control Low

Type of construction

- 1 12 A, Pitch 3.5 mm, flux proof
- 3 16 A, Pitch 5 mm, flux proof

Type of contact

- 1 1 CO contacts
- 3 1 NO contacts

Contact material

- 4 AgNi 90/10
- 5 AgNi 90/10 hgp

DC coil

- 006 6 V DC
- 012 12 V DC
- 024 24 V DC
- 048 48 V DC
- 060 60 V DC
- 110 110 V DC

AC coil

- 512 12 V AC
- 524 24 V AC
- 548 48 V AC
- 615 115 V AC
- 730 230 V AC

**Ordering data**

Input	6 V DC 1CO	12 V DC 1CO	24 V DC 1CO	48 V DC 1CO
Rated voltage	6 V DC	12 V DC	24 V DC	48 V DC
DC Response/dropout Volt	4.2 V / 0.6 V	8.4 V / 1.2 V	16.8 V / 2.4 V	33.6 V / 4.8 V
Power rating	500 mW	500 mW	500 mW	500 mW
Rated current DC	66.7 mA	33.3 mA	16.7 mA	8.7 mA
Coil resistance	90 Ω ±10%	360 Ω ±10%	1440 Ω ±10%	5520 Ω ±10%

Ordering data Relay	6 V DC 1CO	12 V DC 1CO	24 V DC 1CO	48 V DC 1CO
12 A / 3.5 mm Type	RCL114006	RCL114012	RCL114024	RCL114048
AgNi 90/10 Order No.	<b>8693400000</b>	<b>8693190000</b>	<b>8693180000</b>	<b>8693480000</b>
16 A / 5 mm Type	RCL314006	RCL314012	RCL314024	RCL314048
AgNi 90/10 Order No.	<b>8693800000</b>	<b>8693240000</b>	<b>8693260000</b>	<b>8693380000</b>
16 A / 5 mm Type	RCL315012	RCL315012	RCL315024	RCL315048
AgNi 5µm Au Order No.	<b>on request</b>	<b>on request</b>	<b>8824830000</b>	<b>on request</b>

Note	6 V DC 1CO	12 V DC 1CO	24 V DC 1CO	48 V DC 1CO

**Ordering data**

Input	24 V AC 1CO	48 V AC 1CO	115 V AC 1CO	230 V AC 1CO
Rated voltage	24 V AC	48 V AC	115 V AC	230 V AC
AC Response/dropout Volt	18.0 V / 3.6 V	64 V / 7.2 V	86.3 V / 17.3 V	172.5 V / 34.5 V
Power rating	0.75 VA	0.75 VA	0.75 VA	0.75 VA
Rated current AC	31.6 mA	15.6 mA	6.6 mA	3.2 mA
Coil resistance	1440 Ω ±10%	1420 Ω ±10%	8100 Ω ±15%	32500 Ω ±15%

Ordering data Relay	24 V AC 1CO	48 V AC 1CO	115 V AC 1CO	230 V AC 1CO
12 A / 3.5 mm Type	RCL114524	RCL114548	RCL114615	RCL114730
AgNi 90/10 Order No.	<b>8693220000</b>	<b>8693510000</b>	<b>8693390000</b>	<b>8693230000</b>
16 A / 5 mm Type	RCL314524	RCL314548	RCL314615	RCL314730
AgNi 90/10 Order No.	<b>8693500000</b>	<b>8693880000</b>	<b>8693890000</b>	<b>8693320000</b>
16 A / 5 mm Type	RCL315524	RCL315548	RCL315615	RCL315730
AgNi 5µm Au Order No.	<b>8824870000</b>	<b>on request</b>	<b>8824880000</b>	<b>8824890000</b>

Note	24 V AC 1CO	48 V AC 1CO	115 V AC 1CO	230 V AC 1CO

**Relays - RIDERSERIES**

**RCL relay  
2 CO contact AC/DC coil**

- 2000 VA switching capacity
- Low height of 15.7 mm
- Hard gold-plated contacts available
- For domestic appliances, heating controllers, emergency lighting systems, modems

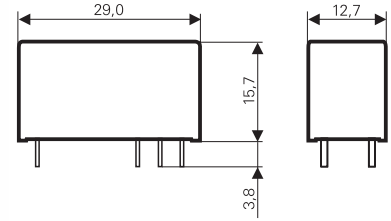

**C**

**Circuit diagram**  
View of connections  
Dimensions in mm

2 C/O changeover contacts

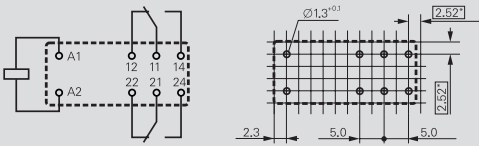

**Output**

max. switching voltage AC1	250 V
Continuous current	8 A / 1 contact
Contact base material	AgNi 90/10 or AgNi 5µm Au
Mechanical endurance	AC coil 5*10 <sup>6</sup> / DC coil 30*10 <sup>6</sup> switching operations
Response time / Drop-out time	7ms / 2ms

**Rated data**

Status indicator/Free wheel diode	no/no
Operating temperature	-40 °C...+70 °C
UL 94 flammability rating	V-0
Approvals	cURus; VDE;

**Insulation coordination (IEC 60664)**

Rated voltage	250 V
Creepage and clearance path input - output	10 mm
Surge category	III
Pollution severity	3
Protective separation to VDE 0106 part 101	yes

**Dimensions**

Length x width x height	mm	29 / 12.7 / 15.7
-------------------------	----	------------------

**Note**

**Applications**

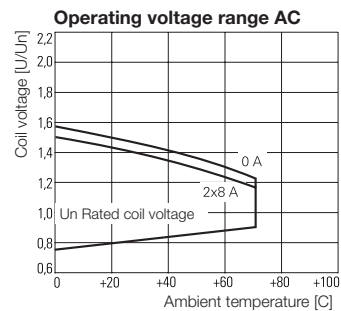
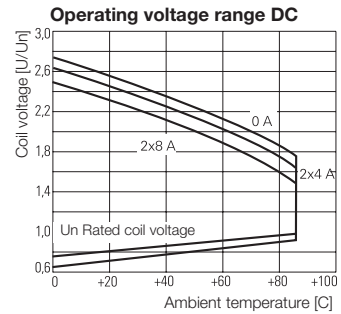
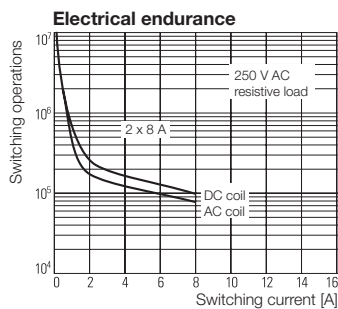
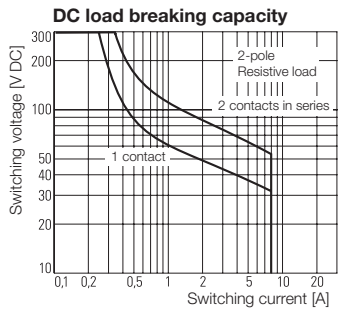

**RCL relay**  
**2 CO contact AC/DC coil**

Type code

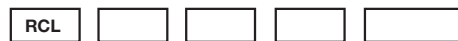

Type RIDER Control Low

Type of construction  
4 8 A, pitch 5 mm, flux proof

Type of contact

2 2 CO contacts  
4 2 NO contacts

Contact material

4 AgNi 90/10  
5 AgNi 90/10 hgp

DC coil

006 6 V DC  
012 12 V DC  
024 24 V DC  
048 48 V DC  
060 60 V DC  
110 110 V DC

AC coil

512 12 V AC  
524 24 V AC  
548 48 V AC  
615 115 V AC  
730 230 V AC

**Ordering data**

Input	12 V DC 2CO	24 V DC 2CO	48 V DC 2CO	110 V DC 2CO
Rated voltage	12 V DC	24 V DC	48 V DC	110 V DC
DC Response/dropout Volt	8.4 V / 1.2 V	16.8 V / 2.4 V	33.6 V / 4.8 V	77 V / 11 V
Power rating	500 mW	500 mW	500 mW	500 mW
Rated current DC	33.3 mA	16.7 mA	8,7 mA	4.1 mA
Coil resistance	360 Ω ±10%	1440 Ω ±10%	5620 Ω ±10%	26600 Ω ±12%

Ordering data Relay				
8 A / 5 mm Type	RCL 424012 12Vdc-Rel2U	RCL 424024 24Vdc-Rel2U	RCL424048	RCL 424110 110Vdc-Rel2U
AgNi 90/10 Order No.	<b>4058560000</b>	<b>4058570000</b>	<b>4058750000</b>	<b>4058590000</b>
Type Order No.				
8 A / 5 mm Type	RCL425012	RCL 425024 24Vdc-Rel2U	RCL425048	RCL425110
AgNi 5µm Au Order No.	<b>on request</b>	<b>4058580000</b>	<b>on request</b>	<b>8828370000</b>

Note				

**Ordering data**

Input	24 V AC 2CO	48 V AC 2CO	115 V AC 2CO	230 V AC 2CO
Rated voltage	24 V AC	48 V AC	115 V AC	230 V AC
AC Response/dropout Volt	18 V / 3.6 V	64 V / 7.2 V	86.3 V / 17.3 V	172.5 V / 34.5 V
Power rating	0.75 VA	0.75 VA	0.75 VA	0.75 VA
Rated current AC	31.6 mA	15,6 mA	6.6 mA	3.2 mA
Coil resistance	350 Ω ±10%	1420 Ω ±10%	8100 Ω ±15%	32500 Ω ±15%

Ordering data Relay				
8 A / 5 mm Type	RCL 424524 24Vac-Rel2U	RCL424548	RCL 424615 115Vac-Rel2U	RCL 424730 230Vac-Rel2U
AgNi 90/10 Order No.	<b>4058600000</b>	<b>8693340000</b>	<b>4058610000</b>	<b>4058630000</b>
Type Order No.				
8 A / 5 mm Type	RCL425524	RCL425548	RCL 425615 115Vac-Rel2U	RCL 425730 230Vac-Rel2U
AgNi 5µm Au Order No.	<b>on request</b>	<b>on request</b>	<b>4058620000</b>	<b>4058640000</b>

Note				

## Relays - RIDERSERIES

### RCLS – Inrush Power

- 1 NO
- High making currents possible
- RCLS3L 120 A for max. 20 ms
- RCLS3T 165 A for max. 20 ms / 800 A for 200 µs
- New contact principle

#### Switching contact for AgSnO2



#### Switching contact for AgSnO2+W

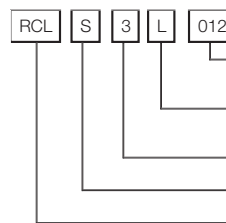

- Coil**  
012 = 12 V DC  
024 = 24 V DC
- Contact material**  
L = AgSnO2  
T = W-pre-make contact + AgSnO2
- Type of contact**  
3 = 1 NO
- Version**  
S = Inrush Power
- Type = RCL**

#### Circuit diagram

View of connections  
Dimensions in mm

1 NO contact

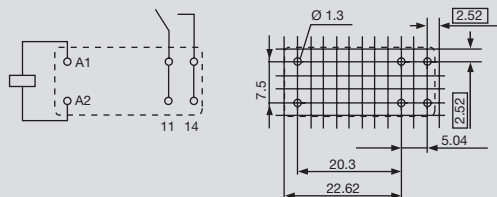

#### Output

Max. switching voltage AC	240 V
Rated current	16 A
Max. switching current	120 A @ 20 ms (RCLS3L) 165 A @ 20 ms / 800 A @ 200 µs (RCLS3T)
Contact base material	AgSnO2 (RCLS3L) / AgSnO2 + W (RCLS3T)
Mechanical endurance	10 x 10 <sup>6</sup> (RCLS3L) / 5 x 10 <sup>6</sup> (RCLS3T)
Response time / Release time	10 ms / 4 ms

#### Rated data

Ambient temp., fitted w/o distance	-25 °C ... +70 °C
Flammability rating UL 94	V-0
Approvals	cURus / VDE

#### Insulation coordinates (IEC 60664)

Rated voltage	250 V
Creepage and clearance path input – output	10 mm
Surge category	III
Pollution severity	2

#### Dimensions

Length x width x height	mm	29 / 12.7 / 15.7
-------------------------	----	------------------

#### Information

#### Order data

##### Input

Rated voltage	12 V DC
Rated current DC	33.3 mA
Power rating	400 mW
Oper. -/drop-out volt. DC-coil	8.4 V / 1.2 V

#### 12 V DC 1NO

Rated voltage	12 V DC
Rated current DC	33.3 mA
Power rating	400 mW
Oper. -/drop-out volt. DC-coil	8.4 V / 1.2 V

#### 24 V DC 1NO

Rated voltage	24 V DC
Rated current DC	16.7 mA
Power rating	400 mW
Oper. -/drop-out volt. DC-coil	16.8 V / 2.4 V

#### 12 V DC 1NO

Rated voltage	12 V DC
Rated current DC	33.3 mA
Power rating	400 mW
Oper. -/drop-out volt. DC-coil	8.4 V / 1.2 V

#### 24 V DC 1NO

Rated voltage	24 V DC
Rated current DC	16.7 mA
Power rating	400 mW
Oper. -/drop-out volt. DC-coil	16.8 V / 2.4 V

#### Order data

Break contact element	Type
Order No.	

RCLS 3L012  
**8866890000**

RCLS 3L024  
**8866900000**

RCLS 3T012  
**8866910000**

RCLS 3T024  
**8866920000**

#### Information

Contact material AgSnO2

Contact material AgSnO2

Contact material AgSnO2 + W

Contact material AgSnO2 + W

**Safe. Fast. RIDERSERIES.**

The RIDERSERIES relays with industrial pinning and bases with Push In connectivity.

Profit from the unbeatable advantages offered by the RIDERSERIES relays:

- Safe: industrial pinning
- Useful: free-wheeling diode and LED indicator
- Practical: test lever for mechanical operation of the contacts
- Fast: base with Push In connection
- Time-saving: cross connections can be instantly plugged-in



Discover the advantages of our new RIDERSERIES for yourself.

**Safe. Simple. RCI.**

The new RCI power relays from Weidmüller have been developed for use in industrial applications. Thanks to their outstanding contact properties, the relays can handle power up to 16 A with 24 Vdc or 230 Vac. To split the signal, simply use two change-over contacts, in which case the contacts each switch loads of up to 8 A with 24 Vdc or 230 Vac. As a handy extra detail, the AC and DC inputs are different colours for easy identification.



Establishing reliable connections: strong industrial pins for safe and fast assembly.

Reducing assembly time into the base: the integrated free-wheeling diode (DC) and the LED indicator.



Easy to use: test lever for mechanical operation of the contacts.



Simply release the catch and the test lever will click into place.

**Fast. Straightforward. Push In.**

RIDERSERIES relay bases are equipped with Push In connectivity. That means you need 75 % less time for wiring than for a relay base with a screw connection because solid and crimped conductors can simply be inserted without the need to open the clamping point. Other accessories include modules for input wiring, retaining clips and multicard markers.



Time-saving cross-connections: two-pin bridges for instantly pluggable electrical distribution in the input and output. You only need one clamping point for each Push In connection – the second one remains free for other connections!

It's never been so easy. Insert the conductor and you're done – a safe connection has been made! Each connection has two clamping points for conductors up to 1.5 mm<sup>2</sup>.



Extremely practical: a universal slot allows you to add modules to wire the relay coil, e.g. for varistors, resistances or RC combinations.



## Relays - RIDERSERIES

### RCI KIT with screw connection 1 changeover contact

- 4000 VA switching capacity
- Solid plug-in connections
- LED integrated in relay
- Protection circuit with DC coil
- Optional test button with lock function and sight window



C

#### DC version

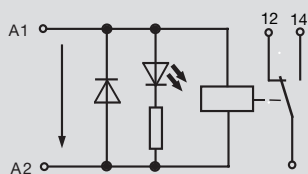

#### AC version

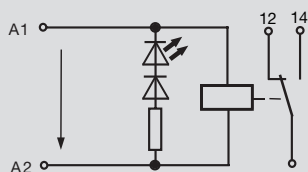

#### Output

max. switching voltage AC1	250 V
Continuous current	16 A
Contact base material	AgNi 90/10
Mechanical endurance	AC coil 5*10 <sup>6</sup> / DC coil 10*10 <sup>6</sup> switching operations
Response time / Drop-out time	7 ms / 3 ms

#### Rated data

Status indicator / Free wheel diode	yes / yes
Operating temperature	-40 °C...+70 °C
UL 94 flammability rating	V-0
Approvals	CE

#### Insulation coordination (IEC 60664)

Rated voltage	250 V
Creepage and clearance path input - output	8 mm
Surge category	III
Pollution severity	3
Protective separation to VDE 0106 part 101	yes

#### Dimensions

		Screw connection
Clamping range (rating- / min. / max.)	mm <sup>2</sup>	2.5 / 0.5 / 2.5
Length x width x height	mm	70 / 15.5 / 77

#### Note

#### Ordering data

Input	24 V DC 1CO	24 V AC 1CO	115 V AC 1CO	230 V AC 1CO
Rated voltage	24 V DC	24 V AC	115 V AC	230 V AC
Rated current AC		31.6 mA	6.6 mA	3.2 mA
Rated current DC	16.7 mA			
Power rating	400 mW	0.75 VA	0.75 VA	0.75 VA
AC Response/dropout Volt		18.0 V / 3.6 V	86.3 V / 17.3 V	172.5 V / 34.5 V
DC Response/dropout Volt	16.8 V / 2.4 V			
Coil resistance	1440 Ω ±10%	350 Ω ±10%	8100 Ω ±15%	32500 Ω ±15%

#### Ordering data

Complete module					
with test button	Type	RCIKIT 24VDC 1CO LD/PB	RCIKIT 24VAC 1CO LD/PB	RCIKIT 120VAC 1CO LD/PB	RCIKIT 230VAC 1CO LD/PB
	Order No.	8881580000	8881590000	8897060000	8881600000
without test button	Type	RCIKIT 24VDC 1CO LED	RCIKIT 24VAC 1CO LED	RCIKIT 120VAC 1CO LD	RCIKIT 230VAC 1CO LED
	Order No.	8871000000	8871010000	8897090000	8871020000

#### Ordering data

Spare relay, pluggable		w. test button	w.o. test button	w. test button	w.o. test button	w. test button	w.o. test button
	Type	RCI314AC4	RCI374AC4	RCI374R24	RCI314R24	RCI374S15	RCI314S15
	Order No.	8870100000	8870250000	8870280000	8870130000	8870290000	8870140000

Note					

**RCI-KITP with push-in connection  
1 changeover contact**

- 4000 VA switching capacity
- Solid plug-in connections
- LED integrated in relay
- Protection circuit with DC coil
- Optional test button with lock function and sight window



**DC version**

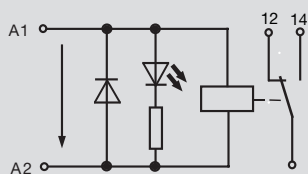

**AC version**

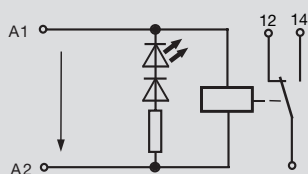

Output	
max. switching voltage AC1	250 V
Continuous current	16 A
Contact base material	AgNi 90/10
Mechanical endurance	AC coil 5*10 <sup>6</sup> / DC coil 10*10 <sup>6</sup> switching operations
Response time / Drop-out time	7 ms / 3 ms
Rated data	
Status indicator / Free wheel diode	yes / yes
Operating temperature	-40 °C...+70 °C
UL 94 flammability rating	V-0
Approvals	CE
Insulation coordination (IEC 60664)	
Rated voltage	250 V
Creepage and clearance path input - output	8 mm
Surge category	III
Pollution severity	3
Protective separation to VDE 0106 part 101	yes
Dimensions	
Clamping range (rating- / min. / max.)	mm <sup>2</sup> 1.5 / 0.5 / 1.5
Length x width x height	mm 70 / 15.5 / 98
Note	

**Ordering data**

Input	24 V DC 1CO	24 V AC 1CO	115 V AC 1CO	230 V AC 1CO
Rated voltage	24 V DC	24 V AC	115 V AC	230 V AC
Rated current AC		31.6 mA	6.6 mA	3.2 mA
Rated current DC	16.7 mA			
Power rating	400 mW	0.75 VA	0.75 VA	0.75 VA
AC Response/dropout Volt		18.0 V / 3.6 V	86.3 V / 17.3 V	172.5 V / 34.5 V
DC Response/dropout Volt	16.8 V / 2.4 V			
Coil resistance	1440 Ω ±10%	350 Ω ±10%	8100 Ω ±15%	32500 Ω ±15%

**Ordering data**

Complete module		24 V DC 1CO	24 V AC 1CO	115 V AC 1CO	230 V AC 1CO
with test button	Type	RCIKITP 24VDC 1CO LD/PB	RCIKITP 24VAC 1CO LD/PB	RCIKITP120VAC 1CO LD/PB	RCIKITP230VAC 1CO LD/PB
	Order No.	8897190000	8897200000	8897210000	8897220000
without test button	Type	RCIKITP 24VDC 1CO LD	RCIKITP 24VAC 1CO LD	RCIKITP 120VAC 1CO LD	RCIKITP 230VAC 1CO LD
	Order No.	8897110000	8897120000	8897130000	8897140000

**Ordering data**

Spare relay, pluggable		24 V DC 1CO		24 V AC 1CO		115 V AC 1CO		230 V AC 1CO	
		w. test button	w.o. test button	w. test button	w.o. test button	w. test button	w.o. test button	w. test button	w.o. test button
	Type	RCI314AC4	RCI374AC4	RCI374R24	RCI314R24	RCI374S15	RCI314S15	RCI314T30	RCI374T30
	Order No.	8870100000	8870250000	8870280000	8870130000	8870290000	8870140000	8870150000	8870300000

Note	

## Relays - RIDERSERIES

### RCI KIT with screw connection 2 changeover contacts

- 2000 VA switching capacity
- Solid plug-in connections
- LED integrated in the relay
- Protection circuit with DC coil
- Optional test button with lock function and sight window



C

#### DC version

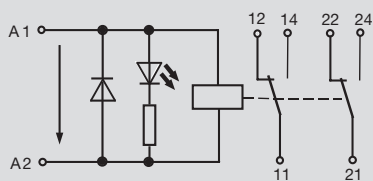

#### AC version

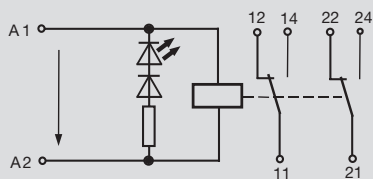

Output	
max. switching voltage AC1	250 V
Continuous current	8 A / 1 contact
Contact base material	AgNi 90/10
Mechanical endurance	AC coil 5*10 <sup>6</sup> / DC coil 10*10 <sup>6</sup> switching operations
Response time / Drop-out time	7 ms / 2 ms
Rated data	
Status indicator / Free wheel diode	yes / yes
Operating temperature	-40 °C...+70 °C
UL 94 flammability rating	V-0
Approvals	CE
Insulation coordination (IEC 60664)	
Rated voltage	250 V
Creepage and clearance path input - output	8 mm
Surge category	III
Pollution severity	3
Protective separation to VDE 0106 part 101	yes
Dimensions	
Clamping range (rating- / min. / max.)	mm <sup>2</sup> 2.5 / 0.5 / 2.5
Length x width x height	mm 70 / 15.5 / 77
Screw connection	
Note	

Ordering data	24 V DC 2CO	24 V AC 2CO	115 V AC 2CO	230 V AC 2CO
<b>Input</b>				
Rated voltage	24 V DC	24 V AC	115 V AC	230 V AC
Rated current AC		31.6 mA	6.6 mA	3.2 mA
Rated current DC	16.7 mA			
Power rating	400 mW	0.75 VA	0.75 VA	0.75 VA
AC Response/dropout Volt		18.0 V / 3.6 V	86.3 V / 17.3 V	172.5 V / 34.5 V
DC Response/dropout Volt	16.8 V / 2.4 V			
Coil resistance	1440 Ω ±10%	350 Ω ±10%	8100 Ω ±15%	32500 Ω ±15%
<b>Ordering data Complete module</b>				
with test button	Type RCIKIT 24VDC 2CO LD/PB	Type RCIKIT 24VAC 2CO LD/PB	Type RCIKIT 120VAC 2CO LD/PB	Type RCIKIT 230VAC 2CO LD/PB
	Order No. <b>8881610000</b>	Order No. <b>8881620000</b>	Order No. <b>8897080000</b>	Order No. <b>8881630000</b>
without test button	Type RCIKIT 24VDC 2CO LED	Type RCIKIT 24VAC 2CO LED	Type RCIKIT 120VAC 2CO LD	Type RCIKIT 230VAC 2CO LED
	Order No. <b>8871030000</b>	Order No. <b>8871040000</b>	Order No. <b>8897100000</b>	Order No. <b>8871050000</b>
<b>Ordering data Spare relay, pluggable</b>				
	<b>w. test button</b>	<b>w. test button</b>	<b>w. test button</b>	<b>w. test button</b>
Type	RCI424AC4	RCI484AC4	RCI424S15	RCI484S15
Order No.	<b>8870180000</b>	<b>8870320000</b>	<b>8870220000</b>	<b>8870360000</b>
<b>Note</b>				

**RCI-KITP with push-in connection  
2 changeover contacts**

- 2000 VA switching capacity
- Solid plug-in connections
- LED integrated in the relay
- Protection circuit with DC coil
- Optional test button with lock function and sight window



**DC version**

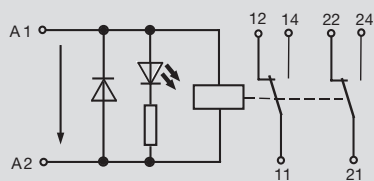

**AC version**

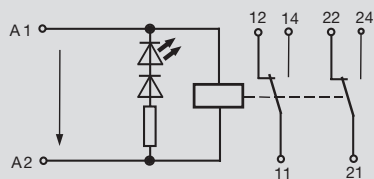

Output	
max. switching voltage AC1	250 V
Continuous current	8 A / 1 contact
Contact base material	AgNi 90/10
Mechanical endurance	AC coil 5*10 <sup>6</sup> / DC coil 10*10 <sup>6</sup> switching operations
Response time / Drop-out time	7 ms / 2 ms
Rated data	
Status indicator / Free wheel diode	yes / yes
Operating temperature	-40 °C...+70 °C
UL 94 flammability rating	V-0
Approvals	CE
Insulation coordination (IEC 60664)	
Rated voltage	250 V
Creepage and clearance path input - output	8 mm
Surge category	III
Pollution severity	3
Protective separation to VDE 0106 part 101	yes

Dimensions		Push-In
Clamping range (rating- / min. / max.)	mm <sup>2</sup>	1.5 / 0.5 / 1.5
Length x width x height	mm	70 / 15.5 / 98

**Note**

**Ordering data**

Input	24 V DC 2CO	24 V AC 2CO	115 V AC 2CO	230 V AC 2CO
Rated voltage	24 V DC	24 V AC	115 V AC	230 V AC
Rated current AC		31.6 mA	6.6 mA	3.2 mA
Rated current DC	16.7 mA			
Power rating	400 mW	0.75 VA	0.75 VA	0.75 VA
AC Response/dropout Volt		18.0 V / 3.6 V	86.3 V / 17.3 V	172.5 V / 34.5 V
DC Response/dropout Volt	16.8 V / 2.4 V			
Coil resistance	1440 Ω ±10%	350 Ω ±10%	8100 Ω ±15%	32500 Ω ±15%

**Ordering data**

Complete module		24 V DC 2CO	24 V AC 2CO	115 V AC 2CO	230 V AC 2CO
with test button	Type	RCIKITP 24VDC 2CO LD/PB	RCIKITP 24VAC 2CO LD/PB	RCIKITP120VAC 2CO LD/PB	RCIKITP230VAC 2CO LD/PB
	Order No.	<b>8897230000</b>	<b>8897240000</b>	<b>8897250000</b>	<b>8897260000</b>
without test button	Type	RCIKITP 24VDC 2CO LD	RCIKITP 24VAC 2CO LD	RCIKITP 120VAC 2CO LD	RCIKITP 230VAC 2CO LD
	Order No.	<b>8897150000</b>	<b>8897160000</b>	<b>8897170000</b>	<b>8897180000</b>

**Ordering data**

Spare relay, pluggable		w. test button		w.o. test button		w. test button		w.o. test button	
	Type	RCI424AC4	RCI484AC4	RCI424R24	RCI484R24	RCI424S15	RCI484S15	RCI484T30	RCI424T30
	Order No.	<b>8870180000</b>	<b>8870320000</b>	<b>8870210000</b>	<b>8870350000</b>	<b>8870220000</b>	<b>8870360000</b>	<b>8870370000</b>	<b>8870230000</b>

**Note**

**Relays - RIDERSERIES**

**RCI relay  
1 CO contact AC/DC coil**

- 4000 VA breaking capacity
- Sturdy plug-in connection
- Optional test button with lock function and window
- Optional status indicator
- Optional suppressor

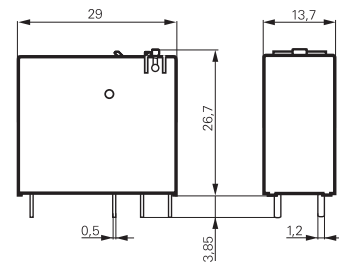

**C**

**Circuit diagram**

View on solder pins  
dimensions in mm

1 C/O changeover contacts

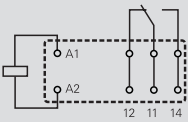

**Output**

max. switching voltage AC1	250 V
Continuous current	16 A
Contact base material	AgNi 90/10
Mechanical endurance	AC coil 5*10 <sup>6</sup> / DC coil 10*10 <sup>6</sup> switching operations
Response time / Drop-out time	7 ms / 3 ms

**Rated data**

Status indicator / Free wheel diode	see ordering data
Operating temperature	-40 °C...+70 °C
UL 94 flammability rating	V-0
Approvals	cURus; VDE; CE;

**Insulation coordination (IEC 60664)**

Rated voltage	250 V
Creepage and clearance path input - output	8 mm
Surge category	III
Pollution severity	3
Protective separation to VDE 0106 part 101	yes

**Dimensions**

Length x width x height mm

**Plug-in connection**

29 / 13.7 / x

**Note**

x = 25.5 without test button / 26.7 with test button

**Applications**

**DC load breaking capacity**

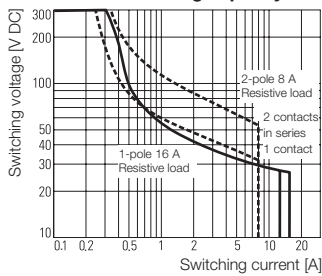

**Operating voltage range AC**

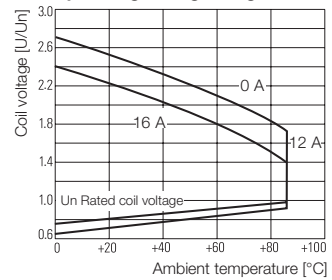

**Electrical endurance**

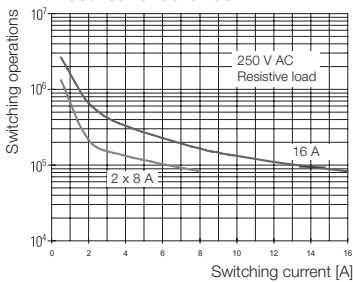

**Operating voltage range DC**

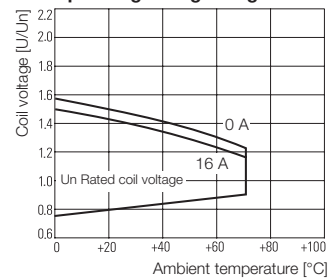

**RCI relay**  
**1 CO contact AC/DC coil**

<b>Type code</b>	RCI				
<b>Type</b>	RIDER Control Industrial				
<b>Type of construction</b>	3 1-pole, 16 A 4 2-pole, 8 A				
<b>Type of contact</b>	1 1 CO contact without test button 2 2 CO contacts without test button 7 1 CO contact with test button 8 2 CO contacts with test button				
<b>Contact material</b>	4 AgNi 90/10				
<b>Coil</b>	012 12 V DC 024 24 V DC 048 48 V DC 110 110 V DC 524 24 V AC 615 115 V AC 730 230 V AC AB2 12 V DC+LED+diode AC4 24 V DC+LED+diode AE8 48 V DC+LED+diode BB0 110 V DC+LED+diode R24 24 V AC+LED S15 115 V AC+LED T30 230 V AC+LED				

**Ordering data**

	12 V DC 1CO	24 V DC 1CO	48 V DC 1CO	110 V DC 1CO
<b>Input</b>				
Rated voltage	12 V DC	24 V DC	48 V DC	110 V DC
DC Response/dropout Volt	8.4 V / 1.2 V	16.8 V / 2.4 V	33.6 V / 4.8 V	77 V / 11 V
Power rating	400 mW	400 mW	400 mW	400 mW
Rated current DC	33.3 mA	16.7 mA	8.7 mA	4.1 mA
Coil resistance	360 Ω ±10%	1440 Ω ±10%	5620 Ω ±10%	26600 Ω ±12%

Ordering data Relais	12 V DC 1CO	24 V DC 1CO	48 V DC 1CO	110 V DC 1CO
Standard Type	RCI314012	RCI314024	RCI314048	RCI314110
Order No.	<b>8869800000</b>	<b>8869810000</b>	<b>8869820000</b>	<b>8869830000</b>
with test button Type	RCI374012	RCI374024	RCI374048	RCI374110
Order No.	<b>8869950000</b>	<b>8869960000</b>	<b>8869970000</b>	<b>8869980000</b>
with LED + protective diode* Type	RCI314AB2	RCI314AC4	RCI314AE8	RCI314BB0
Order No.	<b>8870090000</b>	<b>8870100000</b>	<b>8870110000</b>	<b>8870120000</b>
with test button + LED Type	RCI374AB2	RCI374AC4	RCI374AE8	RCI374BB0
+ protective diode* Order No.	<b>8870240000</b>	<b>8870250000</b>	<b>8870260000</b>	<b>8870270000</b>
<b>Note</b>	*Protective diode only with DC input			

**Ordering data**

	24 V AC 1CO	115 V AC 1CO	230 V AC 1CO
<b>Input</b>			
Rated voltage	24 V AC	115 V AC	230 V AC
AC Response/dropout Volt	18.0 V / 3.6 V	86.3 V / 17.3 V	172.5 V / 34.5 V
Power rating	0.75 VA	0.75 VA	0.75 VA
Rated current AC	31.6 mA	6.6 mA	3.2 mA
Coil resistance	350 Ω ±10%	8100 Ω ±15%	32500 Ω ±15%

Ordering data Relais	24 V AC 1CO	115 V AC 1CO	230 V AC 1CO
Standard Type	RCI314524	RCI314615	RCI314730
Order No.	<b>8869840000</b>	<b>8869850000</b>	<b>8869860000</b>
with test button Type	RCI374524	RCI374615	RCI374730
Order No.	<b>8869990000</b>	<b>8870000000</b>	<b>8870010000</b>
with LED Type	RCI314R24	RCI314S15	RCI314T30
Order No.	<b>8870130000</b>	<b>8870140000</b>	<b>8870150000</b>
with test button + LED Type	RCI374R24	RCI374S15	RCI374T30
Order No.	<b>8870280000</b>	<b>8870290000</b>	<b>8870300000</b>
<b>Note</b>			

**Relays - RIDERSERIES**

**RCI relay  
2 CO contact AC/DC coil**

- 2000 VA breaking capacity
- Sturdy plug-in connection
- Optional test button with lock function and window
- Optional status indicator
- Optional suppressor

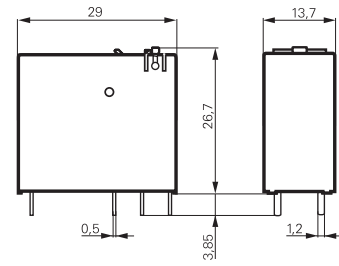

**C**

**Circuit diagram**  
View on solder pins  
dimensions in mm

2 C/O changeover contacts

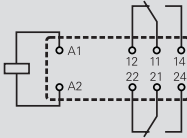

Output	
max. switching voltage AC1	250 V
Continuous current	8 A / 1 contact
Contact base material	AgNi 90/10
Mechanical endurance	AC coil 5*10 <sup>6</sup> / DC coil 10*10 <sup>6</sup> switching operations
Response time / Drop-out time	7 ms / 2 ms
Rated data	
Status indicator / Free wheel diode	see ordering data
Operating temperature	-40 °C...+70 °C
UL 94 flammability rating	V-0
Approvals	cURus; VDE;
Insulation coordination (IEC 60664)	
Rated voltage	250 V
Creepage and clearance path input - output	8 mm
Surge category	III
Pollution severity	3
Protective separation to VDE 0106 part 101	yes
Dimensions	
Length x width x height	mm 29 / 13.7 / x
Plug-in connection	
<b>Note</b>	x = 25.5 without test button / 26.7 with test button

**Applications**

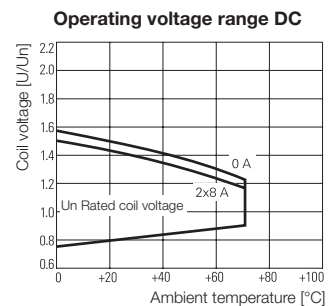
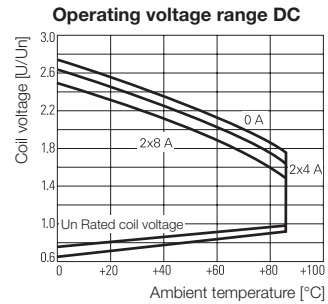
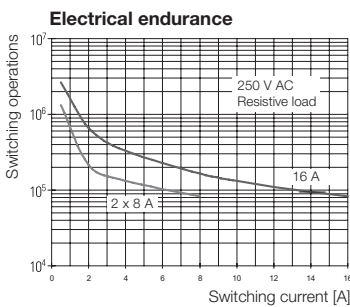
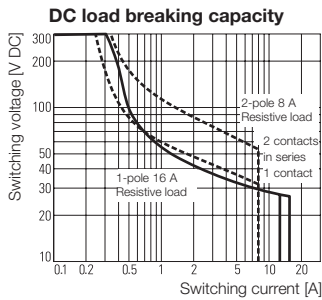

**RCI relay**  
**2 CO contact AC/DC coil**

<b>Type code</b>	RCI				
<b>Type</b>	RIDER Control Industrial				
<b>Type of construction</b>	3 1-pole, 16 A 4 2-pole, 8 A				
<b>Type of contact</b>	1 1 CO contact without test button 2 2 CO contacts without test button 7 1 CO contact with test button 8 2 CO contacts with test button				
<b>Contact material</b>	4 AgNi 90/10				
<b>Coil</b>	012 12 V DC 024 24 V DC 048 48 V DC 110 110 V DC 524 24 V AC 615 115 V AC 730 230 V AC AB2 12 V DC+LED+diode AC4 24 V DC+LED+diode AE8 48 V DC+LED+diode BB0 110 V DC+LED+diode R24 24 V AC+LED S15 115 V AC+LED T30 230 V AC+LED				

**Ordering data**

	12 V DC 2CO	24 V DC 2CO	48 V DC 2CO	110 V DC 2CO
<b>Input</b>				
Rated voltage	12 V DC	24 V DC	48 V DC	110 V DC
DC Response/dropout Volt	8.4 V / 1.2 V	16.8 V / 2.4 V	33.6 V / 4.8 V	77 V / 11 V
Power rating	400 mW	400 mW	400 mW	400 mW
Rated current DC	33.3 mA	16.7 mA	8.7 mA	4.1 mA
Coil resistance	360 Ω ±10%	1440 Ω ±10%	5620 Ω ±10%	26600 Ω ±12%

**Ordering data**  
**Relais**

	12 V DC 2CO	24 V DC 2CO	48 V DC 2CO	110 V DC 2CO
Standard	RCI424012	RCI424024	RCI424048	RCI424110
Type				
Order No.	<b>8869870000</b>	<b>8869890000</b>	<b>8869900000</b>	<b>8869910000</b>
with test button	RCI484012	RCI484024	RCI484048	RCI484110
Type				
Order No.	<b>8870020000</b>	<b>8870030000</b>	<b>8870040000</b>	<b>8870050000</b>
with LED + protective diode*	RCI424AB2	RCI424AC4	RCI424AE8	RCI424BB0
Type				
Order No.	<b>8870170000</b>	<b>8870180000</b>	<b>8870190000</b>	<b>8870200000</b>
with test button + LED	RCI484AB2	RCI484AC4	RCI484AE8	RCI484BB0
Type				
Order No.	<b>8870310000</b>	<b>8870320000</b>	<b>8870330000</b>	<b>8870340000</b>

**Note**  
\*Protective diode only with DC input

**Ordering data**

	24 V AC 2CO	115 V AC 2CO	230 V AC 2CO	
<b>Input</b>				
Rated voltage	24 V AC	115 V AC	230 V AC	
AC Response/dropout Volt	18 V / 3.6 V	86.3 V / 17.3 V	172.5 V / 34.5 V	
Power rating	0.75 VA	0.75 VA	0.75 VA	
Rated current AC	31.6 mA	6.6 mA	3.2 mA	
Coil resistance	350 Ω ±10%	8100 Ω ±15%	32500 Ω ±15%	

**Ordering data**  
**Relais**

	24 V AC 2CO	115 V AC 2CO	230 V AC 2CO	
Standard	RCI424524	RCI424615	RCI424730	
Type				
Order No.	<b>8869920000</b>	<b>8869930000</b>	<b>8869940000</b>	
with test button	RCI484524	RCI484615	RCI484730	
Type				
Order No.	<b>8870060000</b>	<b>8870070000</b>	<b>8870080000</b>	
with LED	RCI424R24	RCI424S15	RCI424T30	
Type				
Order No.	<b>8870210000</b>	<b>8870220000</b>	<b>8870230000</b>	
with test button + LED	RCI484R24	RCI484S15	RCI484T30	
Type				
Order No.	<b>8870350000</b>	<b>8870360000</b>	<b>8870370000</b>	

**Note**

**Relays - RIDERSERIES**

**RCH Safety Relay  
DC coil**

- Relay with positively driven contacts to EN 50205
- 2 CO contacts or 1 NOC + 1 NCC
- 1500 VA switching capacity
- 6 kV impulse withstand voltage

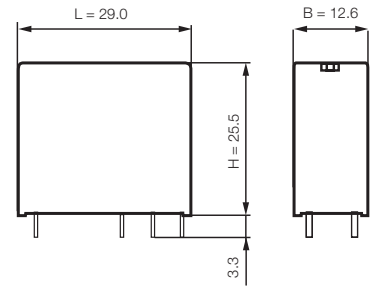

**C**

**Circuit diagram**  
View of connections

2 changeover contacts

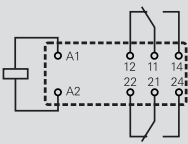

1 NOC + 1 NCC

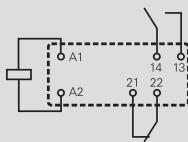

Output	
max. switching voltage AC1	250 V
Continuous current	6 A
Contact base material	AgNi
Mechanical endurance	10 <sup>4</sup> switching cycles
Response time / Drop-out time	10 ms / 4 ms
Rated data	
Status indicator/Free wheel diode	no/no
Operating temperature	-25 °C...+70 °C
Approvals	cURus;
Insulation coordination (IEC 60664)	
Rated voltage	250 V
Creepage and clearance path input - output	8 mm
Surge category	III
Pollution severity	2
Protective separation to VDE 0106 part 101	yes
Dimensions	
Length x width x height	mm 29 / 12.6 / 25.5
Note	

Ordering data	12 V DC 2CO	24 V DC 2CO	12 V DC 1NC / 1NO	24 V DC 1NC / 1NO
<b>Input</b>				
Rated voltage	12 V DC	24 V DC	12 V DC	24 V DC
Rated current AC				
Rated current DC	58.3 mA	29.2 mA	58.3 mA	29.2 mA
Power rating	700 mW	700 mW	700 mW	700 mW
AC Response/dropout Volt				
DC Response/dropout Volt	9.0 V / 1.2 V	18.0 V / 2.4 V	9.0 V / 1.2 V	18.0 V / 2.4 V

<b>Ordering data</b>				
NCC/NOC	Type		RCH S51012	RCH S51024
	Order No.		<b>8768670000</b>	<b>8768700000</b>
CO contact	Type	RCH S21012	RCH S21024	
	Order No.	<b>8768660000</b>	<b>8768680000</b>	
<b>Ordering data</b>				
	Type			
	Order No.			
<b>Note</b>				

Accessories for RCI relays  
Plug-in module with screw or Push In connection

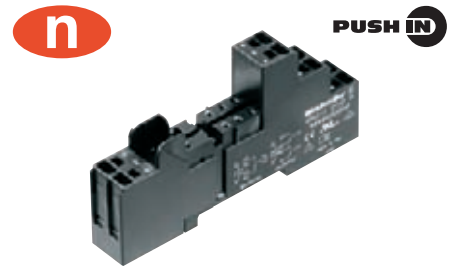
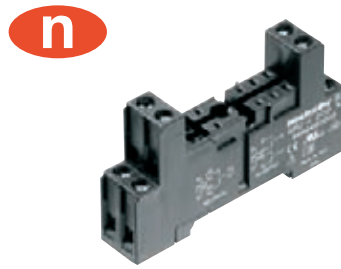
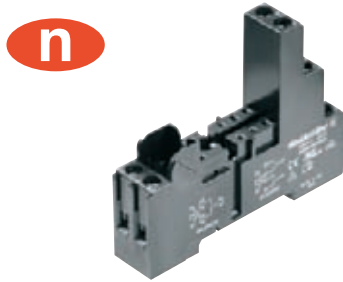

Ordering data

Description
Plug-in module with screw connections (only for RCL relays), pitch 3.5 mm, snaps onto DIN mounting rail, 1-pole
Plug-in module with screw connections, pitch 5 mm, snaps onto DIN mounting rail, 2-pole
Plug-in module with screw connections, pitch 5 mm, snaps onto DIN mounting rail, 2-pole
Plug-in module with Push In connections, pitch 5 mm, snaps onto DIN mounting rail, 2-pole

Type	Qty.	Order No.
SRC-I 1CO	10	8869470000
SRC-I 2CO	10	8869490000
SRC-I 2CO N	10	8869480000
SRC-I 2CO P	10	8869500000

Technical data

Nominal current	1-pole	12 A
	2-pole	2 x 12 A*)
Nominal voltage		240 V~
Dielectric strength, screw/Push In connection		>3000 Veff / 4000 Veff
Ambient temperature		-25 °C ... +85 °C
Ingress protection		IP 20
Connection cross-section (screw connection) / with ferrules		2 x 2.5 mm <sup>2</sup> / 2 x 1.5 mm <sup>2</sup>
Connection cross-section (Push In conn.) / with ferrules		2 x 1.5 mm <sup>2</sup> / 2 x 1.0 mm <sup>2</sup>
Terminal torque / max.		0.5 Nm / 0.7 Nm

\*) With 1-pole relays (16 A), the following terminal connections are required: 11 with 21, 12 with 22, 14 with 24.

Insulation according to IEC 60644-1

Rated voltage	250 V
Pollution severity	2
Surge category	III

Accessories

Description	Type	Qty.	Order No.
Plastic retaining	SRC-I CLIP HP	10	8869510000
Marking tag	SRC-I MARK	10	8869530000
Multicard 6 x 15 mm	ESG 6/15 K MC NEUTR. WS	200	1880100000
Cross-connection for push-in base, 2-pole	SRC-I QV	10	8870840000

LED and protection modules for SRC-I

Plug simply into the base module; reverse-connect protection. Connect parallel to coil.

Ordering data

Description	Type	Qty.	Order No.	Order No.
Free Wheel diode 1N4007	RIM-I 1 6/230V	10	8869580000	
Resistor 62 kOhm 1 Watt	RIM-I 1 R 110/230V	10	8870830000	
RC element 6 ... 60 V AC	RIM-I 3 6/60VAC	10	8869770000	
RC element 110 ... 230 V AC	RIM-I 3 110/230VAC	10	8869790000	
Varistor protection 24 V	RIM-I 4 24VUC	10	8869710000	
Varistor protection 110 V	RIM-I 4 110VUC	10	8869730000	
Varistor protection 230 V	RIM-I 4 230VUC	10	8869750000	
<b>LED</b>			<b>red</b>	<b>green</b>
LED 6 ... 24 V DC with free wheel diode	RIM-I 2 6/24VDC	10	8869590000	8869600000
LED 24 ... 60 V DC with free wheel diode	RIM-I 2 24/60VDC	10	8869670000	8869680000
LED 110 ... 230 V DC with free wheel diode	RIM-I 2 110/230VDC	10	8869690000	8869700000
LED 6 ... 24 V DC / V AC	RIM-I 3 6/24VUC	10	8869630000	8869640000
LED 24 ... 60 V DC / V AC	RIM-I 3 24/60VUC	10	8869610000	8869620000
LED 110 ... 230 V DC / V AC	RIM-I 3 110/230VUC	10	8869650000	8869660000

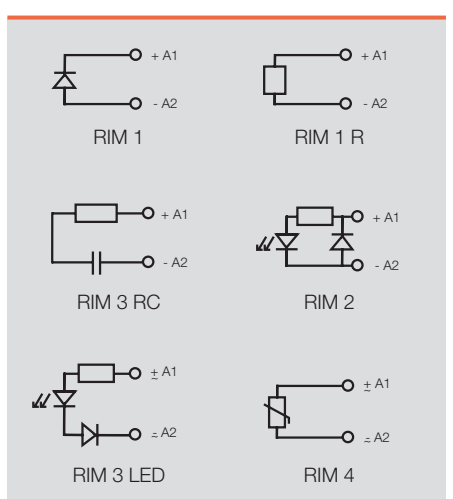
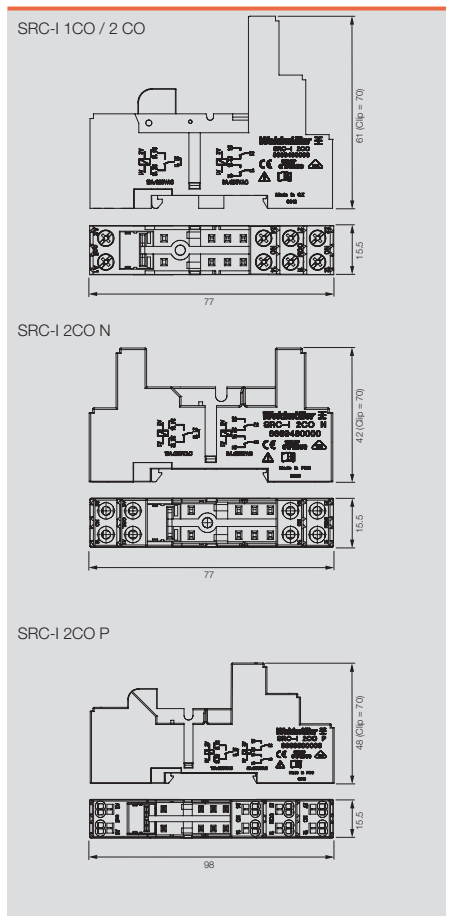

## Relays - RIDERSERIES

### RCM KIT 2 CO contact AC/DC coil

Modular system consisting of:

- rail mounting relay base
- LED indicator unit
- retaining clip
- pluggable relay
- markers

Independent connection system:

- screw or push-in technology

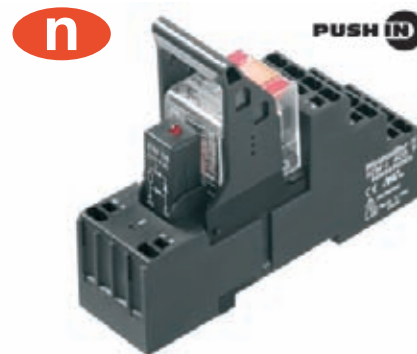

C

#### DC version

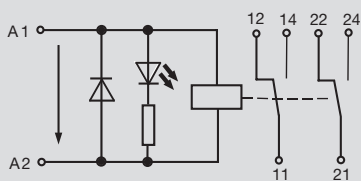

#### AC version

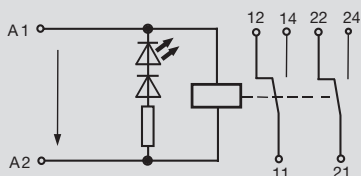

#### Output

max. switching voltage AC1	250 V
Continuous current	12 A
Contact base material	AgNi 90/10
Mechanical endurance	AC coil 20*10° / DC coil 30*10° switching operations
Response time / Drop-out time	15ms / 10ms

#### Rated data

Status indicator/Free wheel diode	Green LED = DC coil; red LED = AC coil/Yes
Operating temperature	-40 °C...+70 °C
UL 94 flammability rating	V-0
Approvals	CE

#### Insulation coordination (IEC 60664)

Rated voltage	240 V
Creepage and clearance path input - output	≤ 4mm
Surge category	III
Pollution severity	2

	Screw connection	Push-In connection
Clamping range (rating- / min. / max.)	mm² 2.5 / 0.5 / 2.5	1.5 / 0.5 / 1.5
Length x width x height	mm 75 / 27 / 82	96 / 31 / 60

#### Note

#### Ordering data

Input	24 V DC 2CO LED	24 V AC 2CO LED	115 V AC 2CO	230 V AC 2CO LED
Rated voltage	24 V DC	24 V AC	115 V AC	230 V AC
Rated current AC		41.6 mA	8.8 mA	4.3 mA
Rated current DC	31.3 mA			
Power rating	750 mW	1.0 VA	1.0 VA	1.0 VA
AC Response/dropout Volt		19.2 V / 7.2 V	92 V / 34.5 V	184.0 V / 69.0 V
DC Response/dropout Volt	18.0 V / 2.4 V			

#### Ordering data

Complete module					
Screw connection	Type	RCMKIT-I 24VDC 2CO LD	RCMKIT-I 24VAC 2CO LD	RCMKIT-I 115VAC 2CO LD	RCMKIT-I 230VAC 2CO LD
	Order No.	8920940000	8920950000	8920960000	8920970000
Push-In connection	Type	RCMKITP-I 24VDC 2CO LD	RCMKITP-I 24VAC 2CO LD	RCMKITP-I 115VAC 2CO LD	RCMKITP-I 230VAC 2CO LD
	Order No.	8921080000	8921090000	8921100000	8921110000

#### Ordering data

Spare relay, pluggable					
	Type	RCM270024	RCM270524	RCM270615	RCM270730
	Order No.	8689860000	8689760000	8689800000	8689820000

Note				



**RCM KIT**  
**3 CO contact**  
**AC/DC coil**

Modular system consisting of:

- rail mounting relay base
- LED indicator unit
- retaining clip
- pluggable relay
- markers



**DC version**

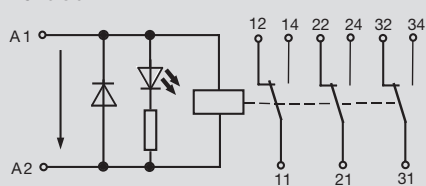

**AC version**

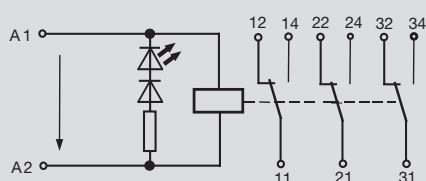

Output	
max. switching voltage AC1	250 V
Continuous current	10 A
Contact base material	AgNi 90/10
Mechanical endurance	AC coil 20*10 <sup>6</sup> / DC coil 30*10 <sup>6</sup> switching operations
Response time / Drop-out time	15ms / 10ms
Rated data	
Status indicator/Free wheel diode	Green LED = DC coil; red LED = AC coil/Yes
Operating temperature	-40 °C...+70 °C
UL 94 flammability rating	V-0
Approvals	CE
Insulation coordination (IEC 60664)	
Rated voltage	240 V
Creepage and clearance path input - output	≤ 4mm
Surge category	III
Pollution severity	2

	Screw connection	Push-In connection
Clamping range (rating- / min. / max.)	mm <sup>2</sup> 2.5 / 0.5 / 2.5	
Length x width x height	mm 75 / 27 / 82	

Note

**Ordering data**

Input	24 V DC 3CO LED	24 V AC 3CO LED	115 V AC 3CO LED	230 V AC 3CO LED
Rated voltage	24 V DC	24 V AC	115 V AC	230 V AC
Rated current AC		41.6 mA	8.8 mA	4.3 mA
Rated current DC	31.3 mA			
Power rating	750 mW	1.0 VA	1.0 VA	1.0 VA
AC Response/dropout Volt		19.2 V / 7.2 V	92 V / 34.5 V	184.0 V / 69.0 V
DC Response/dropout Volt	18.0 V / 2.4 V			

Ordering data	24 V DC 3CO LED	24 V AC 3CO LED	115 V AC 3CO LED	230 V AC 3CO LED
<b>Complete module</b>				
Screw connection Type	RCMKIT-I 24VDC 3CO LD	RCMKIT-I 24VAC 3CO LD	RCMKIT-I 115VAC 3CO LD	RCMKIT-I 230VAC 3CO LD
Order No.	8920980000	8920990000	8921010000	8921020000
Push-In connection Type				
Order No.				

Ordering data	24 V DC 3CO LED	24 V AC 3CO LED	115 V AC 3CO LED	230 V AC 3CO LED
<b>Spare relay, pluggable</b>				
Type	RCM370024	RCM370524	RCM370615	RCM370730
Order No.	8690040000	8690030000	8689980000	8690000000

Note	24 V DC 3CO LED	24 V AC 3CO LED	115 V AC 3CO LED	230 V AC 3CO LED

## Relays - RIDERSERIES

### RCM KIT 4 CO contact AC/DC coil

Modular system consisting of:

- rail mounting relay base
- LED indicator unit
- retaining clip
- pluggable relay
- markers

Independent connection system:

- screw or push-in technology

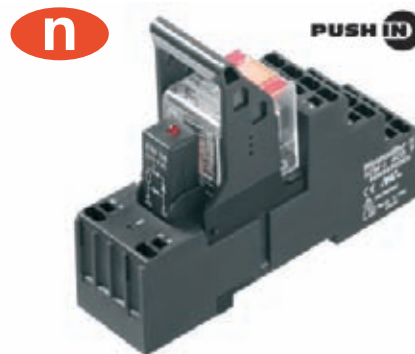

#### DC version

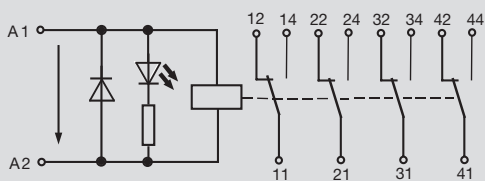

#### AC version

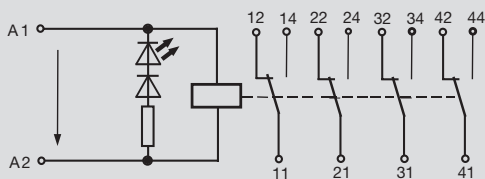

Output	
max. switching voltage AC1	250 V
Continuous current	6 A
Contact base material	AgNi 90/10
Mechanical endurance	AC coil 20*10° / DC coil 30*10° switching operations
Response time / Drop-out time	15ms / 10ms
Rated data	
Status indicator/Free wheel diode	Green LED = DC coil; red LED = AC coil/Yes
Operating temperature	-40 °C...+70 °C
UL 94 flammability rating	V-0
Approvals	CE
Insulation coordination (IEC 60664)	
Rated voltage	240 V
Creepage and clearance path input - output	≤ 3mm
Surge category	III
Pollution severity	2

	Screw connection	Push-In connection
Clamping range (rating- / min. / max.)	mm² 2.5 / 0.5 / 2.5	1.5 / 0.5 / 1.5
Length x width x height	mm 75 / 27 / 82	96 / 31 / 60

**Note**

#### Ordering data

Input	24 V DC 4CO LED	24 V AC 4CO LED	115 V AC 4CO LED	230 V AC 4CO LED
Rated voltage	24 V DC	24 V AC	115 V AC	230 V AC
Rated current AC		41.6 mA	8.8 mA	4.3 mA
Rated current DC	31.3 mA			
Power rating	750 mW	1.0 VA	1.0 VA	1.0 VA
AC Response/dropout Volt		19.2 V / 7.2 V	92 V / 34.5 V	184.0 V / 69.0 V
DC Response/dropout Volt	18.0 V / 2.4 V			

#### Ordering data

Complete module					
Screw connection	Type	RCMKIT-I 24VDC 4CO LD	RCMKIT-I 24VAC 4CO LD	RCMKIT-I 115VAC 4CO LD	RCMKIT-I 230VAC 4CO LD
	Order No.	<b>8921030000</b>	<b>8921040000</b>	<b>8921050000</b>	<b>8921060000</b>
Push-In connection	Type	RCMKITP-I 24VDC 4CO LD	RCMKITP-I 24VAC 4CO LD	RCMKITP-I 115VAC 4CO LD	RCMKITP-I 230VAC 4CO LD
	Order No.	<b>8921120000</b>	<b>8921130000</b>	<b>8921140000</b>	<b>8921150000</b>

#### Ordering data

Spare relay, pluggable					
	Type	RCM570024	RCM570524	RCM570615	RCM570730
	Order No.	<b>8690200000</b>	<b>8690110000</b>	<b>1180800000</b>	<b>1181100000</b>

Note				

Accessories for miniature relays RCM-I  
Plug-in module with screw or Push In connection

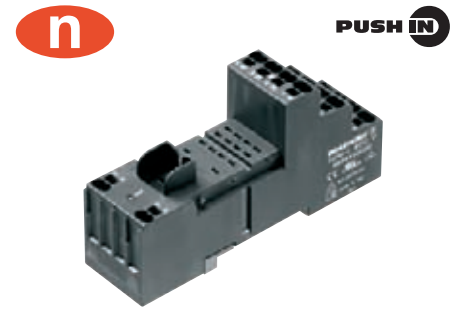
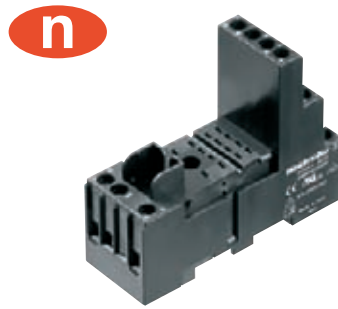
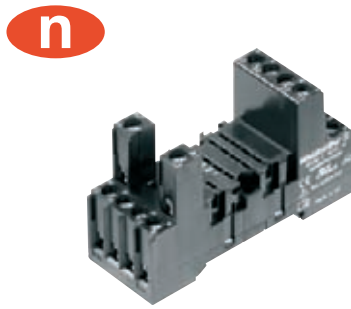

Ordering data

Description
Plug-in module with screw connections, snap-on installation, 2-pole
Plug-in module with screw connections, snap-on installation, 3-pole
Plug-in module with screw connections, snap-on installation, 4-pole
Plug-in module with screw connections, snaps onto DIN mounting rails, 4-pole
Plug-in module with Push In connections, snaps onto DIN mounting rails, 2-pole
Plug-in module with Push In connections, snaps onto DIN mounting rails, 4-pole

Type	Qty.	Order No.
SCM-I 2CO	10	8869400000
SCM-I 3CO N	10	8869410000
SCM-I 4CO	10	8869420000
SCM-I 4CO N	10	8869390000
SCM-I 2CO P	10	8876220000
SCM-I 4CO P	10	8869430000

Technical data

Nominal current	4-pole 6 A, 3-pole 10 A, 2-pole 12 A
Nominal voltage	300 V AC
Dielectric strength, coil/contacts	> 2500 Veff
Insulation group (VDE 0110b)	C / 250 V AC
Ambient temperature	-45 ... +70 °C <sup>1)</sup>
Protection class (IEC 61810)	IP 20
Connection cross-section (Push In connections) / with ferrules	2 x 1.5 mm <sup>2</sup> / 2 x 1.0 mm <sup>2</sup>
Connection cross-section (screw connections) / with ferrules	2 x 2.5 mm <sup>2</sup> / 2 x 1.5 mm <sup>2</sup>
Terminal torque (screw connection)	0.5 Nm
Max.	0.7 Nm
<sup>1)</sup> At nominal current up to +40 °C, up to +70 °C at 70 %	

Accessories

Description
Plastic retaining clip
Plastic retaining clip
Metal retaining clip
Markers, individual
Markers, MultiCard
Cross-connection for push-in base, 2-pole

Type	Qty.	Order No.
SCM-I CLIP P	10	8869440000
SCM-I CLIP N	10	8875620000
SCM-I CLIP M	10	8869450000
SCM-I MARK	10	8869460000
ESG 9/11 K MC neutral	200	1857440000
SCM-I QV	10	8870850000

LED and protection modules for SCM-I

Plug simply into the base module; reverse-connect protection. Connect parallel to coil.

Bestelldaten

Description
Free Wheel diode 1N4007
Resistor 62 kOhm 1 Watt
RC element 6 ... 60 V AC
RC element 110 ... 230 V AC
Varistor protection 24 V
Varistor protection 110 V
Varistor protection 230 V
<b>LED</b>
LED 6 ... 24 V DC with free wheel diode
LED 24 ... 60 V DC with free wheel diode
LED 110 ... 230 V DC with free wheel diode
LED 6 ... 24 V DC / V AC
LED 24 ... 60 V DC / V AC
LED 110 ... 230 V DC / V AC

Type	Qty.	Order No.	Order No.
RIM-I 1 6/230V	10	8869580000	
RIM-I 1 R 110/230V	10	8870830000	
RIM-I 3 6/60VAC	10	8869770000	
RIM-I 3 110/230VAC	10	8869790000	
RIM-I 4 24VUC	10	8869710000	
RIM-I 4 110VUC	10	8869730000	
RIM-I 4 230VUC	10	8869750000	
		<b>red</b>	<b>green</b>
RIM-I 2 6/24VDC	10	8869590000	8869600000
RIM-I 2 24/60VDC	10	8869670000	8869680000
RIM-I 2 110/230VDC	10	8869690000	8869700000
RIM-I 3 6/24VUC	10	8869630000	8869640000
RIM-I 3 24/60VUC	10	8869610000	8869620000
RIM-I 3 110/230VUC	10	8869650000	8869660000

Dimensions in mm

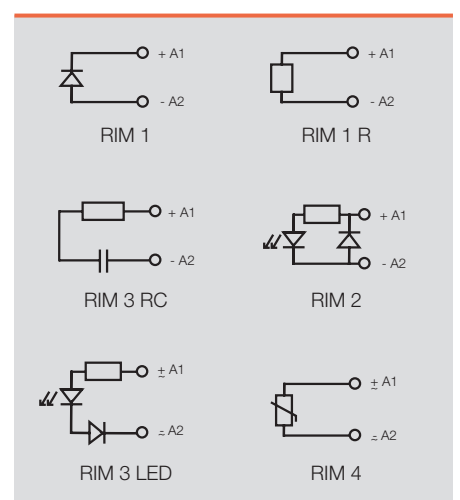
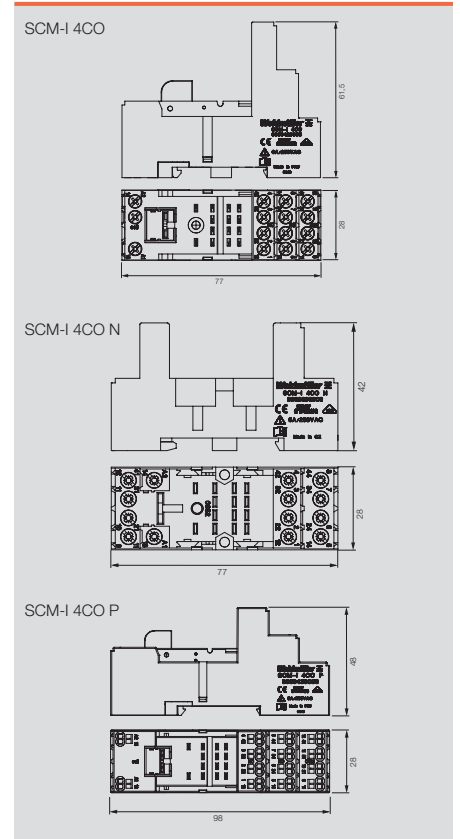

**Relays - RIDERSERIES**

**RCM relay  
2 CO contact  
AC/DC coil**

- 3000 VA switching capacity
- Solder and plug connection
- Safe-to-touch test button, selectable locking
- White labelling panel

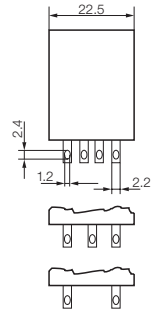

**C**

**Circuit diagram**

View of connections  
Dimensions in mm

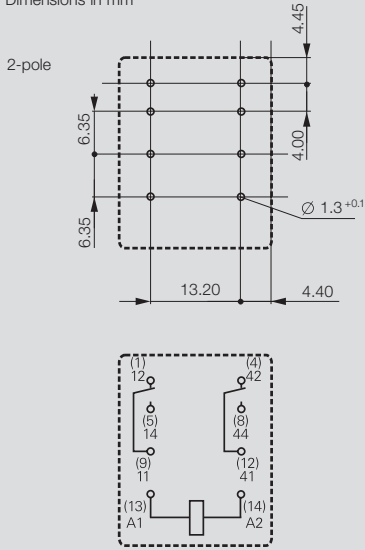

Output	
max. switching voltage AC1	250 V
Continuous current	12 A
Contact base material	AgNi 90/10
Mechanical endurance	AC coil 20*10 <sup>6</sup> / DC coil 30*10 <sup>6</sup> switching operations
Response time / Drop-out time	15ms / 10ms
Rated data	
Status indicator / Free wheel diode	see ordering data
Operating temperature	-40 °C...+70 °C
UL 94 flammability rating	V-0
Approvals	cURus; CE; VDE;
Insulation coordination (IEC 60664)	
Rated voltage	240 V
Creepage and clearance path input - output	≤ 4mm
Surge category	III
Pollution severity	3
Dimensions	
Length x width x height	mm 28 / 22.5 / 29
Note	

**Applications**

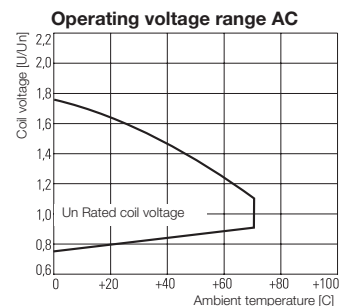
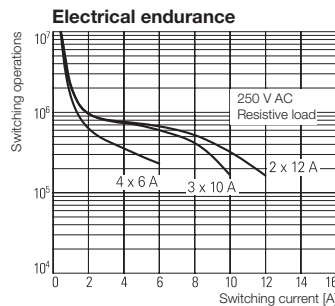
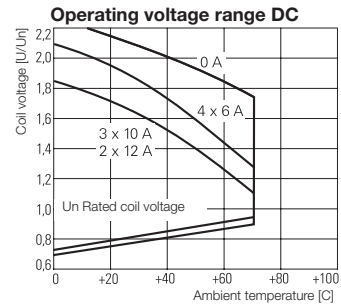
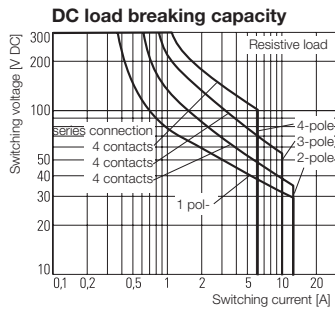

**RCM relay  
2 CO contact  
AC/DC coil**

<b>Type code</b>	RCM				
<b>Type</b>	RIDER Control Multiple				
<b>Contacts</b>	2 2 CO contacts				
	3 3 CO contacts				
	5 4 CO contacts				
<b>Contact material</b>	7 AgNi 90/10, with test button				
	8 AgNi 90/10 hgp, with test button				
<b>Type of construction</b>	0 Standard, 2,8 mm Faston				
<b>DC coil</b>	with LED				
	006 6 V DC	L06			
	012 12 V DC	L12			
	024 24 V DC	L24			
	048 48 V DC	L48			
	060 60 V DC	L60			
	110 110 V DC	M10			
	220 220 V DC	N20			
<b>AC coil</b>					
	506 6 V AC	R06			
	512 12 V AC	R12			
	524 24 V AC	R24			
	548 48 V AC	R48			
	615 115 V AC	S15			
	730 230 V AC	T30			

**Ordering data**

Input	12 V DC 2CO	24 V DC 2CO	48 V DC 2CO	110 V DC 2CO
Rated voltage	12 V DC	24 V DC	48 V DC	110 V DC
DC Response/dropout Volt	9.0 V / 1.2 V	18.0 V / 2.4 V	36.0 V / 4.8 V	82.5 V / 11.0 V
Power rating	750 mW	750 mW	750 mW	750 mW
Rated current DC	62.5 mA	31.3 mA	15.6 mA	6.8 mA
Coil resistance	192 Ω ±10%	777 Ω ±10%	3072 Ω ±10%	16133 Ω ±15%

Ordering data Relay				
without LED Type	RCM270012	RCM270024	RCM270048	RCM270110
AgNi 90/10 Order No.	<b>8689840000</b>	<b>8689860000</b>	<b>8689880000</b>	<b>8689900000</b>
with LED Type	RCM270L12	RCM270L24	RCM270L48	RCM270M10
AgNi 90/10 Order No.	<b>8689850000</b>	<b>8689870000</b>	<b>8689890000</b>	<b>8689910000</b>
Type Order No.				

Note				

**Ordering data**

Input	24 V AC 2CO	48 V AC 2CO	115 V AC 2CO	230 V AC 2CO
Rated voltage	24 V AC	48 V AC	115 V AC	230 V AC
AC Response/dropout Volt	38.4 V / 14.4 V	48.0 V / 18.0 V	92.0 V / 34.5 V	184.0 V / 69.0 V
Power rating	1.0 VA	1.0 VA	1.0 VA	1.0 VA
Rated current AC	41.6 mA	21.3 mA	8.8 mA	4.3 mA
Coil resistance	192 Ω ±10%	777 Ω ±10%	4845 Ω ±12%	19465 Ω ±15%

Ordering data Relay				
without LED Type	RCM270524	RCM270548	RCM270615	RCM270730
AgNi 90/10 Order No.	<b>8689760000</b>	<b>8689780000</b>	<b>8689800000</b>	<b>8689820000</b>
with LED Type	RCM270R24	RCM270R48	RCM270S15	RCM270T30
AgNi 90/10 Order No.	<b>8689770000</b>	<b>8689790000</b>	<b>8689810000</b>	<b>8689830000</b>
Type Order No.				

Note				

Relays - RIDERSERIES

**RCM relay**  
**3 CO contact**  
**AC/DC coil**

- 2500 VA switching capacity
- Solder and plug connection
- Safe-to-touch test button, selectable locking
- White labelling panel



Solder- and plug-in terminals (standard version)

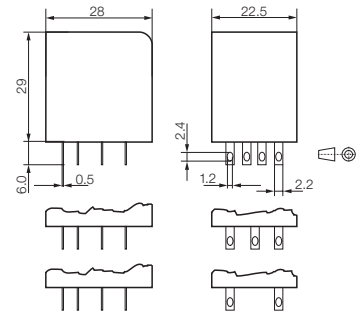

C

**Circuit diagram**  
 View of connections  
 Dimensions in mm

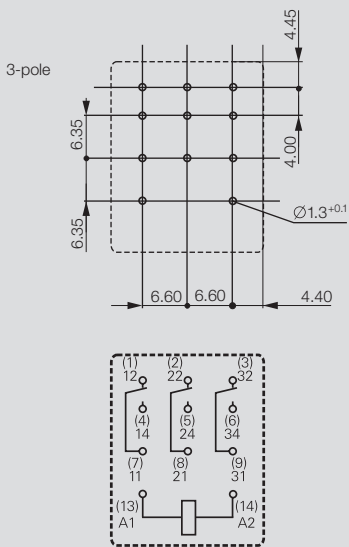

Output	
max. switching voltage AC1	250 V
Continuous current	10 A
Contact base material	AgNi 90/10
Mechanical endurance	AC coil 20*10 <sup>6</sup> / DC coil 30*10 <sup>6</sup> switching operations
Response time / Drop-out time	15ms / 10ms
Rated data	
Status indicator / Free wheel diode	see ordering data
Operating temperature	-40 °C...+70 °C
UL 94 flammability rating	V-0
Approvals	cURus; CE; VDE;
Insulation coordination (IEC 60664)	
Rated voltage	240 V
Creepage and clearance path input - output	≤ 4mm
Surge category	III
Pollution severity	3
Dimensions	
Length x width x height	mm 28 / 22.5 / 29
Note	

Applications

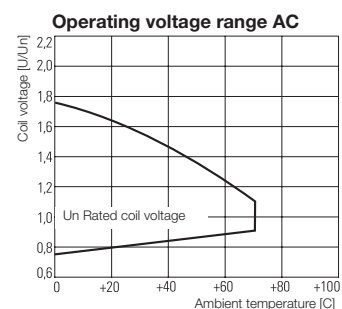
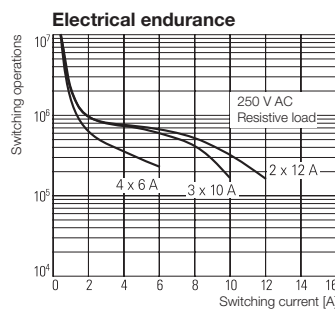
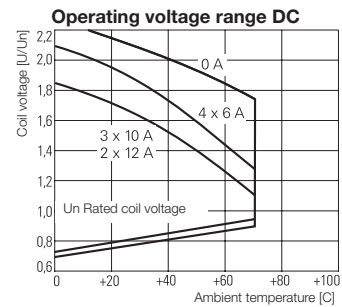
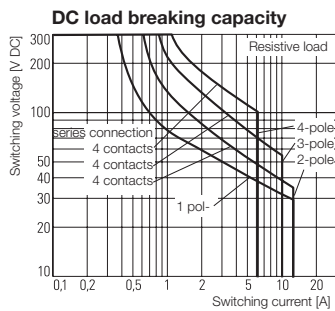

**RCM relay  
3 CO contact  
AC/DC coil**

Type code

<b>RCM</b>				
------------	--	--	--	--

Type **RIDER Control Multiple**

**Contacts**

- 2 2 CO contacts
- 3 3 CO contacts
- 5 4 CO contacts

**Contact material**

- 7 AgNi 90/10, with test button
- 8 AgNi 90/10 hgp, with test button

**Type of construction**

- 0 Standard, 2,8 mm Faston

DC coil		with LED
006	6 V DC	L06
012	12 V DC	L12
024	24 V DC	L24
048	48 V DC	L48
060	60 V DC	L60
110	110 V DC	M10
220	220 V DC	N20
AC coil		
506	6 V AC	R06
512	12 V AC	R12
524	24 V AC	R24
548	48 V AC	R48
615	115 V AC	S15
730	230 V AC	T30

**Ordering data**

Input	12 V DC 3CO	24 V DC 3CO	48 V DC 3CO	110 V DC 3CO
Rated voltage	12 V DC	24 V DC	48 V DC	110 V DC
DC Response/dropout Volt	9.0 V / 1.2 V	18.0 V / 2.4 V	36.0 V / 4.8 V	82.5 V / 11.0 V
Power rating	750 mW	750 mW	750 mW	750 mW
Rated current DC	62.5 mA	31.3 mA	15.6 mA	6.8 mA
Coil resistance	192 Ω ±10%	777 Ω ±10%	3072 Ω ±10%	16133 Ω ±15%

Ordering data Relay				
without LED Type	RCM370012	RCM370024	RCM370048	RCM370110
AgNi 90/10 Order No.	<b>8690020000</b>	<b>8690040000</b>	<b>8690060000</b>	<b>8690080000</b>
with LED Type	RCM370L12	RCM370L24	RCM370L48	RCM370M10
AgNi 90/10 Order No.	<b>8694310000</b>	<b>8690050000</b>	<b>8689940000</b>	<b>8690090000</b>
Type Order No.				

Note				

**Ordering data**

Input	24 V AC 3CO	48 V AC 3CO	115 V AC 3CO	230 V AC 3CO
Rated voltage	24 V AC	48 V AC	115 V AC	230 V AC
AC Response/dropout Volt	19.2 V / 7.2 V	38.4 V / 14.4 V	92.0 V / 34.5 V	184.0 V / 69.0 V
Power rating	1.0 VA	1.0 VA	1.0 VA	1.0 VA
Rated current AC	41.6 mA	21.3 mA	8.8 mA	4.3 mA
Coil resistance	192 Ω ±10%	777 Ω ±10%	4845 Ω ±12%	19465 Ω ±15%

Ordering data Relay				
without LED Type	RCM370524	RCM370548	RCM370615	RCM370730
AgNi 90/10 Order No.	<b>8690030000</b>	<b>8689960000</b>	<b>8689980000</b>	<b>8690000000</b>
with LED Type	RCM370R24	RCM370R48	RCM370S15	RCM370T30
AgNi 90/10 Order No.	<b>8689950000</b>	<b>8689970000</b>	<b>8689990000</b>	<b>8690010000</b>
Type Order No.				

Note				

Relays - RIDERSERIES

**RCM relay**  
**4 CO contact**  
**AC/DC coil**

- 1500 VA switching capacity
- Solder and plug connection
- AC/DC versions also with gold-plated contacts
- Safe-to-touch test button, selectable locking
- White labelling panel

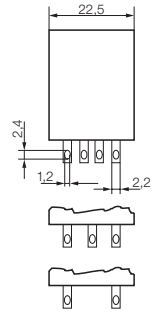

C

**Circuit diagram**  
 View of connections  
 Dimensions in mm

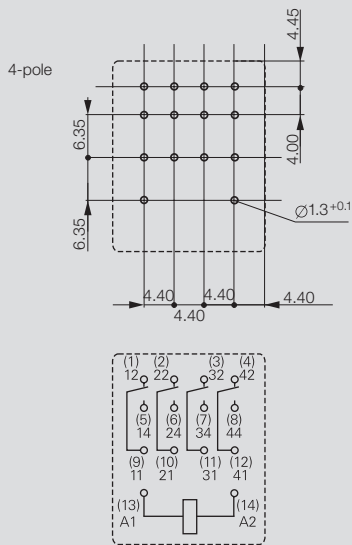

Output	
max. switching voltage AC1	250 V
Continuous current	6 A
Contact base material	AgNi 90/10 or AgNi 5µm Au
Mechanical endurance	AC coil 20°10' / DC coil 30°10' switching operations
Response time / Drop-out time	15ms / 10ms
Rated data	
Status indicator / Free wheel diode	see ordering data
Operating temperature	-40 °C...+70 °C
UL 94 flammability rating	V-0
Approvals	cURus; CE; VDE;
Insulation coordination (IEC 60664)	
Rated voltage	240 V
Creepage and clearance path input - output	≤ 3mm
Surge category	III
Pollution severity	2
Dimensions	
Length x width x height	mm 28 / 22.5 / 29
Note	

Applications

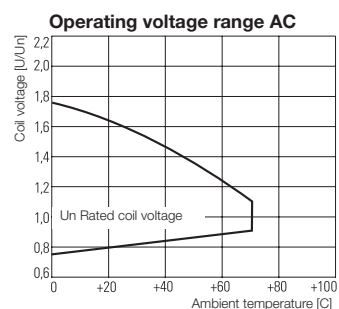
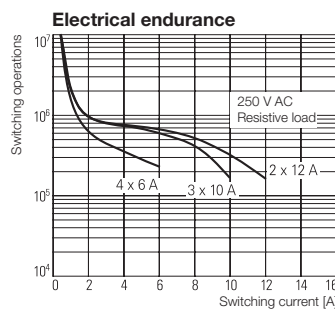
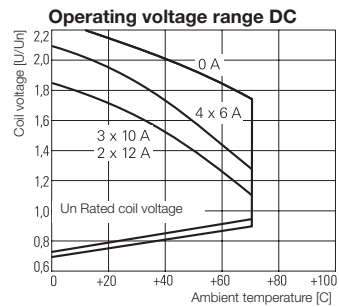
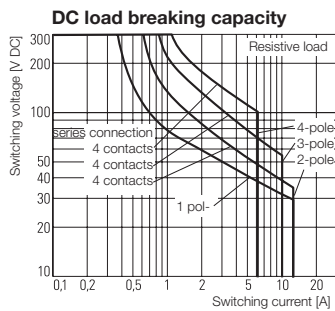

**RCM relay  
4 CO contact  
AC/DC coil**

<b>Type code</b>	RCM				
<b>Type</b>	RIDER Control Multiple				
<b>Contacts</b>	2 2 CO contacts				
	3 3 CO contacts				
	5 4 CO contacts				
<b>Contact material</b>	7 AgNi 90/10, with test button				
	8 AgNi 90/10 hgp, with test button				
<b>Type of construction</b>	0 Standard, 2,8 mm Faston				

<b>DC coil</b>	with LED
006	6 V DC L06
012	12 V DC L12
024	24 V DC L24
048	48 V DC L48
060	60 V DC L60
110	110 V DC M10
220	220 V DC N20
<b>AC coil</b>	
506	6 V AC R06
512	12 V AC R12
524	24 V AC R24
548	48 V AC R48
615	115 V AC S15
730	230 V AC T30

**Ordering data**

Input	12 V DC 4CO	24 V DC 4CO	48 V DC 4CO	110 V DC 4CO
Rated voltage	12 V DC	24 V DC	48 V DC	110 V DC
DC Response/dropout Volt	9,0 V / 1,2 V	18 V / 2,4 V	36 V / 4,8 V	82,5 V / 11 V
Power rating	750 mW	750 mW	750 mW	750 mW
Rated current DC	62,5 mA	31,3 mA	15,6 mA	6,8 mA
Coil resistance	192 Ω ±10%	777 Ω ±10%	3072 Ω ±10%	16133 Ω ±15%

Ordering data Relay	12 V DC 4CO	24 V DC 4CO	48 V DC 4CO	110 V DC 4CO
without LED Type	RCM570012	RCM570024	RCM570048	RCM570110
AgNi 90/10 Order No.	<b>8054360000</b>	<b>8690200000</b>	<b>8074670000</b>	<b>8074700000</b>
with LED Type	RCM570L12	RCM570L24	RCM570L48	RCM570M10
AgNi 90/10 Order No.	<b>8690180000</b>	<b>8690220000</b>	<b>8690230000</b>	<b>8690240000</b>
without LED Type	RCM580012	RCM580024	RCM580048	RCM580110
AgNi 5µm Au Order No.	<b>on request</b>	<b>8694460000</b>	<b>on request</b>	<b>8829000000</b>

Note	12 V DC 4CO	24 V DC 4CO	48 V DC 4CO	110 V DC 4CO

**Ordering data**

Input	24 V AC 4CO	48 V AC 4CO	115 V AC 4CO	230 V AC 4CO
Rated voltage	24 V AC	48 V AC	115 V AC	230 V AC
AC Response/dropout Volt	19,2 V / 7,2 V	38,4 V / 14,4 V	92 V / 34,5 V	184 V / 69 V
Power rating	1,0 VA	1,0 VA	1,0 VA	1,0 VA
Rated current AC	41,6 mA	21,3 mA	8,8 mA	4,3 mA
Coil resistance	192 Ω ±10%	777 Ω ±10%	4845 Ω ±12%	19465 Ω ±15%

Ordering data Relay	24 V AC 4CO	48 V AC 4CO	115 V AC 4CO	230 V AC 4CO
without LED Type	RCM570524	RCM570548	RCM570615	RCM570730
AgNi 90/10 Order No.	<b>8690110000</b>	<b>1180900000</b>	<b>1180800000</b>	<b>1181100000</b>
with LED Type	RCM570R24	RCM570R48	RCM570S15	RCM570T30
AgNi 90/10 Order No.	<b>8690120000</b>	<b>8690130000</b>	<b>8690150000</b>	<b>8690160000</b>
without LED Type	RCM580524		RCM580615	RCM580730
AgNi 5µm Au Order No.	<b>7940008171</b>		<b>8824860000</b>	<b>7940007637</b>

Note	24 V AC 4CO	48 V AC 4CO	115 V AC 4CO	230 V AC 4CO

**Relays - RIDERSERIES**

**RRD relay  
2 CO contact  
AC/DC coil**

- 2 change-over contacts
- 2500 VA switching capacity
- Mechanical operating indicator
- Safe-to-touch test button, selectable locking

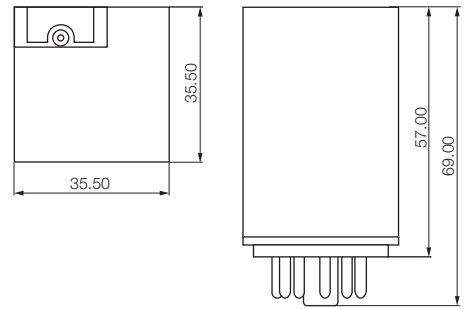

**C**

**Circuit diagram**  
View of connections

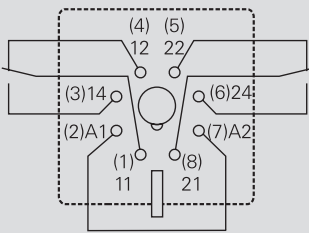

Output	
max. switching voltage AC1	250 V
Continuous current	10 A
Contact base material	AgNi 90/10
Mechanical endurance	20*10 <sup>6</sup> switching cycles
Response time / Drop-out time	12 ms / 5 ms
Rated data	
Status indicator/Free wheel diode	mechanical/no
Operating temperature	-45 °C...+50 °C
UL 94 flammability rating	V-0
Approvals	cURus; CE; VDE;
Insulation coordination (IEC 60664)	
Rated voltage	250 V
Creepage and clearance path input - output	≤ 4mm
Surge category	III
Pollution severity	3
Dimensions	
Length x width x height	mm 35.5 / 35.5 / 57
Note	

**Applications**

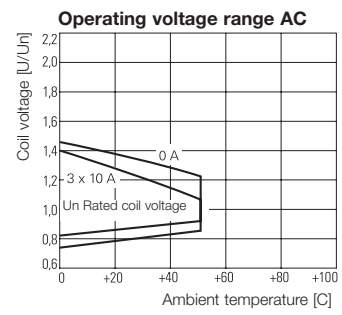
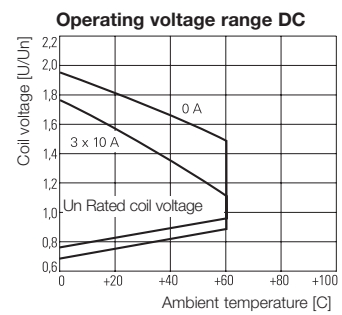
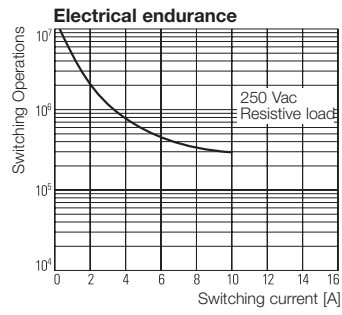
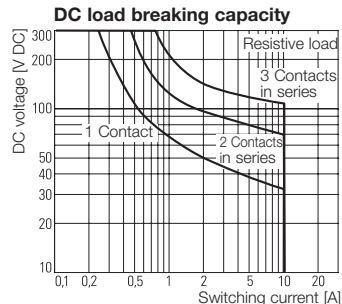

**RRD relay  
2 CO contact  
AC/DC coil**

<b>Type code</b>	RRD						
<b>Type</b>	RIDER Round						
<b>Contacts</b>	2 2 change-over contacts, 8-pole 3 3 change-over contacts, 11-pole						
<b>Contact material</b>	2 AgNi 90/10						
<b>Type of construction</b>	1 DC coil with test button 3 DC coil with test button and bi-polar LED 6 AC coil with test button 8 AC coil with test button and bi-polar LED						
<b>DC coil</b>							Free wheel diode
006	6 V DC						
012	12 V DC						
024	24 V DC						0C4
048	48 V DC						0E8
060	60 V DC						0G0
110	110 V DC						1B0
220	220 V DC						2C0
<b>AC coil</b>							
006	6 V AC						
012	12 V AC						
024	24 V AC						
048	48 V AC						
115	115 V AC						
230	230 V AC						

**Ordering data**

Input	24 V DC 2CO	48 V DC 2CO	110 V DC 2CO	220 V DC 2CO
Rated voltage	24 V DC	48 V DC	110 V DC	220 V DC
DC Response/dropout Volt	18.0 V / 2.4 V	36.0 V / 4.8 V	82.5 V / 11.5 V	165 V / 22 V
Power rating	1.2 W	1.2 W	1.2 W	1.2 W
Rated current DC	50.5 mA	24.0 mA	11.0 mA	5.5 mA
Coil resistance	475 Ω ±10%	2000 Ω ±10%	10000 Ω ±12%	40000 Ω ±15%

Ordering data Relay	24 V DC 2CO	48 V DC 2CO	110 V DC 2CO	220 V DC 2CO
with test button Type	RRD221024	RRD221048	RRD221110	
AgNi 90/10 Order No.	<b>8690370000</b>	<b>8690390000</b>	<b>8690410000</b>	
with test button/LED Type	RRD223024	RRD223048	RRD223110	RRD223220
AgNi 90/10 Order No.	<b>8690380000</b>	<b>8690400000</b>	<b>8690420000</b>	<b>8798600000</b>
Type Order No.				

Note	24 V DC 2CO	48 V DC 2CO	110 V DC 2CO	220 V DC 2CO

**Ordering data**

Input	24 V AC 2CO	48 V AC 2CO	115 V AC 2CO	230 V AC 2CO
Rated voltage	24 V AC	48 V AC	115 V AC	230 V AC
AC Response/dropout Volt	19.2 V / 9.6 V	38.4 V / 19.2 V	92.0 V / 46.0 V	184.0 V / 92.0 V
Power rating	2.3 VA	2.3 VA	2.3 VA	2.3 VA
Rated current AC	94.2 mA	47.5 mA	20.6 mA	10.1 mA
Coil resistance	86 Ω ±10%	345 Ω ±10%	2000 Ω ±10%	8300 Ω ±12%

Ordering data Relay	24 V AC 2CO	48 V AC 2CO	115 V AC 2CO	230 V AC 2CO
with test button Type	RRD226024	RRD226048	RRD226115	RRD226230
AgNi 90/10 Order No.	<b>8690270000</b>	<b>8690290000</b>	<b>8690310000</b>	<b>8690330000</b>
with test button/LED Type	RRD228024	RRD228048	RRD228115	RRD228230
AgNi 90/10 Order No.	<b>8690280000</b>	<b>8690300000</b>	<b>8690320000</b>	<b>8690340000</b>
Type Order No.				

Note	24 V AC 2CO	48 V AC 2CO	115 V AC 2CO	230 V AC 2CO

**Relays - RIDERSERIES**

**RRD relay  
3 CO contact  
AC/DC coil**

- 3 change-over contacts
- 500 VA switching capacity
- Mechanical operating indicator
- Safe-to-touch test button, selectable locking

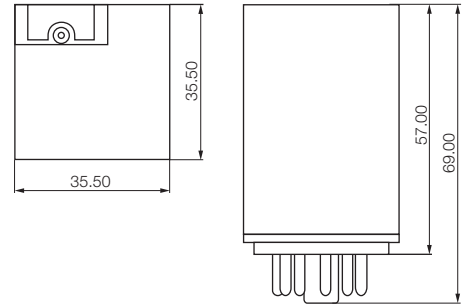

**C**

**Circuit diagram**  
View of connections

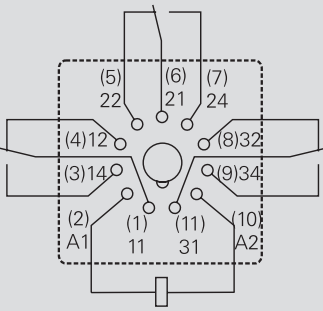

Output	
max. switching voltage AC1	250 V
Continuous current	10 A
Contact base material	AgNi 90/10
Mechanical endurance	20*10 <sup>6</sup> switching cycles
Response time / Drop-out time	12 ms / 5 ms
Rated data	
Status indicator/Free wheel diode	mechanical/
Operating temperature	AC coil -45...+50°C / DC coil -45...+60°C
UL 94 flammability rating	V-0
Approvals	cURus; CE; VDE;
Insulation coordination (IEC 60664)	
Rated voltage	250 V
Creepage and clearance path input - output	≤ 4mm
Surge category	III
Pollution severity	3
Dimensions	
Length x width x height	mm 35.5 / 35.5 / x
Note	

**Applications**

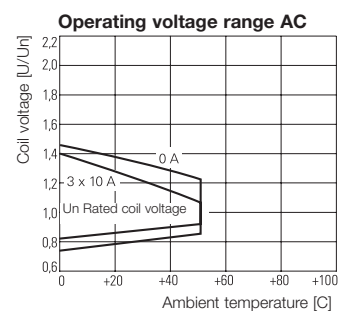
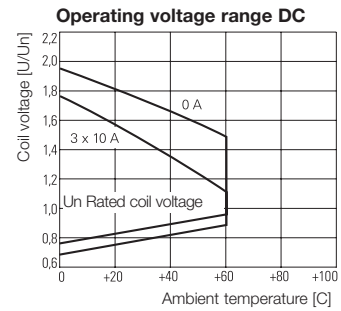
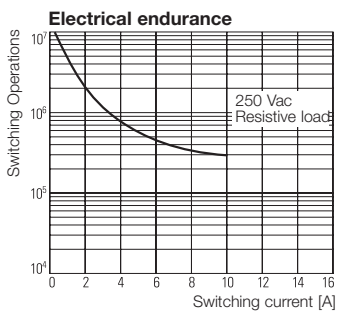
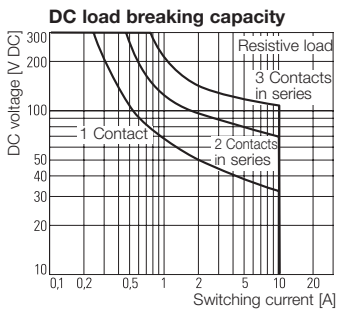

**RRD relay  
3 CO contact  
AC/DC coil**

<b>Type code</b>	RRD						
<b>Type</b>	RIDER Round						
<b>Contacts</b>	2 2 change-over contacts, 8-pole 3 3 change-over contacts, 11-pole						
<b>Contact material</b>	2 AgNi 90/10						
<b>Type of construction</b>	1 DC coil with test button 3 DC coil with test button and bi-polar LED 6 AC coil with test button 8 AC coil with test button and bi-polar LED						
<b>DC coil</b>	006	6 V DC					Free wheel diode
	012	12 V DC					
	024	24 V DC				0C4	
	048	48 V DC				0E8	
	060	60 V DC				0G0	
	110	110 V DC				1B0	
	220	220 V DC				2C0	
<b>AC coil</b>	006	6 V AC					
	012	12 V AC					
	024	24 V AC					
	048	48 V AC					
	115	115 V AC					
	230	230 V AC					

**Ordering data**

Input	12 V DC 3CO	24 V DC 3CO	110 V DC 3CO	220 V DC 3CO
Rated voltage	12 V DC	24 V DC	110 V DC	220 V DC
DC Response/dropout Volt	9 V / 1.2 V	18 V / 2.4 V	82.5 V / 11.5 V	165 V / 22 V
Power rating	1.2 W	1.2 W	1.2 W	1.2 W
Rated current DC	109.1 mA	50.5 mA	11 mA	5.5 mA
Coil resistance	110 Ω ±10%	475 Ω ±10%	10000 Ω ±12%	40000 Ω ±15%

Ordering data Relais	12 V DC 3CO	24 V DC 3CO	110 V DC 3CO	220 V DC 3CO
with test button Type	RRD321012	RRD321024	RRD321110	RRD321220
Order No.	<b>8799030000</b>	<b>8690610000</b>	<b>8690650000</b>	<b>7940007742</b>
with test button/LED Type		RRD323024	RRD323110	RRD323220
Order No.		<b>8690620000</b>	<b>8690660000</b>	<b>8798610000</b>
with test button Type		RRD3210C4	RRD3211B0	RRD3212CO
+ Free-wheel diode Order No.		<b>8797650000</b>	<b>8797640000</b>	<b>8797610000</b>
with test button/LED Type		RRD3230C4		RRD3232CO
+ Free-wheel diode Order No.		<b>7940007732</b>		<b>8829400000</b>
<b>Note</b>				

**Ordering data**

Input	24 V AC 3CO	48 V AC 3CO	115 V AC 3CO	230 V AC 3CO
Rated voltage	24 V AC	48 V AC	115 V AC	230 V AC
AC Response/dropout Volt	19.2 V / 9.6 V	38.4 V / 19.2 V	92 V / 46 V	184 V / 92 V
Power rating	2.3 VA	2.3 VA	2.3 VA	2.3 VA
Rated current AC	94.2 mA	47.5 mA	20.6 mA	10.1 mA
Coil resistance	86 Ω ±10%		2000 Ω ±10%	8300 Ω ±12%

Ordering data Relais	24 V AC 3CO	48 V AC 3CO	115 V AC 3CO	230 V AC 3CO
with test button Type	RRD326024	RRD326048	RRD326115	RRD326230
Order No.	<b>8690450000</b>	<b>8690470000</b>	<b>8690550000</b>	<b>8690570000</b>
with test button/LED Type	RRD328024	RRD328048	RRD328115	RRD328230
Order No.	<b>8690460000</b>	<b>8690480000</b>	<b>8690560000</b>	<b>8690580000</b>
Type				
Order No.				
Type				
Order No.				
<b>Note</b>				

## Relays - RIDERSERIES

### Accessories for RRD relays Plug-in module with screw connection



### Dimensions in mm

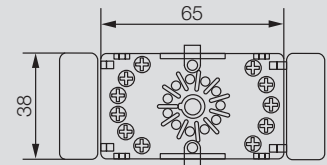
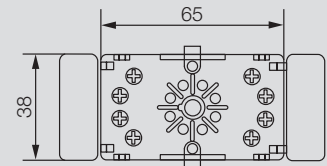
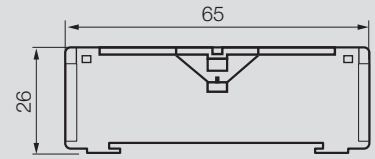

### Ordering data

Description	Type	Qty	Order No.
Plug-in module with screw connections, 8-pole	SRD-I 2CO	10	8869360000
Plug-in module with screw connections, 11-pole	SRD-I 3CO	10	8869350000

Contact data	
Nominal current	10 A
Nominal voltage	400 V AC
Dielectric strength, coil/contacts	>2500 Veff
Ambient temperature	-20 °C ... + 80 °C
Ingress protection class (IEC 61810)	IP 20
Conductor cross-section / with wire end ferrule	2 x 2.5 mm <sup>2</sup> / 2 x 1.5 mm <sup>2</sup>
Terminal torque	0.5 / 0.7 Nm

### Retaining clip (metal)

Ordering data		
Accessories for		
Description	Type	Order No.
Metal retaining clip, RRD	SRD-I CLIP M	8869370000



**Relays - RIDERSERIES**

**RPW relay**  
**2 CO contact AC/DC coil**  
**3 CO contact AC/DC coil**

- 6000 VA switching capacity
- Mechanical indicator
- with and without test button

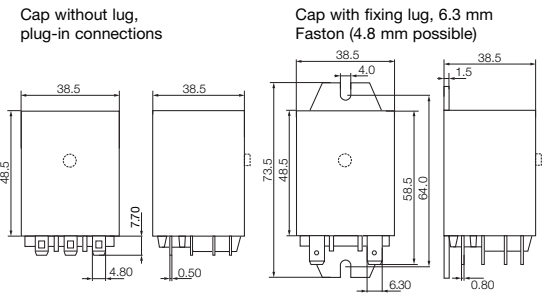

**C**

**Circuit diagram**

View of connections

**2 changeover contacts**

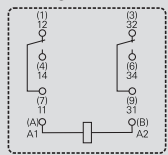

**3 changeover contacts**

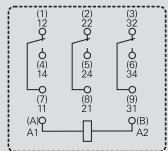

**Output**

max. switching voltage AC1	400 V
Continuous current	16 A
Contact base material	AgCdO
Mechanical endurance	20*10 <sup>6</sup> switching cycles
Response time / Drop-out time	15 ms / 10 ms

**Rated data**

Status indicator/Free wheel diode	mechanical/no
Operating temperature	-45 °C...+70 °C
UL 94 flammability rating	V-0
Approvals	cURus; CE; VDE;

**Insulation coordination (IEC 60664)**

Rated voltage	400 V
Creepage and clearance path input - output	≤ 6mm
Surge category	III
Pollution severity	3

**Dimensions**

Length x width x height	mm	38.5 / 38.5 / 48.5
-------------------------	----	--------------------

**Note**

**Applications**

**DC load breaking capacity**

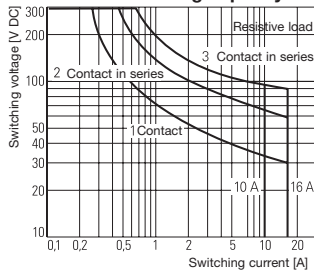

**Operating voltage range DC**

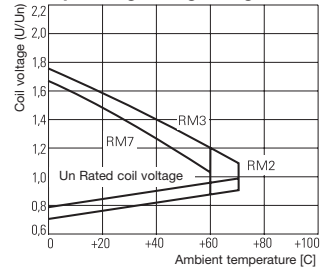

**Electrical endurance**

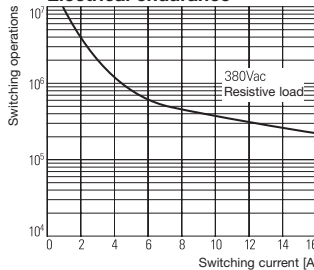

**Operating voltage range AC**

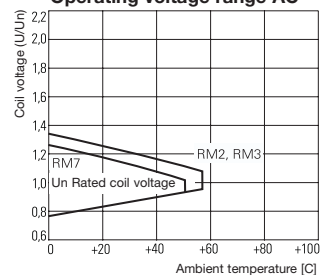

**RPW relay**  
**2 CO contact AC/DC coil**  
**3 CO contact AC/DC coil**

Type code	RPW				
Typ	RIDER PoWer				
Contacts	2 2 change-over contacts 7 3 change-over contacts				
Type of construction	0 Without test button 3 With test button				
Housing	2 Cap without lug, 4.8 mm Faston 5 Cap with lug, 6.3 mm Faston				
DC coil	006	6 V DC			
	012	12 V DC			
	024	24 V DC			
	048	48 V DC			
	060	60 V DC			
	110	110 V DC			
AC coil	506	6 V AC			
	512	12 V AC			
	524	24 V AC			
	548	48 V AC			
	615	115 V AC			
	730	230 V AC			

**Ordering data**

Input	24 V DC 2CO	24 V AC 2CO	230 V AC 2CO	
Rated voltage	24 V DC	24 V AC	230 V AC	
DC Response/dropout Volt	18 V / 2.4 V	19.2 V / 9.6 V	184 V / 92 V	
Power rating	1.2 W	2.3 VA	2.3 VA	
Rated current DC	50.5 mA	94.2 mA	10.1 mA	
Coil resistance	475 Ω ±10%	86 Ω ±10%	8300 Ω ±12%	

Ordering data Relay				
without test button Type	RPW202024	RPW202524	RPW202730	
AgCdO Order No.	<b>8690730000</b>	<b>on request</b>	<b>8690720000</b>	
Type Order No.				
Type Order No.				

Note				

**Ordering data**

Input	24 V DC 3CO	24 V AC 3CO	230 V AC 3CO	
Rated voltage	24 V DC	24 V AC	230 V AC	
DC Response/dropout Volt	18 V / 2.4 V	19.2 V / 9.6 V	184 V / 92 V	
Power rating	1.6 W	2.8 VA	2.8 VA	
Rated current DC	69.6 mA	109.2 mA	11.7 mA	
Coil resistance	345 Ω ±10%	80 Ω ±10%	7500 Ω ±10%	

Ordering data Relay				
without test button Type	RPW702024	RPW702524	RPW702730	
AgCdO Order No.	<b>8690760000</b>	<b>8690740000</b>	<b>8690750000</b>	
Type Order No.				
Type Order No.				

Note				

## Relays - RIDERSERIES

### Accessories for RPW Plug-in module with screw connection



### Dimensions in mm

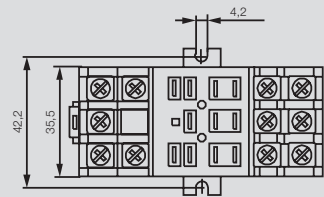
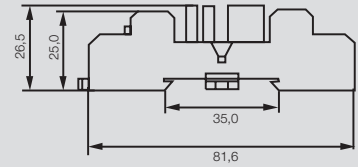

### Ordering data

Description	Type	Qty	Order No.
Plug-in module with screw connections	SPW 3CO	25	8697680000
<b>Contact data</b>			
Nominal current	16 A		
Nominal voltage	250 V AC		
Dielectric strength, coil/contacts	>2500 Vms		
Ambient temperature	-40 °C ... +40 °C		
Terminal torque	0.8 Nm		
Max.	1.2 Nm		

**Plug-in socket with PCB connections**  
for RCL relays

**Ordering data**

Description	
Plug-in socket with PCB connections, pinning 3.5 mm	
Plug-in socket with PCB connections, pinning 5 mm	
Accessory: metal retaining clip, 15.7 mm high	
Accessory: metal retaining clip, 25.5 mm high	
Technical data	
Nominal current	1-pole
	2-pole
Nominal voltage	
Ambient temperature	
Approvals	



Type	Qty	Order No.
SRC 1CO PCB	100	8690860000
SRC 2CO PCB	100	8690850000
SRC CLIP LM		8693810000
SRC CLIP HM		8692620000
Technical data		
	12 A	
	2 x 12 A	
	300 V AC	
	-40 °C ... +80 °C	
		

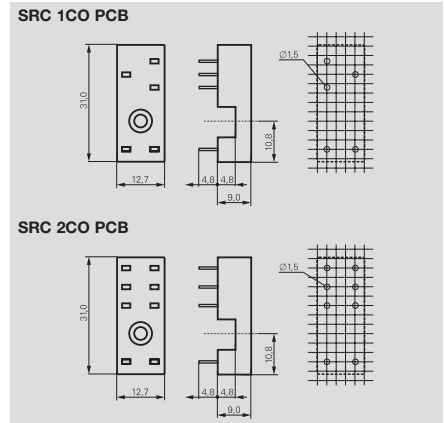

**Plug-in socket with solder/PCB connections**  
for RCM relays

**Ordering data**

Description	
Plug-in socket with solder connections, 4-pole	
Plug-in socket with PCB connections, 2-pole	
Plug-in socket with PCB connections, 3-pole	
Plug-in socket with PCB connections, 4-pole	
Accessory: metal retaining clip, 29 mm high	
Technical data	
Nominal current	
Nominal voltage	
Ambient temperature	
Approvals	



Type	Qty	Order No.
SCM 4CO PCB	25	8697610000
SCM 2CO PCB	25	8697620000
SCM 3CO PCB	25	8697640000
SCM 4CO PCB	25	8697660000
SRM CLIP LM		8694400000
Technical data		
	10 A	
	250 V AC	
	-40 °C ... +80 °C	
		

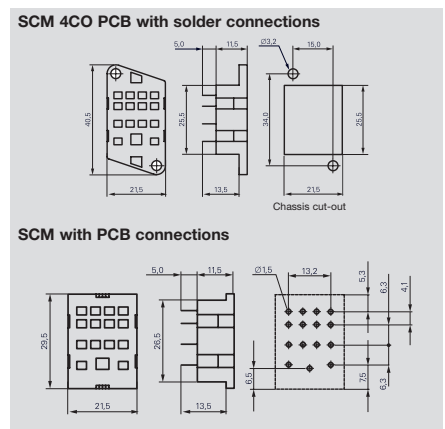

**Plug-in socket with PCB connections**  
for RRD relays

**Ordering data**

Description	
Plug-in socket with solder and PCB connections	8-pole
Plug-in socket with solder and PCB connections	11-pole
Technical data	
Nominal current	
Nominal voltage	
Ambient temperature	



Type	Qty	Order No.
SRD 2CO PCB	25	8697750000
SRD 3CO PCB	25	8697730000
Technical data		
	10 A	
	250 V A-C	
	-40 °C ... +70 °C	

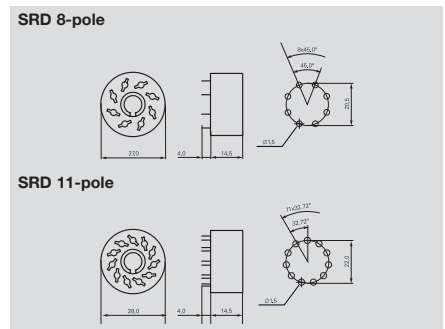

**Plug-in socket with PCB connections**  
for RPW relays

**Ordering data**

Description	
Plug-in socket with PCB connections	
Accessory: metal retaining clip, RPW	
Technical data	
Approvals	



Type	Qty	Order No.
SPW 3CO PCB		8697710000
SPW CLIP M		8697780000
		

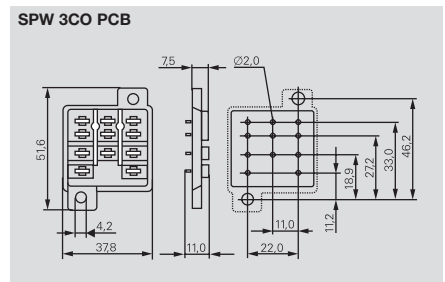

Relays – RS-SERIES – RS 30

1 NCC, 1 NOC  
or 1 change-over contact

RS 30

Screw connection

1 NOC  
1 NCC



1 change-over contact



RS 30

Isolating plug with screw connection

1 NOC  
1 NCC



1 change-over contact



Technical data

Input voltage 5 ... 60 V ± 10 %; 115 V/230 V + 5 % – 15 %

Nominal consumption – (W)
Nominal consumption ~ (VA)
Drop-out current of relay (at 20 °C)
Drop-out current of relay (at 20 °C)
Pick-up current
Output voltage max.
Continuous current

Derating curve  
a = fitted on mounting rail in horizontal row without spacing  
b = fitted on mounting rail in horizontal row with 20 mm spacing

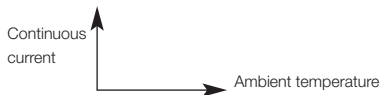

5 VTTL	12 V~	24 V~	24 V=	48 V~	48 V=	60 V~	115 V~	115 V~	230 V~ <sup>2)</sup>	240 V~
0.45 W <sup>1)</sup>	0.45 W	0.45 W	0.45 W	0.45 W	0.45 W	0.45 W	–	0.82 W	–	–
–	–	–	0.7 VA	–	0.6 VA	–	0.8 VA	–	0.8 VA	1.2 VA
–	3 mA	3 mA	2.5 mA~	2 mA	2.5 mA~	1 mA~	–	2 mA~	–	0.5 mA~
–	–	–	3.5 mA~	–	4.5 mA~	–	1 mA~	–	1 mA~	1 mA~
–	–	12 mA	–	10 mA	–	–	6 mA	4.3 mA	–	–
250 V	250 V	250 V	250 V	250 V	250 V	250 V	250 V	250 V	250 V	250 V
5 A	6 A	6 A	6 A	6 A	5 A	5 A	5 A	5 A	3 A	3 A

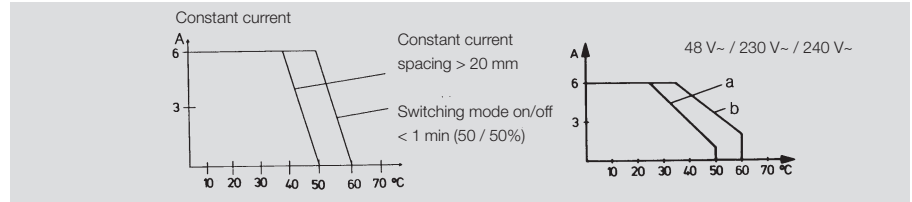

Making current
Making power under ohmic load
Min. switching power/switching current
Duration of bounce
Typical switching times
–, Pick-up delay
–, Drop-out delay
Max. switching frequency
Contact material
Service life, mechanical
–, 24 V-, 1A ohmic load
–, 230 V-, 3A, ohmic load
Storage temperature
Ambient temperature, fitted on mounting rail
–, in horizontal row without spacing
–, in horizontal row with > 20 mm spacing

8 A										
2000 VA / 100 W										
250 mW / 10 mA										
≤ 3 ms										
≤ 8 ms	≤ 8 ms	≤ 8 ms	≤ 8 ms	≤ 12 ms	≤ 13 ms	≤ 12 ms	≤ 9 ms	≤ 12 ms	≤ 10 ms	≤ 10 ms
≤ 7 ms	≤ 7 ms	≤ 7 ms	≤ 16 ms	≤ 11 ms	≤ 12 ms	≤ 11 ms	≤ 8 ms	≤ 11 ms	≤ 9 ms	≤ 9 ms
70 Hz	70 Hz	70 Hz	30 Hz	70 Hz	20 Hz	70 Hz	30 Hz	70 Hz	30 Hz	30 Hz
AgNi, gold-flashed										
> 10 <sup>7</sup> switching cycles										
> 5 x 10 <sup>5</sup> switching cycles										
> 7 x 10 <sup>5</sup> switching cycles										
–40 °C ... +60 °C										
–25 °C ... +40 °C										
–25 °C ... +50 °C										

Insulation coordination to EN 50178

Surge category
Pollution severity

III
2

Dimensions

Mounting width
Length (at 90° to mounting rail)
Height (with TS 32 / TS 35 x 7.5)

11.2 mm NOC / NCC, 25 mm change-over contact
70 mm (74 mm BL/SL version)
56 mm / 51.5 mm

1) Rated consumption of auxiliary voltage 24 V~  
2) 230 V~ on request

RS 30

RS 30

Screw connection

Isolating plug with screw connection

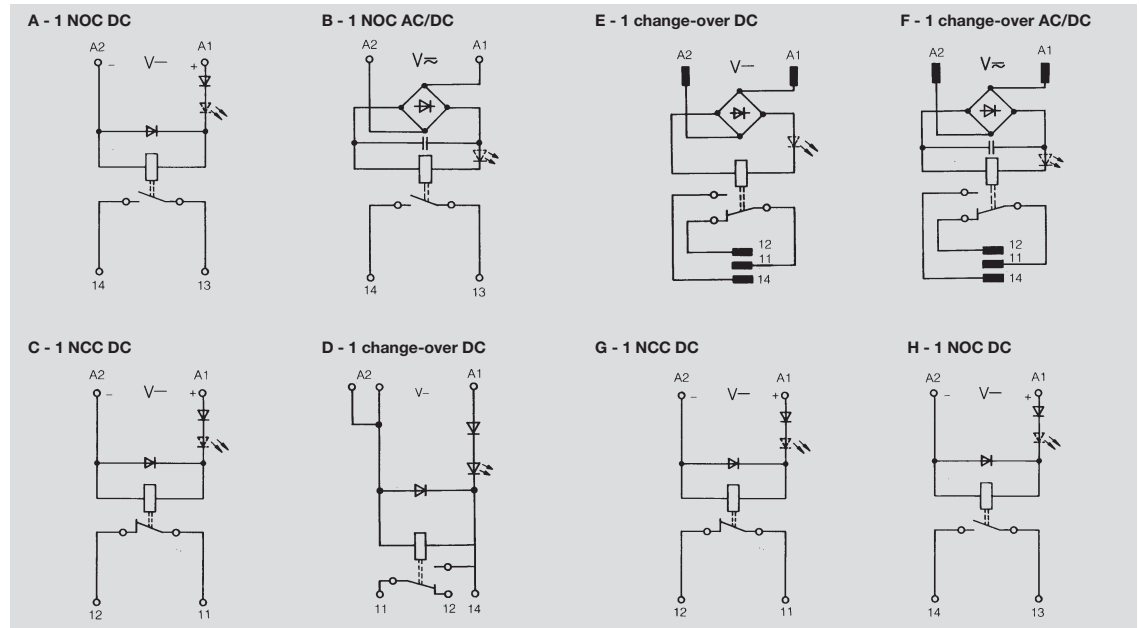

Ordering data

Wiring diagram	
Input voltage	Function indicator
5 V <sub>-</sub> , TTL	without
12 V <sub>-</sub>	without LED red
24 V <sub>-</sub>	without LED green LED red
24 V <sub>≈</sub>	without LED green LED red
48 V <sub>-</sub>	without LED green LED red
48 V <sub>≈</sub>	without LED green
60 V <sub>-</sub>	without LED red
115 V <sub>-</sub>	without LED green LED red
115 V <sub>≈</sub>	without LED green LED red
230 V <sub>-</sub>	without LED green LED red
240 V <sub>-</sub>	LED green LED red

A	B	C	D
NOC	NOC	NCC	change-over
1129421001		1129521001	
1101661001		1100961001	
1101611001		1100911001	1181511001
1101621001		1100921001	1181521001
	1101761001		
	1101711001		
	1101721001		
1101861001			
1101811001			
1101821001			
	1101911001		
1102061001			
1155161001			
1155111001		1155211001	
1155121001		1155221001	
	1102111001		
	1102121001		
	1102261001		
	1102211001		
	1102221001		
	1128511001		
	1128521001		

E	F	G	H
change-over	change-over	NOC	NCC
		1167660000	1167760000
	1129660000		
1100260000			
1100210000			
1100220000			
	1100360000		
1100410000			
1100420000			
	1100560000		
	1100620000		
	1100760000		
	1100860000		

## Relays - RS-SERIES - RS 31

### 1 change-over contact AC/DC/UC coil

- For high switching capacity
- Suitable for switching inductive loads



C

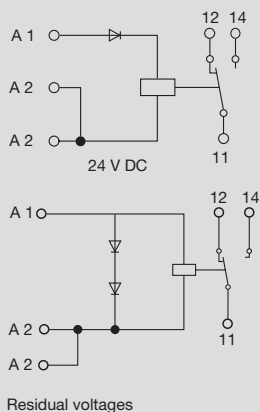

#### Output

max. switching voltage AC1/Continuous current	250 V/16 A
min. switching power	1 W
Response time / Drop-out time	9ms/10ms
Contact base material	AgCdO
Mechanical endurance	3*10 <sup>7</sup> switching cycles
max. switching frequency at rated load	0.1 Hz

#### Rated data

Status indicator/Free wheel diode	LED red/Yes
Reverse pol. prot	available
Operating temperature	-25 °C...+40 °C
Storage temperature	-40 °C...+60 °C
Humidity	40°C/93% RH, no condensation
Approvals	CE;

#### Insulation coordination (EN 50178)

Standards	EN 50178
Rated voltage	250 V
Impulse withstand voltage	6 kV
Creepage and clearance path input - output	3 mm
Surge category	III
Pollution severity	2
Protective separation to VDE 0106 part 101	no

#### Dimensions

	Screw connection	Tension clamp connection
Clamping range (rating- / min. / max.)	mm <sup>2</sup> 2.5 / 0.5 / 4	
Length x width x height	mm 70 / 25 / 53.5	

#### Note

## Applications

### Derating curve

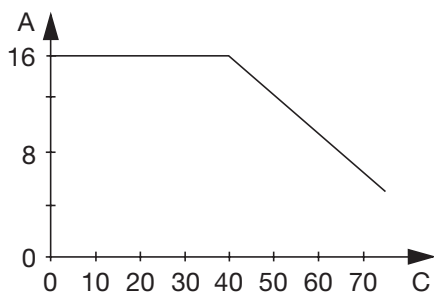

**1 change-over contact  
AC/DC/UC coil**

Ordering data	24VDC 1CO	48VDC 1CO	115VAC 1CO	230VAC 1CO
<b>Input</b>				
Rated voltage	24 V DC ±10%	48 V DC ±10 %	115 V AC +5 %/ -15 %	230 V AC + 5 / - 15%
Rated current AC			8 mA	4.5mA
Rated current DC	40 mA	20 mA		
Power rating	1W	1W	1 VA	1VA
AC Response/dropout Volt			98 V	195 V
DC Response/dropout Volt	21.5V	43 V		
AC pickup/dropout current			-1.5mA	-/2.2mA
DC pickup/dropout current	-/11.5mA	-/13.5mA		
<b>Ordering data Complete module</b>				
Screw connection Type	RS 31 24VDC LD LP 1U	RS 31 48VDC LD 1U LP	RS 31 115VAC LD LP 1U	RS 31 230VAC LD LP 1U
Order No.	<b>1128361001</b>	<b>1150761001</b>	<b>1150461001</b>	<b>1128461001</b>
Tension spring connection Type				
Order No.				
<b>Ordering data Spare relay (pluggable)</b>				
Type				
Order No.				
<b>Note</b>				
<b>Ordering data</b>				
<b>Input</b>				
Rated voltage				
Rated current AC				
Rated current DC				
Power rating				
AC Response/dropout Volt				
DC Response/dropout Volt				
AC pickup/dropout current				
DC pickup/dropout current				
<b>Ordering data Complete module</b>				
Screw connection Type				
Order No.				
Tension spring connection Type				
Order No.				
<b>Ordering data Spare relay (pluggable)</b>				
Type				
Order No.				
<b>Note</b>				

Relays - RS-SERIES - RS 32

2 change-over contacts  
DC coil

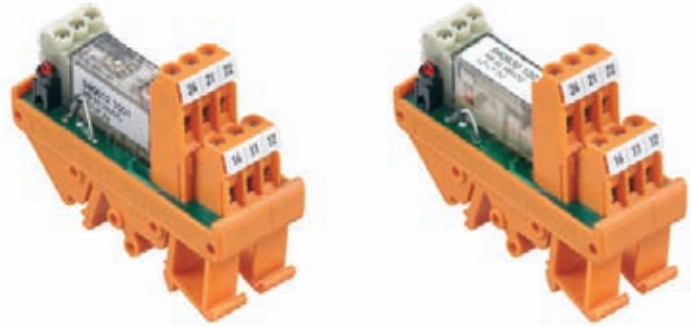

C

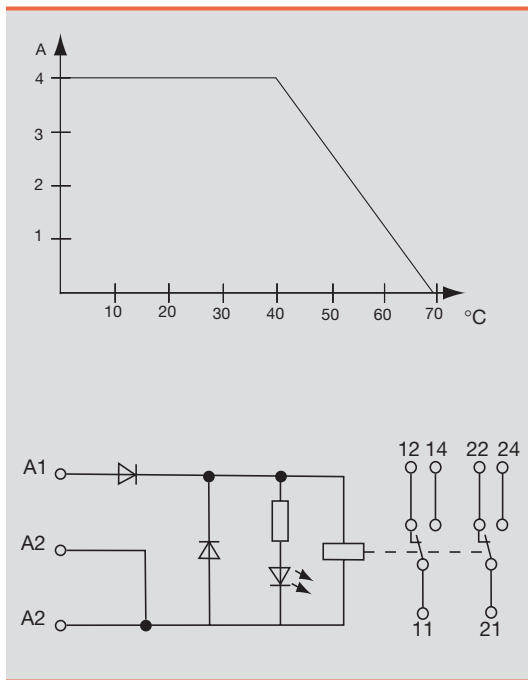

Output	
max. switching voltage AC1/Continuous current	250 V/4 A
min. switching power	10 V / 10 mA
Response time / Drop-out time	13ms/10ms
Contact base material	AgNi 90/10
Mechanical endurance	>30*10 <sup>6</sup> switching cycles
max. switching frequency at rated load	0.1 Hz
Rated data	
Status indicator/Free wheel diode	LED red/no
Reverse pol. prot	available
Operating temperature	-25 °C...+40 °C
Storage temperature	-40 °C...+60 °C
Humidity	40°C/93% RH, no condensation
Approvals	CE;
Insulation coordination (EN 50178)	
Standards	EN 50178
Rated voltage	250 V
Impulse withstand voltage	4 kV
Creepage and clearance path input - output	3 mm
Surge category	III
Pollution severity	2
Protective separation to VDE 0106 part 101	no
Dimensions	
Clamping range (rating- / min. / max.)	mm <sup>2</sup> 2.5 / 0.5 / 4
Length x width x height	mm 70 / 25 / 63.5
Note	

Ordering data	12VDC 2CO	24VDC 2CO	48VDC 2CO	
<b>Input</b>				
Rated voltage	12 V DC ±10 %	24 V DC ±10%	48 V DC ±10 %	
Rated current AC				
Rated current DC	50 mA	25 mA	12 mA	
Power rating	0.6W	0.6W	0.6W	
AC Response/dropout Volt				
DC Response/dropout Volt	11 V	21.5V	43 V	
AC pickup/dropout current				
DC pickup/dropout current	-/9.5mA	-/5 mA	-/2 mA	
<b>Ordering data Complete module</b>				
Screw connection Type	RS 32 12VDC LD LP 2U	RS 32 24VDC LD LP 2U	RS 32 48VDC LD LP 2U	
Order No.	9406021001	9406121001	9406321001	
Tension clamp connection Type				
Order No.				
<b>Ordering data Spare relay, pluggable</b>				
Type				
Order No.				
<b>Note</b>				

2 change over contacts  
UC coil

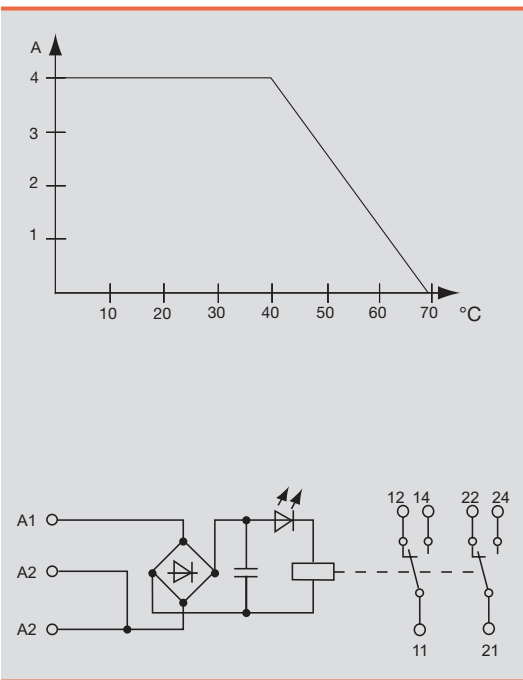
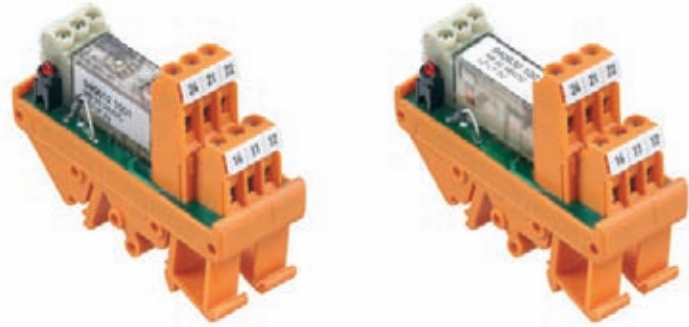

<b>Output</b>	
max. switching voltage AC1/Continuous current	250 V/4 A
min. switching power	5 V / 10 mA
Response time / Drop-out time	13ms/10ms
Contact base material	AgNi 90/10
Mechanical endurance	>30*10 <sup>6</sup> switching cycles
max. switching frequency at rated load	0.1 Hz
<b>Rated data</b>	
Status indicator/Free wheel diode	LED red/no
Reverse pol. prot	available
Operating temperature	-25 °C...+40 °C
Storage temperature	-40 °C...+60 °C
Humidity	40°C/93% RH, no condensation
Approvals	CE;
<b>Insulation coordination (EN 50178)</b>	
Standards	EN 50178
Rated voltage	250 V
Impulse withstand voltage	4 kV
Creepage and clearance path input - output	3 mm
Surge category	III
Pollution severity	2
Protective separation to VDE 0106 part 101	no
<b>Dimensions</b>	
Clamping range (rating- / min. / max.)	mm <sup>2</sup> 2.5 / 0.5 / 4
Length x width x height	mm 70 / 25 / 63.5
<b>Note</b>	

Ordering data	24VUC 2CO	48VUC 2CO	115VUC 2CO	230VUC 2CO
<b>Input</b>				
Rated voltage	24 V UC ±10 %	48 V UC ±10 %	115 V UC + 5 / - 15%	230 V UC + 5 / - 15%
Rated current AC	28 mA	18mAac	5mA	4.3mA
Rated current DC	18 mA	12 mA	5 mA	4.3mA
Power rating	0.6W // 0.9VA	0.6W // 0.9VA	0.5W // 0.6VA	1W //1VA
AC Response/dropout Volt				
DC Response/dropout Volt	21.5V	43 V	98 V	195 V
AC pickup/dropout current	-/2.5mA	-/4.5mA	-/1.5mA	-/2 mA
DC pickup/dropout current	-/4.5mA	-/2 mA	-/1 mA	-/1.2mA
<b>Ordering data Complete module</b>				
Screw connection Type	RS 32 24VUC LD LP 2U	RS 32 48VUC LD LP 2U	RS 32 115VUC LD LP 2U	RS 32 230VUC LD LP 2U
Order No.	9406221001	9406421001	9406621001	9406721001
Tension clamp connection Type				
Order No.				
<b>Ordering data Spare relay, pluggable</b>				
Type				
Order No.				
<b>Note</b>				

2 change over contacts  
multiple voltage input

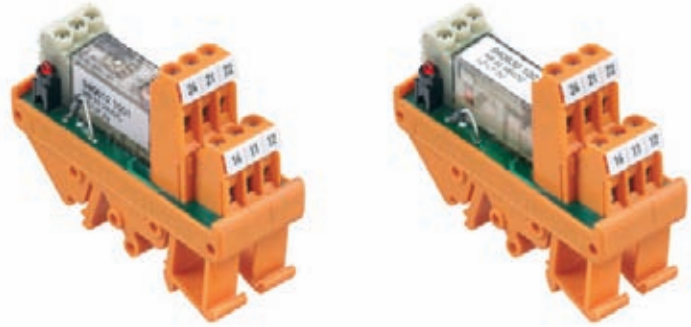

C

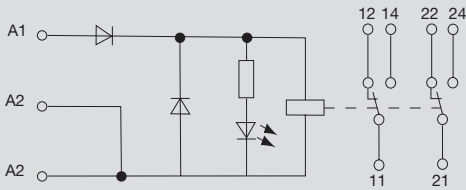
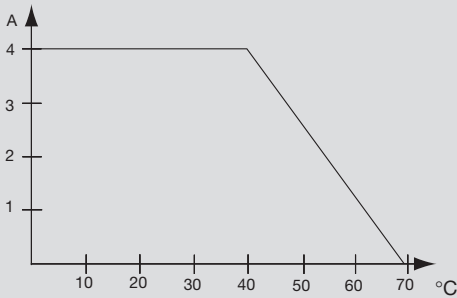

Output		
max. switching voltage AC1/Continuous current	250 V/4 A	
min. switching power	10 V / 10 mA	
Response time / Drop-out time	13ms/10ms	
Contact base material	AgNi 90/10	
Mechanical endurance	>30*10 <sup>6</sup> switching cycles	
max. switching frequency at rated load	0.1 Hz	
Rated data		
Status indicator/Free wheel diode	LED red/no	
Reverse pol. prot	available	
Operating temperature	-25 °C...+40 °C	
Storage temperature	-40 °C...+60 °C	
Humidity	40°C/93% RH, no condensation	
Approvals	CE;	
Insulation coordination (EN 50178)		
Standards	EN 50178	
Rated voltage	250 V	
Impulse withstand voltage	4 kV	
Creepage and clearance path input - output	3 mm	
Surge category	III	
Pollution severity	2	
Protective separation to VDE 0106 part 101	no	
Dimensions		
Clamping range (rating- / min. / max.)	mm <sup>2</sup>	2.5 / 0.5 / 4
Length x width x height	mm	70 / 25 / 63.5
Note		

Ordering data

Input	24-48VUC 2CO	115-230VUC 2CO		
Rated voltage	24 V // 48 V UC ±10 %	115 // 230 V UC + 5 / - 15%		
Rated current AC	28 mA / 22 mA	5.6mA/5.3mA		
Rated current DC	18 mA / 20 mA	5.4mA/5mA		
Power rating	0.6W // 0.9VA	1W // 1VA		
AC Response/dropout Volt				
DC Response/dropout Volt	21.5V/43V	98 V/ 195 V		
AC pickup/dropout current	-/3mA // -/4.5mA	-/1.5mA // -/2mA		
DC pickup/dropout current	-/5mA // -/2mA	-/1mA // -/1.2mA		

Ordering data

Complete module				
Screw connection	Type	RS 32 24-48VUC LD LP 2U	RS 32 115-230VUC LD 2U	
	Order No.	<b>1122661001</b>	<b>1122761001</b>	
Tension clamp connection	Type			
	Order No.			

Ordering data

Spare relay, pluggable				
	Type			
	Order No.			

Note				

**2 changeover contacts**  
**Positive-action contacts**

- DC coil
- Relay with 2 positive-action changeover contacts to EN 50205
- 2-pole safety relay with 2 changeover contacts \*)
- Mounts on TS32/35

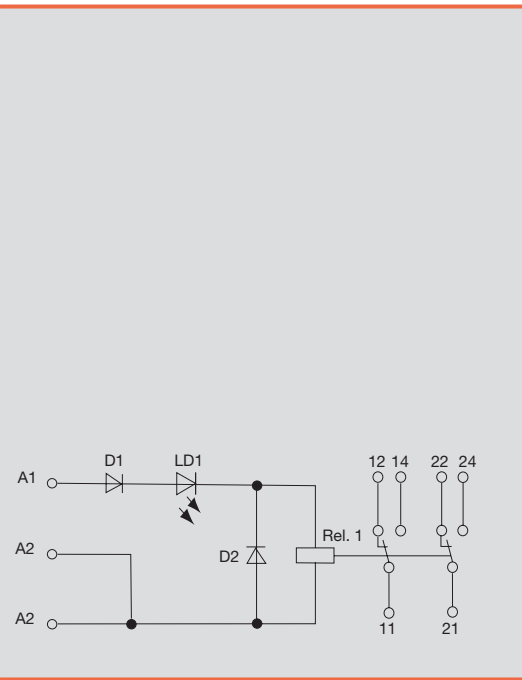

Output			
max. switching voltage AC1/Continuous current	250 V/4 A		
min. switching power	5 V / 10 mA		
Response time / Drop-out time	13ms/10ms		
Contact base material	AgNi 90/10		
Mechanical endurance	> 20 x 10 <sup>6</sup> switching operations		
max. switching frequency at rated load	0.1 Hz		
Rated data			
Status indicator/Free wheel diode	LED red/no		
Reverse pol. prot	Yes		
Operating temperature	-25 °C...+40 °C		
Storage temperature	-40 °C...+85 °C		
Humidity	40°C/93% RH, no condensation		
Approvals	CE;		
Insulation coordination (EN 50178)			
Standards	EN 50178		
Rated voltage	300 V		
Impulse withstand voltage	4 kV		
Creepage and clearance path input - output	4 mm		
Surge category	III		
Pollution severity	2		
Protective separation to VDE 0106 part 101	no		
Dimensions		Screw connection	Tension clamp connection
Clamping range (rating- / min. / max.)	mm <sup>2</sup>	2.5 / 0.5 / 4	
Length x width x height	mm	70 / 25 / 63.5	
Note		*) According to EN50205, only the use of 1 make contact/1 break contact is permitted for the safety circuit.	

**Ordering data**

Input		24 V DC 2CO			
Rated voltage		24 V DC ±10%			
Rated current AC					
Rated current DC		21 mA			
Power rating		0.5 W			
AC Response/dropout Volt					
DC Response/dropout Volt		16 V // 10 V			
AC pickup/dropout current					
DC pickup/dropout current		12.5 mA // 7 mA			
Ordering data Complete module					
Screw connection	Type	RS32 24 VDC SAFETY			
	Order No.	<b>8872160000</b>			
Tension clamp connection	Type				
	Order No.				
Ordering data Spare relay, pluggable					
	Type				
	Order No.				
Note					

## Relays - RS-SERIES - with RSM multiple interface

### 4-/8-/16-way, ea. with 1 COC

- Red LEDs , other colours on request
- Mounting feet can also be mounted turned through an angle of 180°

#### RSM 4 R / RSM 4 RS

4 relays  
soldered or plug-in

#### RSM 8 R / RSM 8 RS

8 relays  
soldered or plug-in

#### RSM 16 R / RSM 16 RS

16 relays  
soldered or plug-in

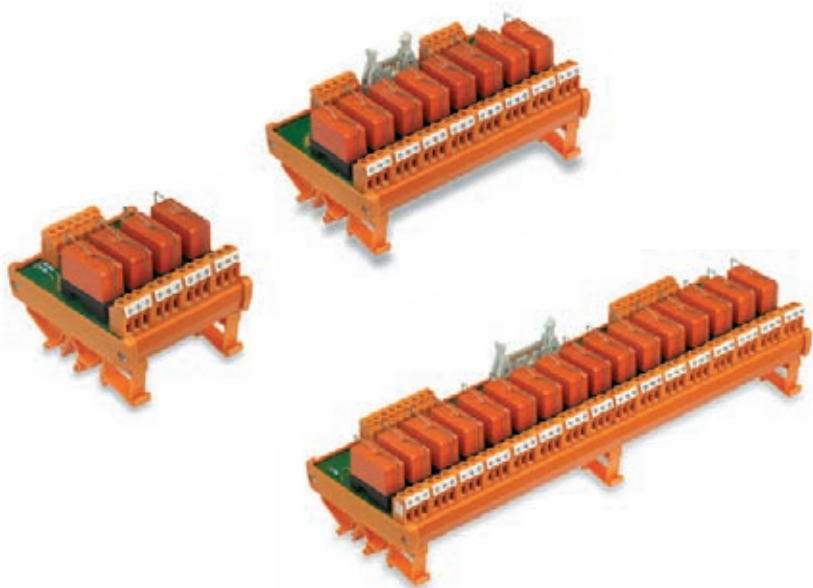

### Technical data

Rated data	
Input voltage	
Nominal consumption	soldered relay plug-in relay
Nominal consumption	soldered relay plug-in relay
Pick-up current	soldered relay plug-in relay
Pick-up current	soldered relay plug-in relay
Drop-out current of relay (at 20 °C)	
Output voltage max.	
Continuous current	
Derating curve	
a = fitted on mounting rail in horizontal row without spacing b = fitted on mounting rail in horizontal row with 20 mm spacing	
Continuous current	Ambient temperature
Typical making times	
	Pick-up delay ( AC / DC) Drop-out delay ( AC / DC)
Duration of bounce	
Making current	
Making power under ohmic load	
Min. switching power / switching current	
Contact material	
Service life	mechanical 24 V DC, 1A, ohmic load 230 V AC, 3A, ohmic load
Storage temperature	
Ambient temperature	
Insulation coordination to EN 50178	
Surge category	
Pollution severity	
Dimensions	
Conductor cross-section (screw connection)	

24 V DC	24 V AC/DC	48 V DC	115 V AC/DC	230 V AC
0.45 W	–	–	–	–
0.75 W	0.45 W	0.75 W	–	–
–	–	–	–	–
–	0.7 VA	–	0.6 VA	1.2 VA
12 mA	–	–	–	–
23 mA	12 mA	14 mA	5 mA	–
–	–	–	–	–
–	16.5 mA	–	6 mA	4 mA
2 mA	–	1.5 mA	–	1 mA
250 V	250 V	250 V	250 V	250 V
6 A	6 A	6 A	6 A	3 A

  

24 V...115 V		230 V	
≤ 8 ms	≤ 10 ms / 10 ms	≤ 12 ms	≤ 8 ms / 10 ms
≤ 7 ms	≤ 15 ms / 20 ms	≤ 11 ms	≤ 5 ms / 8 ms

≤ 3 ms
8 A
2000 VA
250 mW/10 mA
AgNi 90/10, AgNi0,15, gold-flashed
> 30 x 10 <sup>6</sup> switching cycles
> 5 x 10 <sup>5</sup> switching cycles
> 7 x 10 <sup>5</sup> switching cycles
–40 °C ... +60 °C
–25 °C ... +50 °C
III
2
0.5 ... 2.5 mm <sup>2</sup>

**DC/AC/AC voltage**

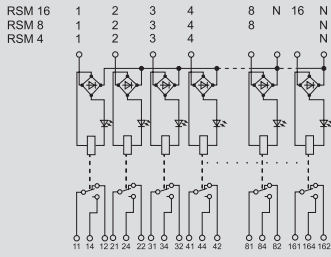

**DC voltage, negative-switching**

common plus potential,  
minus connected

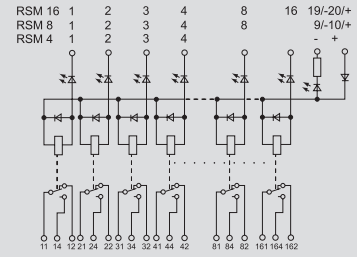

**DC voltage, positive-switching**

common minus potential,  
plus connected

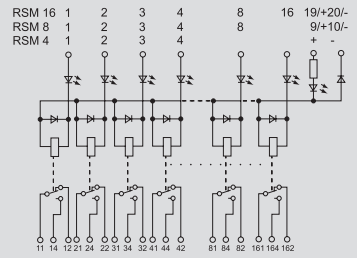

**Ordering data**

**Connection system**

- Input **Screw connection**
- Plug-in relay  
Screw connection and multiple plug to IEC 603-1/DIN 41651
  - Relay soldered  
Multiple plug to IEC 603-1/DIN 41651
- Output **Screw connection**

		4 relays RSM 4 R/RS (B = 75 mm)	8 relays RSM 8 R/RS (B = 145 mm)	16 relays RSM 16 R/RS (B = 285 mm)
<b>Input voltage</b>	<b>24 V DC, switching plus</b>	Relay pluggable 1113361001 <sup>1)</sup>	1113561001 <sup>1)</sup>	1113761001 <sup>1)</sup>
		Relay soldered 1112361001	1107761001	1107861001
	<b>24 V DC, switching minus</b>	1113461001 <sup>1)</sup>	1113661001 <sup>1)</sup>	1113861001 <sup>1)</sup>
	<b>24 V AC/DC</b>	1173461001	1173561001	1173661001
	<b>48 V DC, switching plus</b>		1114161001	
	<b>115 V AC/DC</b>	1114561001	1114661001	1114761001
	<b>230 V AC</b>	1114861001	1114961001	1115061001

<sup>1)</sup> approved by Germanisch Lloyd

**Spare relays (pluggable)**

For RSM ... R/RS, 24 V

For RSM ... R/RS, 48 V

For RSM ... R/RS, 115 V and 230 V

Input voltage	Contact material	Remarks	Order no.
<b>24 V DC</b>	AgNi 90/10	RT 314024 with clip	8630780000
	AgNi 90/10	RT 314024 without clip	4058480000
<b>48 V DC</b>	AgNi 90/10	RT 314048 without clip	4058740000
<b>115 V DC</b>	AgNi 90/10	RT 314110 with clip	8630770000
	AgNi 90/10	RT 314110 without clip	4058500000

Relays - WAVESERIES

1 change-over contact  
AC/DC/UC coil



C

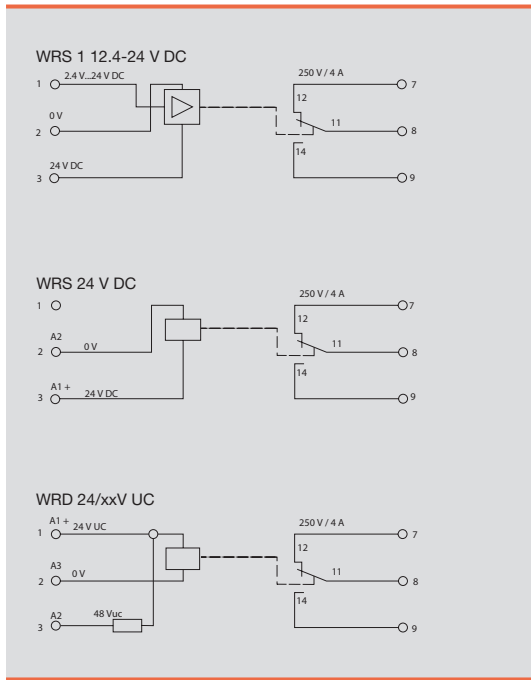

Output		
max. switching voltage AC1/Continuous current	250 V/5 A	
min. switching power	100 mA / 5 V DC	
Response time / Drop-out time	7ms/6ms	
Contact base material	Gold alloy	
Mechanical endurance	20*10 <sup>6</sup> switching cycles	
max. switching frequency at rated load	0.1 Hz	
Rated data		
Status indicator/Free wheel diode	green LED/Yes	
Reverse pol. prot	available	
Operating temperature	-25 °C...+50 °C	
Storage temperature	-40 °C...+60 °C	
Humidity	40°C/93% RH, no condensation	
Approvals	CSA;cURus;CE;	
Insulation coordination (EN 50178)		
Standards	EN 50178	
Rated voltage	300 V	
Impulse withstand voltage	6 kV (1.2/50 µs)	
Creepage and clearance path input - output	≥ 5.5 mm	
Surge category	III	
Pollution severity	2	
Protective separation to VDE 0106 part 101	yes	
Dimensions	Screw connection	Tension clamp connection
Clamping range (rating- / min. / max.)	mm <sup>2</sup>	1.5 / 0.5 / 2.5
Length x width x height	mm	72 / 22.5 / 92.4
Note		

Applications

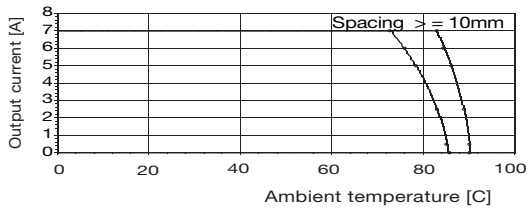

1 change-over contact  
AC/DC/UC coil

Ordering data	2.4-24 V DC 1CO	24 V DC 1CO	24 / 48 V UC 1CO	24 V UC/230 V AC 1CO
<b>Input</b>				
Rated voltage	2,4...24 V DC ±10 %	24 V DC ±10%	24 V // 48 V UC ±10 %	24 V UC // 230 V AC, ±10 %
Rated current AC			approx. 14 mA	approx. 15 mA
Rated current DC	4.6 mA	9 mA	14 mA	14 mA (24 V DC)
Power rating	200 mW	220 mW	0.35 VA / 0.5 VA	0,34 VA / 0,32 W // 3,5 VA
AC Response/dropout Volt			16 V/9,5 V // 29 V/15 V	13 V /9 V //115 V /66 V
DC Response/dropout Volt	1.9 V	16 V / 7.5 V	16 V/9,5 V // 29 V/15 V	13 V /9 V (24 V DC)
AC pickup/dropout current			9 mA/4,5 mA // 8,3 mA/4,1 mA	7.5 mA/4.7 mA // 7.4 mA/4.3 mA
DC pickup/dropout current	3.88 mA	5.7 mA / 2.2 mA	9 mA/4,5 mA // 8,3 mA/4,1 mA	7.5 mA/4.7 mA
<b>Ordering data Complete module</b>				
Screw connection Type	WRS1 2.4-24VDC 1U	WRS1 24VDC 1U	WRS1 24/48VUC 1U	WRS1 24VUC/230VAC 1U
Order No.	8275320000	8275350000	8286280000	8418230000
Tension spring connection Type				
Order No.				
<b>Ordering data Spare relay (pluggable)</b>				
Type				
Order No.				
<b>Note</b>				
<b>Ordering data</b>				
<b>Input</b>				
Rated voltage				
Rated current AC				
Rated current DC				
Power rating				
AC Response/dropout Volt				
DC Response/dropout Volt				
AC pickup/dropout current				
DC pickup/dropout current				
<b>Ordering data Complete module</b>				
Screw connection Type				
Order No.				
Tension spring connection Type				
Order No.				
<b>Ordering data Spare relay (pluggable)</b>				
Type				
Order No.				
<b>Note</b>				

Relays - WAVESERIES

2 NO contacts  
AC/DC/UC coil



C

Derating curve

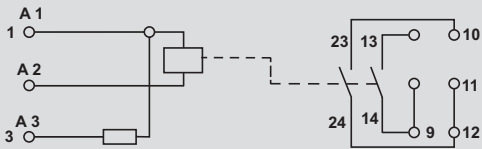
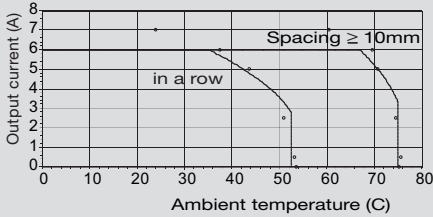

Output		
max. switching voltage AC1/Continuous current	250 V/5 A	
min. switching power	100 mA / 5 V DC	
Response time / Drop-out time	5ms/6ms	
Contact base material	AgSnO2	
Mechanical endurance	50*10 <sup>6</sup> switching cycles	
max. switching frequency at rated load	0.1 Hz	
Rated data		
Status indicator/Free wheel diode	green LED/Yes	
Reverse pol. prot	available	
Operating temperature	-25 °C...+50 °C	
Storage temperature	-40 °C...+60 °C	
Humidity	40°C/93% RH, no condensation	
Approvals	CSA;cURus;CE;	
Insulation coordination (EN 50178)		
Standards	EN 50178	
Rated voltage	300 V	
Impulse withstand voltage	6 kV (1.2/50 µs)	
Creepage and clearance path input - output	≥ 8 mm	
Surge category	III	
Pollution severity	2	
Protective separation to VDE 0106 part 101	yes	
Dimensions	Screw connection	Tension clamp connection
Clamping range (rating- / min. / max.)	mm <sup>2</sup>	1.5 / 0.5 / 2.5
Length x width x height	mm	92.4 / 22.5 / 112.4
Note		

Ordering data

Input	12 / 24 V DC 2NO	24 / 48 V UC 2NO	115 V UC/230 V AC 2NO	
Rated voltage	12 V DC // 24 V DC, ±10 %	24 V // 48 V UC ±10 %	115 V UC // 230 V AC, ±10 %	
Rated current AC		approx. 11 mA	approx. 10 mA	
Rated current DC	approx. 20 mA	approx. 8.5 mA	9 mA (115 V DC)	
Power rating	0,24 W // 0,5 W	0,17 W/0,21 VA // 0,4 W/0,48 VA	1 VA / 0,9 W // 2,5 VA	
AC Response/dropout Volt		13,5 V /9 V // 24 V/16 V	58 V /22 V // 110 V/40 V	
DC Response/dropout Volt	7.5 V /3.5 V // 14.5 V/6.1 V	16 V /7.8 V // 28 V/12 V	54 V /20 V (115 V DC)	
AC pickup/dropout current		4,4 mA/2.7 mA // 4,3 mA/2.6 mA	4,8 mA/1.7 mA V // 5 mA/2 mA	
DC pickup/dropout current	10 mA/4.2 mA // 10 mA/4 mA	4,3 mA/1.6 mA // 4,4 mA/1.6 mA	4 mA / 2 mA	

Ordering data Complete module				
Screw connection	Type	WRS2 12/24VDC 2A	WRS2 24/48VUC 2A	WRS2 115VUC/230VAC 2A
	Order No.	8418240000	8418250000	8418260000
Tension clamp connection	Type			
	Order No.			

Ordering data Spare relay, pluggable				
	Type			
	Order No.			

Note				

1 NC contact / 1 NO contact  
DC/UC coil



Derating curve

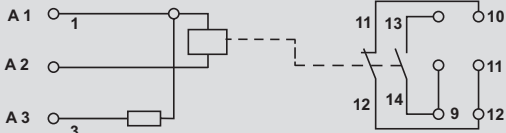
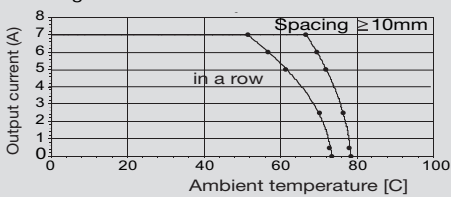

Output	
max. switching voltage AC/Continuous current	250 V/5 A
min. switching power	100 mA / 5 V
Response time / Drop-out time	7ms/5ms
Contact base material	AgSnO2
Mechanical endurance	50*10 <sup>6</sup> switching cycles
max. switching frequency at rated load	0.1 Hz
Rated data	
Status indicator/Free wheel diode	green LED/Yes
Reverse pol. prot	available
Operating temperature	-25 °C...+50 °C
Storage temperature	-40 °C...+60 °C
Humidity	40°C/93% RH, no condensation
Approvals	CSA;cURus;CE;
Insulation coordination (EN 50178)	
Standards	EN 50178
Rated voltage	300 V
Impulse withstand voltage	6 kV (1.2/50 µs)
Creepage and clearance path input - output	≥ 8 mm
Surge category	III
Pollution severity	2
Protective separation to VDE 0106 part 101	yes

Dimensions	Screw connection	Tension clamp connection
Clamping range (rating- / min. / max.)	mm <sup>2</sup> 1.5 / 0.5 / 2.5	
Length x width x height	mm 92.4 / 22.5 / 112.4	

Note

Ordering data

Input	12/24 V DC 1NO/1NC	24/48 V UC 1NO/1NC	115 V UC/230 V AC	
Rated voltage	12 V DC // 24 V DC, ±10 %	24 V // 48 V UC ±10 %	115 V UC // 230 V AC, ±10 %	
Rated current AC		approx. 11 mA	approx. 10 mA	
Rated current DC	approx. 20 mA	approx. 8.5 mA	9 mA (115 V DC)	
Power rating	0,24 W // 0,5 W	0,17 W/0,21 VA // 0,4 W/0,48 VA	1 VA / 0,9 W // 2,5 VA	
AC Response/dropout Volt		13.5 V /9 V // 24 V/16 V	58 V /22 V // 110 V/40 V	
DC Response/dropout Volt	7.5 V /3.5 V // 14.5 V/6.1 V	13.5 V /9 V // 24 V/16 V	54 V /20 V (115 V DC)	
AC pickup/dropout current		4.4 mA/2.7 mA // 4.3 mA/1.6 mA	4.8 mA/1.7 mA // 5 mA/2 mA	
DC pickup/dropout current	10 mA/4.2 mA // 10 mA/4 mA	4.3 mA/1.6 mA // 4.4 mA/1.6 mA	4 mA/1.6 mA	

Ordering data Complete module				
Screw connection Type	WRS2 12/24VDC 1A1R	WRS2 24/48VUC 1A1R	WRS2 115VUC/230VAC 1A1R	
Order No.	8418270000	8418280000	8418290000	
Tension clamp connection Type				
Order No.				

Ordering data Spare relay, pluggable				
Type				
Order No.				

Note

## Relays - WAVESERIES

### 2 change-over contacts AC/DC/UC coil



C

Derating curve

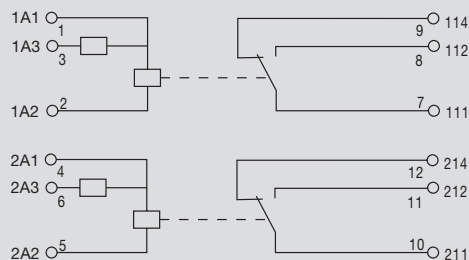
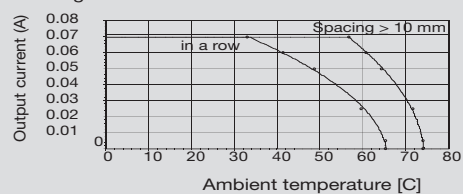

Output	
max. switching voltage AC1/Continuous current	250 V/5 A
min. switching power	100 mA / 5 V DC
Response time / Drop-out time	6ms/10ms
Contact base material	Gold alloy
Mechanical endurance	20*10 <sup>6</sup> switching cycles
max. switching frequency at rated load	0.1 Hz
Rated data	
Status indicator/Free wheel diode	green LED/Yes
Reverse pol. prot	available
Operating temperature	-25 °C...+50 °C
Storage temperature	-40 °C...+60 °C
Humidity	40°C/93% RH, no condensation
Approvals	CSA;cURus;CE;
Insulation coordination (EN 50178)	
Standards	EN 50178
Rated voltage	300 V
Impulse withstand voltage	6 kV (1.2/50 µs)
Creepage and clearance path input - output	≥ 5.5 mm
Surge category	III
Pollution severity	2
Protective separation to VDE 0106 part 101	yes
Dimensions	
Clamping range (rating- / min. / max.)	mm <sup>2</sup> 1.5 / 0.5 / 2.5
Length x width x height	mm 92.4 / 22.5 / 112.4
Note	

#### Ordering data

Input	12/24 V DC 2CO	24/48 V UC 2CO	24 V UC/230 V AC 2CO	
Rated voltage	12 V DC // 24 V DC, ±10 %	24 V // 48 V UC ±10 %	24 V UC // 230 V AC, ±10 %	
Rated current AC		approx. 15 mA	approx. 15 mA	
Rated current DC	approx. 23 mA	14 mA	14 mA (24 V DC)	
Power rating	0,26 W // 0,53 W	0,35 VA(W) // 0,7 VA(W)	0,35 W // 3,45 VA	
AC Response/dropout Volt			13 V/9 V // 115 V/66 V	
DC Response/dropout Volt	8,5 V /3 V // 15 V/4,8 V	16 V /9,5 V // 29 V /15 V	13 V / 9 V (24 V DC)	
AC pickup/dropout current		9 mA/4,5 mA // 8,3 mA/4,1 mA	7,5 mA/4,7 mA // 7,4 mA/4,3 mA	
DC pickup/dropout current	15,2 mA/5,7 mA//15,3 mA/5,6 mA	9 mA/4,5 mA // 8,3 mA/4,1 mA	7,5 mA // 4,7 mA	

#### Ordering data

Complete module				
Screw connection	Type	WRS2 12/24VDC 2U	WRS2 24/48VUC 2U	WRS2 24VUC/230VAC 2U
	Order No.	841830000	841831000	841832000
Tension clamp connection	Type			
	Order No.			

#### Ordering data

Spare relay, pluggable				
	Type			
	Order No.			

Note				



# Housing forms for optos

## DK-SERIES



All components of the DKO mini-coupler are extremely slim: the use of the latest surface-mounted devices (SMD) allows us to keep the width to just 6 mm. The mini-couplers support a wide range of applications relating to the coupling of digital sensor/actuator signals with automation devices and the process field. DKO optos are designed to pick up and standardise signals of different voltages from the field.

## MICROSERIES



The **MICROSERIES** range integrates the product features of the RSS power relay into the world of terminals. The user therefore benefits from the special features of terminals: he retains a free choice of connection system, plug-in cross-connection, standardised marking solutions as well as the space saving advantage typical of relays!

## WAVESERIES



Innovative electronic components require a housing or enclosure that reflects their specific functions. They must allow adjustment and operation functions and support electro-mechanical requirements such as heat dissipation or electromagnetic compatibility. A compact design saves space in the control cabinet and reduces assembly costs. Ergonomic design is increasingly important for top-quality opto interfaces.

## MCZ-SERIES



The MCZ enclosure is only 6 mm wide and one of the narrowest of its kind. Its outstanding technical features include:

- Tension clamp connection to reduce assembly costs
- Integrated cross-connection in input and output minimizes wiring workload.

## PLUGSERIES



The **PLUGSERIES** offers you proven product features from the world of connection systems combined with the performance of the Weidmüller RCL power relay. The plug-in cross-connection ZQV enables quick and easy bridging of input and output potentials. Besides a free choice of the connection system, PLUGSERIES products are unique as a result of the Wemid housing material.

## JACKPAC®



JACKPAC® integrates basic functions of signal processing such as amplification, isolation and conversion of signals, but also provides protective functions thanks to packaging to IP68 standard that is compatible with field wiring conditions. This allows you to both realise decentralised wiring concepts without having to accept a compromise solution and to optimally use digital input-output components from the IP6X world.



# The control side of the opto interface

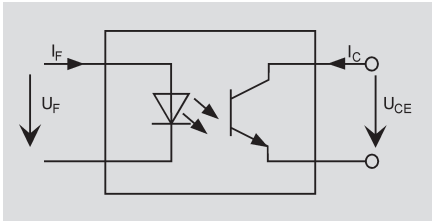

## Optos for electrical or “protective separation”

The partial discharge test to DIN VDE 0884 is the primary requirement for “protective separation” with optoelectronic coupling components. Doubled or reinforced insulation for “protective separation” must protect against partial discharge. A high-voltage test, as is customary for relays, cannot be carried out with semiconductors because the voltage can cause irreparable damage. “Protective separation” for coupling components with integral optos is deemed to be provided for the given rated voltage when the following requirements are fulfilled:

- optos passes test to DIN VDE 0884,
- creepage distances and clearances on PCBs and connection components comply with EN 50178, DIN VDE 0106 or 0109.

We distinguish between three principal circuit arrangements on the input side of the opto interface:

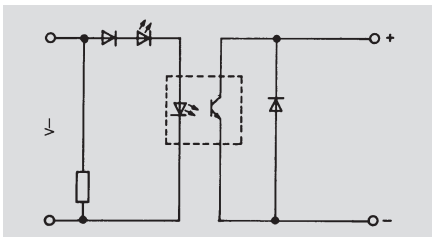

### – DC input

with diode to protect against reverse polarity (reversing the input polarity could cause irreparable damage to the component).

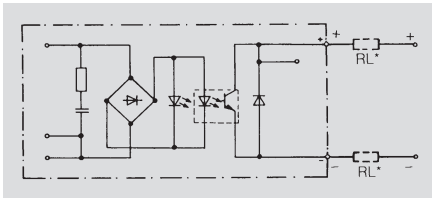

### – AC/DC input

In this input circuit it is not possible to reverse the polarity of the DC input signal. The disadvantage of the AC/DC input circuit (with control by DC signal) is the lower operating frequency of the component because the charging capacitor (CL, required for AC input signals) lowers the maximum operating frequency.

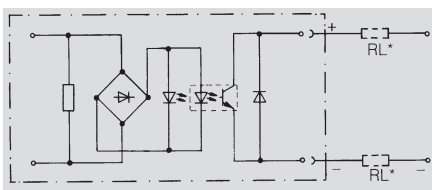

### – AC input

Here again, the charging capacitor has a considerable influence on the maximum operating frequency of the complete component. Weidmüller optos with AC/DC or AC input signals are designed for mains frequencies of approx. 40 ... 60 Hz. In the case of AC input signals the maximum operating frequency of the optos component is less than half the mains frequency. A higher operating frequency is not feasible because otherwise the outcome would be constant switching in the rhythm of the mains frequency.

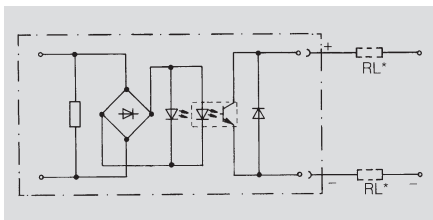

**2-pole DC output**

The 2-pole DC output is comparable with a conventional switch. In this variation the location of the load (in the output circuit) is irrelevant. However, the output supply voltage required must be available with the right polarity.

Opto components are generally specified with an output supply voltage range of, for example, 5 ... 48 V DC. On no account should the voltage lie outside this range. The load current should not be higher than the specified maximum output current. A constant higher voltage will cause irreparable damage to the output stage. Derating curves show how the output current is dependent on the ambient temperature (given on the following pages for the various products).

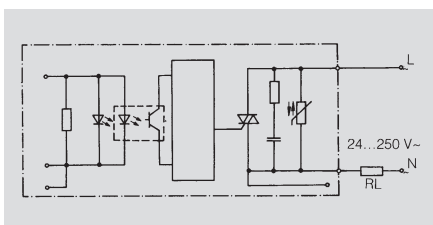

**2-pole AC output**

A special semiconductor element (TRIAC) is incorporated in the output stage of the optos for switching AC voltages. Like with the DC output, the characteristic parameters such as voltage, frequency, maximum load current and ambient temperature must be taken into account. The use of the zero-voltage switch ensures that the load is connected only when the voltage is zero. To protect against unacceptable voltage peaks, the components are always fitted with appropriate protective elements (varistor, RC combination).

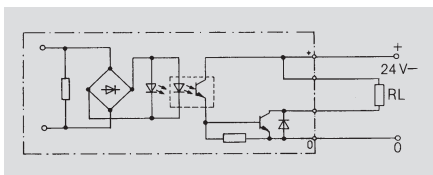

**3-pole DC output**

To guarantee reliable operation, this form of the output stage requires a non-floating output supply voltage with one output. It is designed either for positive-switching (common reference potential: GND or 0 V) or for negative-switching (common reference potential: positive voltage terminal).

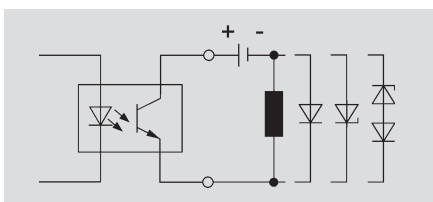

**Protective circuit**

All opto components are provided with a protective circuit (normally a free-wheel diode) at the output. To prevent interference from other signals in other lines, the load side must be protected.

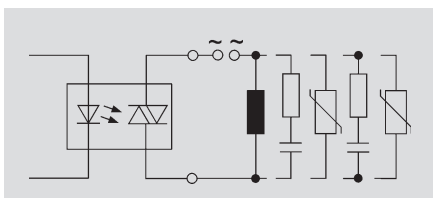

## Optos - DK-SERIES

### Mini-coupler DKO

- Coupling of digital sensor/actuator signals between PLC and process
- Inexpensive solution for adapting level and potential
- Low input power
- Screw connection system
- 6 mm width
- For mounting on TS 35

### 5 V DC



### 5 V TTL

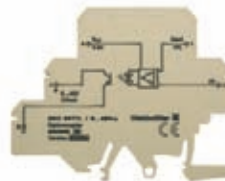

### 12 V DC 10 kHz

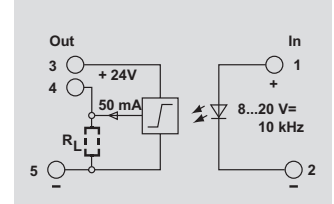
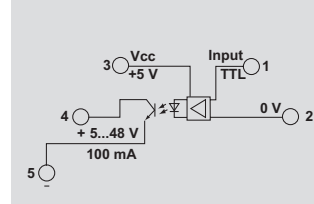
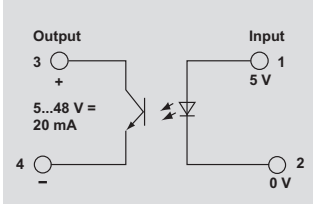

### Technical data

#### Input

Rated voltage  
Rated current  
Power rating  
max. input frequency  
Auxiliary voltage  
Status indicator

5 V DC ±5%  
10 mA  
50 mW  
300 Hz  
no  
LED green

5 V TTL  
1 µA  
50 µW  
3 kHz  
5 V  
LED green

8...20 V DC  
11 mA  
max. 130 mW  
max. 10 kHz  
no  
LED green

#### Output

Output voltage  
Output current (max.)  
Voltage drop at max. load  
Block-state curr. (closed-circuit curr.)  
Switch-on delay/Switch-off delay  
Short-circuit-proof/Protective circuit

5...48 V DC  
20 mA  
≤ 1,6 V  
50 µA  
≤ 15 µs/≤ 70 µs  
no/diode

5...48 V DC  
100 mA  
≤ 1,6 V  
≤ 50 µA  
approx. 27 µs/approx. 35 µs  
no/diode

24 V DC ±10%  
50 mA  
≤ 1 V  
≤ 50 µA  
1 µs/2,5 µs  
no/diode

#### General data

Operating temperature  
Storage temperature  
Approvals

-25 °C...+40 °C  
-40 °C...+85 °C  
CE;

-25 °C...+40 °C  
-40 °C...+85 °C  
CE;

-25 °C...+40 °C  
-40 °C...+85 °C  
CE;

#### Insulation coordination (EN 50 178)

Standards  
Rated voltage  
Rated impulse withstand voltage  
Creepage and clearance path input - output  
Surge category  
Pollution severity

EN 50178  
150 V  
4.0 kV  
≥ 4 mm  
III  
2

EN 50178  
300 V  
6.0 kV  
≥ 5.5 mm  
III  
2

EN 50178  
300 V  
6.0 kV  
≥ 5.5 mm  
III  
2

#### Dimensions

Clamping range (rating- / min. / max.) mm²  
Length x width x height mm

#### Screw connection

4 / 0,5 / 4  
65 x 6 x 57

#### Screw connection

4 / 0,5 / 4  
77 x 6 x 62

#### Screw connection

4 / 0,5 / 4  
65 x 12 x 57

#### Note

### Ordering data

#### Connection system

Screw connection

Type	(Qty.=1)	Order No.
DKO 35 5VDC		8018630000

Type	(Qty.=1)	Order No.
DKO 5 5VTTL		8228650000

Type	(Qty.=1)	Order No.
DKO 35 12VDC 10KHZ		8184030000

#### Note

Input at bottom

Input at bottom

Input at bottom

### Accessories

#### Note

End plate  
AP DKT4 0687560000

End plate  
AP DK 5 PA BE: 4036780000

End plate  
AP DKT 4: 0687560000

**Mini-coupler DKO**

- Coupling of digital sensor/actuator signals between PLC and process
- Inexpensive solution for adapting level and potential
- Low input power
- Screw connection system
- 6 mm width
- For mounting on TS 35

**24 V UC**

**24 V DC 3 kHz**

**24 V DC 3 kHz**

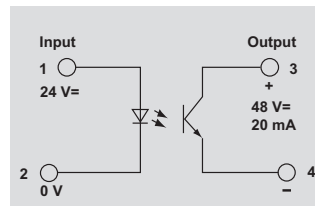
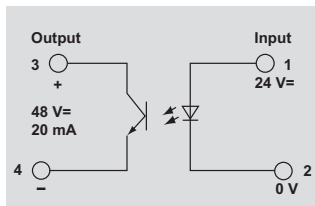
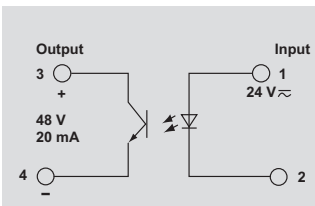

**Technical data**

<b>Input</b>	
Rated voltage	24 V UC ±10 %
Rated current	11,4 mA AC / 9,6 mA DC
Power rating	280 mVA / 230 mW
max. input frequency	10 Hz at DC
Auxiliary voltage	no
Status indicator	LED green
<b>Output</b>	
Output voltage	5...48 V DC
Output current (max.)	20 mA
Voltage drop at max. load	≤ 1 V
Block-state curr. (closed-circuit curr.)	≤ 50 µA
Switch-on delay/Switch-off delay	≤ 15 ms bei DC/≤ 25 ms bei DC
Short-circuit-proof/Protective circuit	no/diode
<b>General data</b>	
Operating temperature	-25 °C...+40 °C
Storage temperature	-40 °C...+85 °C
Approvals	CE;
<b>Insulation coordination (EN 50 178)</b>	
Standards	EN 50178
Rated voltage	300 V
Rated impulse withstand voltage	4.0 kV
Creepage and clearance path input - output	≥ 4 mm
Surge category	III
Pollution severity	2

<b>Input</b>	
Rated voltage	24 V DC ±10%
Rated current	≤ 15 mA
Power rating	max. 360 mW
max. input frequency	3 kHz
Auxiliary voltage	no
Status indicator	LED green
<b>Output</b>	
Output voltage	5...48 V DC
Output current (max.)	20 mA
Voltage drop at max. load	≤ 900 mV
Block-state curr. (closed-circuit curr.)	0.16 mA
Switch-on delay/Switch-off delay	approx. 50 µs/approx. 80 µs
Short-circuit-proof/Protective circuit	no/diode
<b>General data</b>	
Operating temperature	-25 °C...+40 °C
Storage temperature	-40 °C...+85 °C
Approvals	CE;
<b>Insulation coordination (EN 50 178)</b>	
Standards	EN 50178
Rated voltage	300 V
Rated impulse withstand voltage	4.0 kV
Creepage and clearance path input - output	≥ 4 mm
Surge category	III
Pollution severity	2

<b>Input</b>	
Rated voltage	24 V DC ±10%
Rated current	≤ 15 mA
Power rating	max. 360 mW
max. input frequency	3 kHz
Auxiliary voltage	no
Status indicator	LED green
<b>Output</b>	
Output voltage	5...48 V DC
Output current (max.)	20 mA
Voltage drop at max. load	≤ 900 mV
Block-state curr. (closed-circuit curr.)	50 µA
Switch-on delay/Switch-off delay	approx. 50 µs/approx. 80 µs
Short-circuit-proof/Protective circuit	no/diode
<b>General data</b>	
Operating temperature	-25 °C...+40 °C
Storage temperature	-40 °C...+85 °C
Approvals	CE;
<b>Insulation coordination (EN 50 178)</b>	
Standards	EN 50178
Rated voltage	300 V
Rated impulse withstand voltage	4.0 kV
Creepage and clearance path input - output	≥ 4 mm
Surge category	III
Pollution severity	2

<b>Dimensions</b>	
Clamping range (rating- / min. / max.)	mm²
Length x width x height	mm
<b>Note</b>	

<b>Screw connection</b>	
Clamping range (rating- / min. / max.)	4 / 0.5 / 4
Length x width x height	65 x 6 x 57
<b>Note</b>	

<b>Screw connection</b>	
Clamping range (rating- / min. / max.)	4 / 0.5 / 4
Length x width x height	65 x 6 x 57
<b>Note</b>	

<b>Screw connection</b>	
Clamping range (rating- / min. / max.)	4 / 0.5 / 4
Length x width x height	65 x 6 x 57
<b>Note</b>	

**Ordering data**

<b>Connection system</b>	
	Screw connection
<b>Note</b>	

<b>Type</b>	<b>(Qty.=1)</b>	<b>Order No.</b>
DKO 35 24VUC		8008150000
<b>Note</b>		
Input at bottom		

<b>Type</b>	<b>(Qty.=1)</b>	<b>Order No.</b>
DKO 35 24VDC 3KHZ E:U		8028300000
<b>Note</b>		
Input at bottom		

<b>Type</b>	<b>(Qty.=1)</b>	<b>Order No.</b>
DKO 35 24VDC 3KHZ E:O		8215640000
<b>Note</b>		
Input at top		

**Accessories**

<b>Note</b>	
-------------	--

<b>End plate</b>	AP DKT4 0687560000
------------------	--------------------

<b>End plate</b>	AP DKT4 0687560000
------------------	--------------------

<b>End plate</b>	AP DKT4 0687560000
------------------	--------------------

## Optos - DK-SERIES

### Mini-coupler DKO

- Coupling of digital sensor/actuator signals between PLC and process
- Inexpensive solution for adapting level and potential
- Low input power
- Screw connection system
- 6 mm width
- For mounting on TS 35

### 24 V DC 3 kHz

### 24 V DC 100 Hz

### 24 V DC 200 Hz

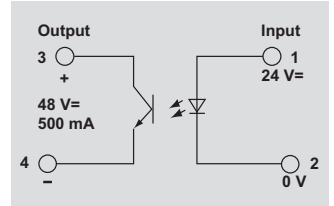
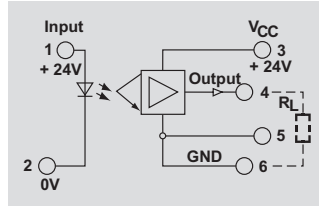
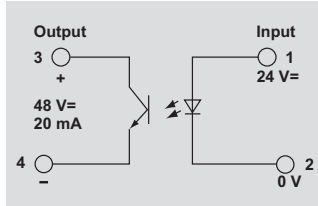

### Technical data

#### Input

Rated voltage  
Rated current  
Power rating  
max. input frequency  
Auxiliary voltage  
Status indicator

24 V DC  $\pm 10\%$   
8.5 mA  
max. 204 mW  
3 kHz  
no  
LED green

24 V DC  $\pm 10\%$   
12 mA  
max. 290 mW  
100 Hz  
no  
LED green

24 V DC  $\pm 10\%$   
6 mA  
145 mW  
200 Hz  
no  
LED green

#### Output

Output voltage  
Output current (max.)  
Voltage drop at max. load  
Block-state curr. (closed-circuit curr.)  
Switch-on delay/Switch-off delay  
Short-circuit-proof/Protective circuit

5...48 V DC  
20 mA  
 $\leq 900$  mV  
50  $\mu$ A  
approx. 50  $\mu$ s/approx. 80  $\mu$ s  
no/diode

24 V DC  $\pm 10\%$   
2 A  
  
2 ms/7 ms  
yes/varistor

5...48 V DC  
500 mA  
 $\leq 800$  mV  
  
approx. 40  $\mu$ s/approx. 65  $\mu$ s  
no/diode

#### General data

Operating temperature  
Storage temperature  
Approvals

-25 °C...+40 °C  
-40 °C...+85 °C  
CE;

-25 °C...+40 °C  
-40 °C...+85 °C  
CE;

-25 °C...+40 °C  
-40 °C...+85 °C  
CE;

#### Insulation coordination (EN 50 178)

Standards  
Rated voltage  
Rated impulse withstand voltage  
Creepage and clearance path input - output  
Surge category  
Pollution severity

EN 50178  
300 V  
4.0 kV  
 $\geq 4$  mm  
III  
2

EN 50178  
300 V  
4.0 kV  
 $\geq 3$  mm  
III  
2

EN 50178  
300 V  
4.0 kV  
 $\geq 4$  mm  
III  
2

#### Dimensions

Clamping range (rating- / min. / max.) mm<sup>2</sup>  
Length x width x height mm

#### Screw connection

4 / 0.5 / 4  
65 x 6 x 57

#### Screw connection

4 / 0.5 / 4  
65 x 12 x 57

#### Screw connection

4 / 0.5 / 4  
65 x 6 x 57

#### Note

### Ordering data

#### Connection system

Screw connection

Type	(Qty.=1)	Order No.
DKO 35 24VDC 3KHZ E:U		8248790000

Type	(Qty.=1)	Order No.
DKO 35 24VDC E:U		8181990000

Type	(Qty.=1)	Order No.
DKO 35 24VDC E:U		8019590000

#### Note

Input at bottom

Input at bottom

Input at bottom

### Accessories

#### Note

End plate  
AP DKT4 0687560000

End plate  
AP DKT4 0687560000

End plate  
AP DKT4 0687560000

**Mini-coupler DKO**

- Coupling of digital sensor/actuator signals between PLC and process
- Inexpensive solution for adapting level and potential
- Low input power
- Screw connection system
- 6 mm width
- For mounting on TS 35

**24 V DC 200 Hz**



**24 V DC 50 kHz**

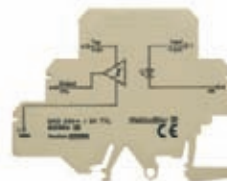

**24 V UC**

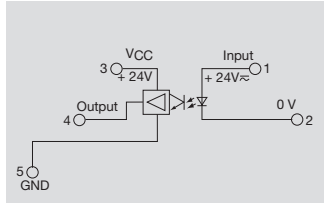
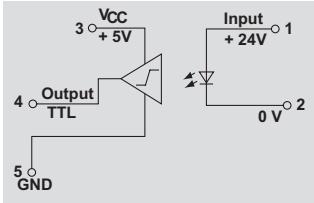
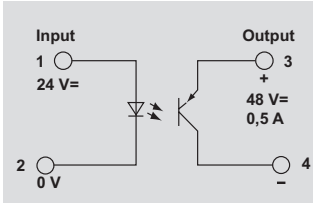
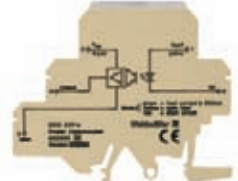

**Technical data**

Input	
Rated voltage	24 V DC ±10%
Rated current	6 mA
Power rating	max. 145 mW
max. input frequency	200 Hz
Auxiliary voltage	no
Status indicator	LED green
Output	
Output voltage	5...48 Vdc
Output current (max.)	500 mA
Voltage drop at max. load	≤ 800 mV
Block-state curr. (closed-circuit curr.)	≤ 10 µA
Switch-on delay/Switch-off delay	approx. 40 µs/approx. 65 µs
Short-circuit-proof/Protective circuit	no/diode
General data	
Operating temperature	-25 °C...+40 °C
Storage temperature	-40 °C...+85 °C
Approvals	CE;
Insulation coordination (EN 50 178)	
Standards	EN 50178
Rated voltage	300 V
Rated impulse withstand voltage	4.0 kV
Creepage and clearance path input - output	≥ 4 mm
Surge category	III
Pollution severity	2

Rated voltage	24 V DC ±10%
Rated current	6 mA
Power rating	max. 145 mW
max. input frequency	200 Hz
Auxiliary voltage	no
Status indicator	LED green
Output voltage	5...48 Vdc
Output current (max.)	500 mA
Voltage drop at max. load	≤ 800 mV
Block-state curr. (closed-circuit curr.)	≤ 10 µA
Switch-on delay/Switch-off delay	approx. 40 µs/approx. 65 µs
Short-circuit-proof/Protective circuit	no/diode
Operating temperature	-25 °C...+40 °C
Storage temperature	-40 °C...+85 °C
Approvals	CE;
Standards	EN 50178
Rated voltage	300 V
Rated impulse withstand voltage	4.0 kV
Creepage and clearance path input - output	≥ 4 mm
Surge category	III
Pollution severity	2

Rated voltage	24 V DC ±20 %
Rated current	4.7 mA
Power rating	max. 112 mW
max. input frequency	50 kHz
Auxiliary voltage	no
Status indicator	LED green
Output voltage	5 VTTL
Output current (max.)	8 mA, fan out = 20 LS-TTL
Voltage drop at max. load	
Block-state curr. (closed-circuit curr.)	
Switch-on delay/Switch-off delay	1 µs/2.5 µs
Short-circuit-proof/Protective circuit	no/diode
Operating temperature	-25 °C...+40 °C
Storage temperature	-25 °C...+85 °C
Approvals	CE;
Standards	EN 50178
Rated voltage	300 V
Rated impulse withstand voltage	4.0 kV
Creepage and clearance path input - output	≥ 5.5 mm
Surge category	III
Pollution severity	2

Rated voltage	24 V DC ±20 %
Rated current	13 mA AC/ 12 mA DC
Power rating	max.: 220 mVA / 195 mW
max. input frequency	≤ 10 Hz
Auxiliary voltage	no
Status indicator	LED *
Output voltage	24 V DC ±20%
Output current (max.)	2 A
Voltage drop at max. load	
Block-state curr. (closed-circuit curr.)	
Switch-on delay/Switch-off delay	2 ms/7 ms
Short-circuit-proof/Protective circuit	yes/
Operating temperature	-25 °C...+50 °C
Storage temperature	-40 °C...+85 °C
Approvals	CE;
Standards	EN 50178
Rated voltage	300 V
Rated impulse withstand voltage	6.0 kV
Creepage and clearance path input - output	≥ 5.5 mm
Surge category	III
Pollution severity	2

Dimensions	
Clamping range (rating- / min. / max.)	mm <sup>2</sup>
Length x width x height	mm
Note	

Screw connection	
Clamping range (rating- / min. / max.)	4 / 0.5 / 4
Length x width x height	65 x 6 x 57
Note	

Screw connection	
Clamping range (rating- / min. / max.)	4 / 0.5 / 4
Length x width x height	77 x 6 x 62
Note	

Screw connection	
Clamping range (rating- / min. / max.)	4 / 0.5 / 4
Length x width x height	77 x 6 x 62
* Status LED: green = OK, yellow = low load, blinking red = short-circuit	
Note	

**Ordering data**

Connection system	
	Screw connection
Note	

Type	(Qty.=1)	Order No.
DKO 35 24VDC E:O		8215630000
Input at top		

Type	(Qty.=1)	Order No.
DKO DK5 24VDC 50KHZ		8228640000
Input at top		

Type	(Qty.=1)	Order No.
DKO DK5 24VUC		8228630000
Input at bottom		

**Accessories**

Note	
End plate	AP DKT4 0687560000

Note	
End plate	AP DK 5 PA BE: 4036780000

Note	
End plate	AP DK 5 PA BE: 4036780000

Note	
End plate	AP DK 5 PA BE: 4036780000

Optos - DK-SERIES

Mini-coupler DKO

- Coupling of digital sensor/actuator signals between PLC and process
- Inexpensive solution for adapting level and potential
- Low input power
- Screw connection system
- 6 mm width
- For mounting on TS 35

48 V UC



115 V UC



230 V UC

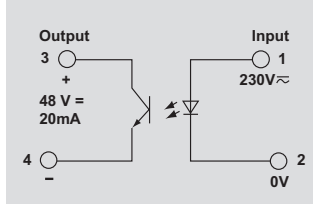
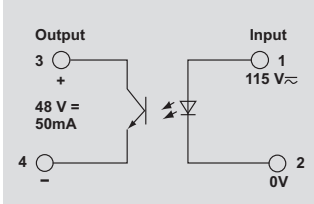
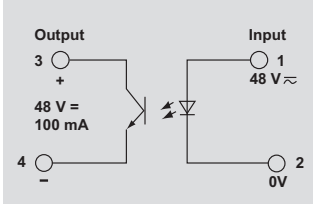

Technical data

Input

Rated voltage	48 V UC ±20 %
Rated current	3,2 mA AC / 2,8 mA DC
Power rating	max.: 155 mVA / 135 mW
max. input frequency	3 kHz
Auxiliary voltage	no
Status indicator	LED green

Output

Output voltage	5...48 V DC
Output current (max.)	100 mA
Voltage drop at max. load	≤ 1,5 V
Block-state curr. (closed-circuit curr.)	
Switch-on delay/Switch-off delay	5 ms/15 ms
Short-circuit-proof/Protective circuit	no/diode

General data

Operating temperature	-25 °C...+50 °C
Storage temperature	-40 °C...+85 °C
Approvals	CE;

Insulation coordination (EN 50 178)

Standards	EN 50178
Rated voltage	300 V
Rated impulse withstand voltage	4,0 kV
Creepage and clearance path input - output	≥ 4 mm
Surge category	III
Pollution severity	2

Dimensions

Clamping range (rating- / min. / max.)	mm²
Length x width x height	mm

Note

Screw connection

4 / 0,5 / 4
65 x 6 x 57

Screw connection

4 / 0,5 / 4
65 x 6 x 57

Screw connection

4 / 0,5 / 4
65 x 6 x 57

Ordering data

Connection system

Screw connection

Type	(Qty.=1)	Order No.
DKO 35 48VUC		8025910000

Type	(Qty.=1)	Order No.
DKO 35 115VUC		8077860000

Type	(Qty.=1)	Order No.
DKO 35 230VUC		8008160000

Note

Input below

Input at bottom

Input at bottom

Accessories

Note

End plate  
AP DK 4: 0687560000

End plate  
AP DKT 4: 0687560000

End plate  
AP DKT4 0687560000

### MiniConditioner MCZ O

- Universal interface between control and sensor/actuator
- Direct switching of load currents up to 2 A DC
- Tension clamp connection system
- Plug-in cross-connection
- Plug-in cross-connection
- Width 6mm

### 24 V UC

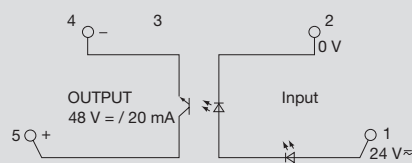

### 24 V UC / 24 V 2 A

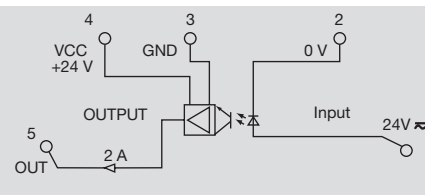

### Technical data

<b>Input</b>	
Rated voltage	24 V DC $\pm 20\%$
Rated current	11 mA AC / 9 mA DC
Power rating	230 mW / 280 mVA
max. input frequency	AC: 5 Hz / DC: 10 Hz
Auxiliary voltage	no
Status indicator	LED green
<b>Output</b>	
Output voltage	5...48 V DC
Output current (max.)	20 mA
Voltage drop at max. load	$\leq 1$ V
Block-state curr. (closed-circuit curr.)	
Switch-on delay/Switch-off delay	AC: 10 ms / DC: 20 ms / AC: 45 ms / DC: 40 ms
Short-circuit-proof/Protective circuit	no / Integrated free-wheel diode
<b>General data</b>	
Operating temperature	-25 °C...+50 °C
Storage temperature	-40 °C...+85 °C
Approvals	CSA;cURus;CE;
<b>Insulation coordination (EN 50 178)</b>	
Standards	EN 50178
Rated voltage	300 V
Rated impulse withstand voltage	6.0 kV
Creepage and clearance path input - output	$\geq 5.5$ mm
Surge category	III
Pollution severity	2
<b>Dimensions</b>	
Clamping range (rating- / min. / max.)	mm <sup>2</sup>
Length x width x height	mm
<b>Note</b>	

<b>Tension clamp connection</b>		
	1.5 / 0.5 / 1.5	
	91 x 6 x 64	
<b>Note</b>		

<b>Tension clamp connection</b>		
	1.5 / 0.5 / 1.5	
	91 x 6 x 64	
<b>Note</b>		
* Status LED: green = ok, yellow = low load, blinking red = short-circuit		

### Ordering data

<b>Connection system</b>	
	Tension clamp connection
<b>Note</b>	
<b>Accessories</b>	
<b>Note</b>	

Type	Qty.	Order No.
MCZ O 24VUC	10	8365940000
<b>Note</b>		
End plate AP MCZ 1.5: 8389030000 for cross-connectors and markers see MCZ Series accessories		

Type	Qty.	Order No.
MCZ O 24VUC	10	8287730000
<b>Note</b>		
End plate AP MCZ 1.5: 8389030000 for cross-connectors and markers see MCZ Series accessories		

## Optos - MCZ-SERIES

### MiniConditioner MCZ O

- Universal interface between control and sensor/actuator
- Tension clamp connection system
- Plug-in cross-connection
- Width 6mm

### 120 V UC



### 230 V AC

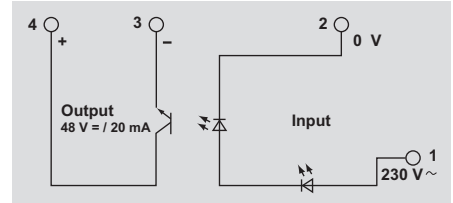
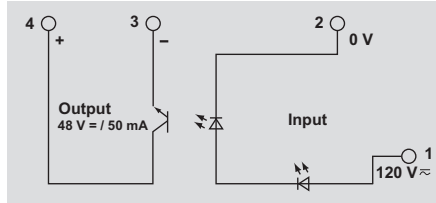

### Technical data

#### Input

Rated voltage	120 V UC +5/-15 %
Rated current	3 mA
Power rating	350 mW / 400 mVA
max. input frequency	AC: 5 Hz duty factor 1:2, DC: 20 Hz duty factor 1:2
Auxiliary voltage	no
Status indicator	LED green

#### Output

Output voltage	5...48 V DC
Output current (max.)	50 mA
Voltage drop at max. load	≤ 1,6 V
Block-state curr. (closed-circuit curr.)	0.16 mA
Switch-on delay/Switch-off delay	≤ 30 ms / ≤ 40 ms
Short-circuit-proof/Protective circuit	no /Integrated free-wheel diode

#### General data

Operating temperature	-25 °C...+40 °C
Storage temperature	-40 °C...+60 °C
Approvals	CSA;cURus;CE;

#### Insulation coordination (EN 50 178)

Standards	EN 50178
Rated voltage	300 V
Rated impulse withstand voltage	6.0 kV
Creepage and clearance path input - output	≥ 5.5 mm
Surge category	III
Pollution severity	2

Rated voltage	230 V AC +5 %/ -15 %
Rated current	10 mA
Power rating	2.3 VA
max. input frequency	AC: 5 Hz duty factor 1:2
Auxiliary voltage	no
Status indicator	LED green

Output voltage	5...48 V DC
Output current (max.)	20 mA
Voltage drop at max. load	≤ 1,6 V
Block-state curr. (closed-circuit curr.)	0.16 mA
Switch-on delay/Switch-off delay	≤ 30 ms / ≤ 40 ms
Short-circuit-proof/Protective circuit	no /Integrated free-wheel diode

Operating temperature	-25 °C...+40 °C
Storage temperature	-40 °C...+85 °C
Approvals	CSA;cURus;CE;

Standards	EN 50178
Rated voltage	300 V
Rated impulse withstand voltage	6.0 kV
Creepage and clearance path input - output	≥ 5.5 mm
Surge category	III
Pollution severity	2

#### Dimensions

Clamping range (rating- / min. / max.)	mm <sup>2</sup>
Length x width x height	mm

#### Note

#### Tension clamp connection

1.5 / 0.5 / 1.5
91 x 6 x 64

#### Tension clamp connection

1.5 / 0.5 / 1.5
91 x 6 x 64

### Ordering data

Connection system	Tension clamp connection
-------------------	--------------------------

Type	Qty.	Order No.
MCZ O 120VUC	10	8421060000

Type	Qty.	Order No.
MCZ O 230VAC	10	8421380000

#### Note

### Accessories

#### Note

End plate AP MCZ 1.5: 8389030000  
for cross-connectors and markers see MCZ Series accessories

End plate AP MCZ 1.5: 8389030000  
for cross-connectors and markers see MCZ Series accessories

### MiniConditioner MCZ O

Module can be used as an universal interface:

- Between control and actuator, to convert signals from 24 Vdc to 5 VTTL
- Between control and actuator, to convert signals from 5 VTTL to 5...48 Vdc

### 24 V DC / 5 V TTL

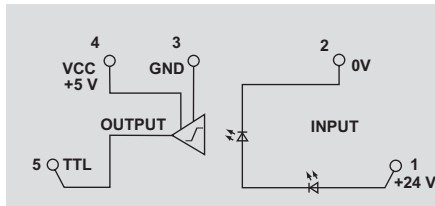

### 5 V TTL / 5...48 V DC

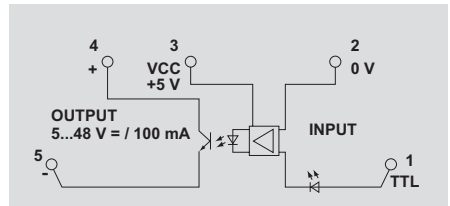

### Technical data

#### Input

Rated voltage	24 V DC $\pm$ 16 %
Rated current	4.7 mA
Power rating	112 mW
max. input frequency	100 kHz duty factor 1:2, 50 kHz duty factor 1:10
Auxiliary voltage	no
Status indicator	LED green

#### Output

Output voltage	5 V TTL(4.75...5.25 V)
Output current (max.)	8 mA, fan out = 20 LS-TTL
Voltage drop at max. load	
Block-state curr. (closed-circuit curr.)	
Switch-on delay/Switch-off delay	1 $\mu$ s (at 20 V DC) / 2.5 $\mu$ s (at 28 V DC)
Short-circuit-proof/Protective circuit	no /diode

#### General data

Operating temperature	-25 °C...+40 °C
Storage temperature	-40 °C...+60 °C
Approvals	CSA;cURus;CE;

#### Insulation coordination (EN 50 178)

Standards	EN 50178
Rated voltage	300 V
Rated impulse withstand voltage	6.0 kV
Creepage and clearance path input - output	$\geq$ 5.5 mm
Surge category	III
Pollution severity	2

#### Dimensions

Clamping range (rating- / min. / max.)	mm <sup>2</sup>
Length x width x height	mm

#### Note

#### Tension clamp connection

1.5 / 0.5 / 1.5
91 x 6 x 64

#### Tension clamp connection

1.5 / 0.5 / 1.5
91 x 6 x 64

### Ordering data

#### Connection system

Tension clamp connection

Type	Qty.	Order No.
MCZ O 24VDC	10	8324610000

Type	Qty.	Order No.
MCZ O 5VTTL	10	8398940000

#### Note

### Accessories

#### Note

End plate AP MCZ 1.5: 8389030000  
for cross-connectors and markers see MCZ Series accessories

End plate AP MCZ 1.5: 8389030000  
for cross-connectors and markers see MCZ Series accessories

## Optos - MCZ-TRAK-SERIES

### MCZ O TRAK

- Module for rail industry applications
- Meets requirements of EN 50155
- Power fluctuations -30 %/+25 %
- Operating temperature -25...+70 °C (85 °C / 10 min.) as per EN 50155
- Condensation permissible

### 24 V DC TRAK

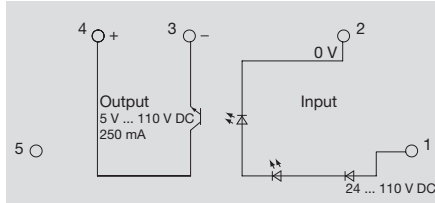

### Technical data

#### Input

Rated voltage  
Rated current  
Power rating  
max. input frequency  
Auxiliary voltage  
Status indicator

24...110 V DC -30/+25%  
1.9 mA @ 24 V DC 2.8 mA @ 110 V DC  
10 Hz  
no  
LED green

#### Output

Output voltage  
Output current (max.)  
Voltage drop at max. load  
Block-state curr. (closed-circuit curr.)  
Switch-on delay/Switch-off delay  
Short-circuit-proof/Protective circuit

5...137,5 V DC  
250 mA @ 50 °C ;180 mA @ 70 °C  
≤ 1.7 V  
10 ms /50 ms  
/Varistor, integral free-wheel diode

#### General data

Operating temperature  
Storage temperature  
Approvals

+85°C for 10 minutes ; -25 °C...+70 °C  
-40 °C...+85 °C  
CE;

#### Insulation coordination (EN 50 178)

Standards  
Rated voltage  
Rated impulse withstand voltage  
Creepage and clearance path input - output  
Surge category  
Pollution severity

EN 50178  
300 V  
6.0 kV  
≥ 5.5 mm  
III  
2

#### Dimensions

Clamping range (rating- / min. / max.) mm²  
Length x width x height mm

#### Tension clamp connection

1.5 / 0.5 / 1.5  
91 x 6 x 64

#### Note

### Ordering data

#### Connection system

Tension clamp connection

Type	Qty.	Order No.
MCZ O TRAK 24.110VDC	10	8820710000

#### Note

### Accessories

#### Note

End plate AP MCZ 1.5: 8389030000  
for cross-connectors and markers see MCZ Series accessories

**MCZ accessories**

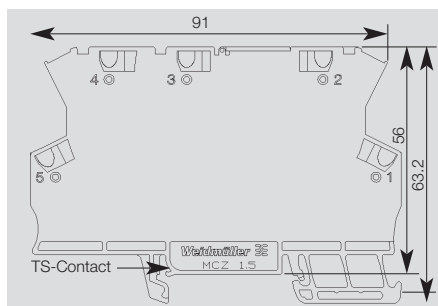

**Ordering data**

End plate
-----------

Type	Qty	Order No.
AP MCZ 1.5	50	8389030000



**Ordering data**

	No. of poles	Type	Qty	Order No.
Plug-in cross-connection, yellow	2	ZQV 4N / 2 GE	60	1758250000
Plug-in cross-connection, yellow	3	ZQV 4N / 3 GE	60	1762630000
Plug-in cross-connection, yellow	4	ZQV 4N / 4 GE	60	1762620000
Plug-in cross-connection, yellow	10	ZQV 4N / 10 GE	20	1758260000
Plug-in cross-connection, yellow	20	ZQV 4N / 20 GE	20	1909020000
Plug-in cross-connection, red	2	ZQV 4N / 2 RT	60	1793950000
Plug-in cross-connection, red	3	ZQV 4N / 3 RT	60	1793980000
Plug-in cross-connection, red	4	ZQV 4N / 4 RT	60	1794010000
Plug-in cross-connection, red	10	ZQV 4N / 10 RT	20	1794040000
Plug-in cross-connection, red	20	ZQV 4N / 20 RT	20	1909150000
Plug-in cross-connection, blue	2	ZQV 4N / 2 BL	60	1793960000
Plug-in cross-connection, blue	3	ZQV 4N / 3 BL	60	1793990000
Plug-in cross-connection, blue	4	ZQV 4N / 4 BL	60	1794020000
Plug-in cross-connection, blue	10	ZQV 4N / 10 BL	20	1794050000
Plug-in cross-connection, blue	20	ZQV 4N / 20 BL	20	1909100000
Plug-in cross-connection, black	2	ZQV 4N / 2 SW	60	1793970000
Plug-in cross-connection, black	3	ZQV 4N / 3 SW	60	1794000000
Plug-in cross-connection, black	4	ZQV 4N / 4 SW	60	1794030000
Plug-in cross-connection, black	10	ZQV 4N / 10 SW	20	1794060000
Plug-in cross-connection, black	20	ZQV 4N / 20 SW	20	1909120000



**Ordering data**

Marker
--------

Type	Qty	Order No.
WS10/6	200	1060960000

## Optos - MICROSERIES

### MOS / MOZ 0.1 A

Universal interface between control and sensor/actuator

- Plug-in cross-connection ZQV 4N
- Interchangeable solid-state relay
- 6.1 mm wide
- Screw or tension clamp connection
- For mounting on TS 35

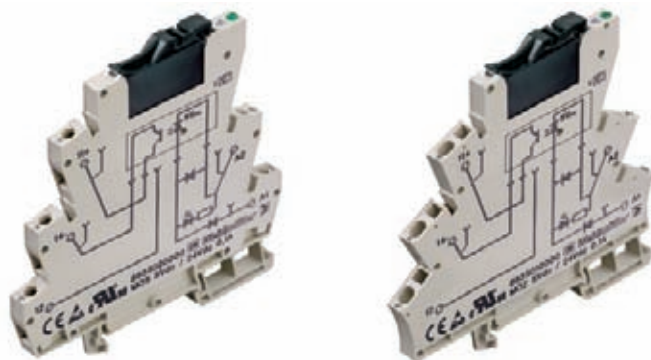

C

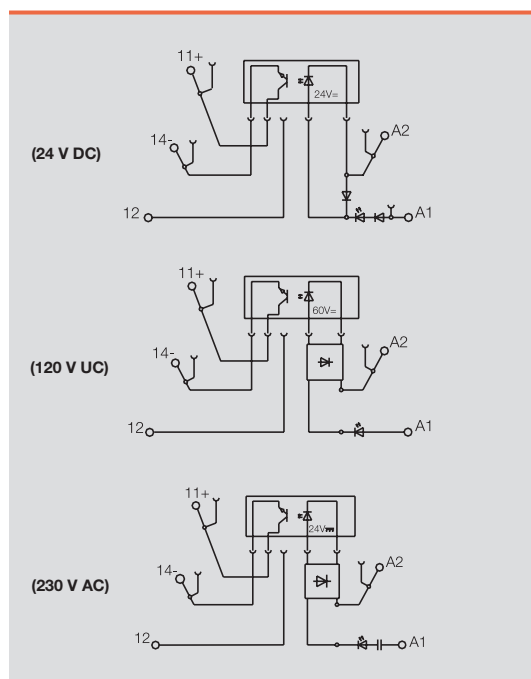

Output	
Output voltage	3...48 V DC
Output current (max.)	0.1 A
Voltage drop at max. load	≤ 1 V
Block-state curr. (closed-circuit curr.)	≤ 1 mA
Leakage current	≤ 1 mA
Short-circuit-proof/Protective circuit	no/Integrated free-wheel diode
General data	
Operating temperature	-25 °C...+50 °C
Storage temperature	-40 °C...+60 °C
Approvals	CE; cULus;
Insulation coordination (EN 50 178)	
Standards	EN 50178
Rated voltage	300 V
Rated impulse withstand voltage	4.0 kV
Creepage and clearance path input - output	≥ 5.5 mm
Surge category	III
Pollution severity	2
Dimensions	
Clamping range (rating- / min. / max.)	mm <sup>2</sup> 2.5 / 0.5 / 4
Length x width x height	mm 93 / 6.1 / 92
Note	
CE, UL/UR for mounting on TS 35	

#### Ordering data

Input	5 V DC / 24 V DC 0.1 A	24 V DC / 24 V DC 0.1 A	120 V UC / 24 V DC 0.1 A	230 V AC / 24 V DC 0.1 A
Rated voltage	5 V DC ±20%	24 V DC ±20 %	120 V UC + 10 %/ -15 %	230 V AC ±10%
Rated current	11 mA ±10 %	5,7 mA	3,4mA AC/2,8mA DC	7.4mA
Power rating	55 mW ±10 %	140 mW	340 mW / 0.4 VA	1.7 VA
max. input frequency	10 Hz	300 Hz	DC: 10 Hz /AC: 3 Hz	3 Hz
Switch-on delay	< 6,5 ms	35µs	< 6.5 ms	< 6.5 ms
Switch-off delay	< 10 ms	355µs	< 10 ms	< 10 ms

Ordering data Complete module		5 V DC / 24 V DC 0.1 A		24 V DC / 24 V DC 0.1 A		120 V UC / 24 V DC 0.1 A		230 V AC / 24 V DC 0.1 A	
Screw connection	Type	MOS 5Vdc / 24Vdc 0,1A		MOS 24Vdc / 24Vdc 0.1A		MOS 120Vuc / 24Vdc 0.1A		MOS 230Vac / 24Vdc 0.1A	
	Order No.	<b>8633020000</b>		<b>8607340000</b>		<b>8607690000</b>		<b>8607710000</b>	
Tension clamp connection	Type	MOZ 5Vdc / 24Vdc 0.1A		MOZ 24Vdc / 24Vdc 0,1A		MOZ 120Vuc / 24Vdc 0.1A		MOZ 230Vac / 24Vdc 0.1A	
	Order No.	<b>8633010000</b>		<b>8607360000</b>		<b>8607730000</b>		<b>8607750000</b>	
Ordering data Spare relay, pluggable		5 V DC / 24 V DC 0.1 A		24 V DC / 24 V DC 0.1 A		120 V UC / 24 V DC 0.1 A		230 V AC / 24 V DC 0.1 A	
	Type	SSS Relais 5V/24V 0,1ADC		SSS Relais 24V/24V 0,1Adc		SSS Relais 60V/24V 0,1ADC		SSS Relais 24V/24V 0,1Adc	
	Order No.	<b>4064320000</b>		<b>4061180000</b>		<b>4061230000</b>		<b>4061180000</b>	
<b>Note</b>									

**MOS / MOZ 1 A**

Universal interface between control and sensor/actuator

- Plug-in cross-connection ZQV 4N
- Interchangeable solid-state relay
- 6.1 mm wide
- Screw or tension clamp connection
- For mounting on TS 35

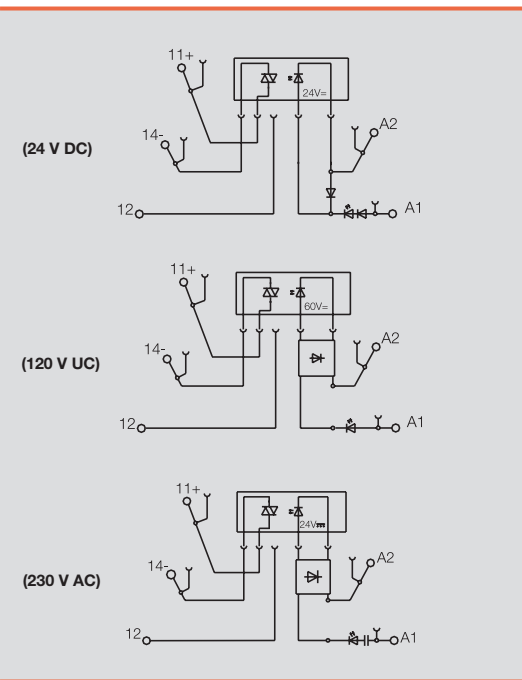
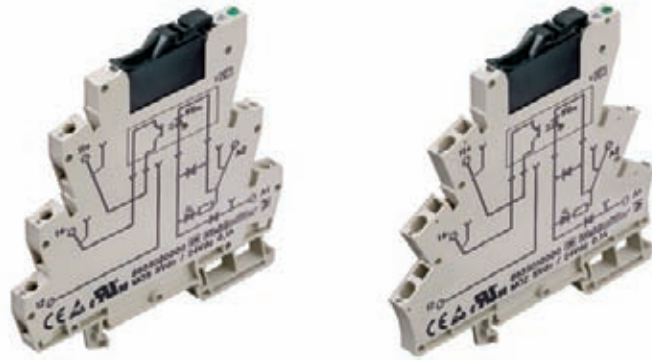

Output	
Output voltage	24...240 V AC
Output current (max.)	1 A
Voltage drop at max. load	approx. 1.6 V
Block-state curr. (closed-circuit curr.)	approx. 1.5 mA at 200 V
Leakage current	≤ 20 µA
Short-circuit-proof/Protective circuit	no/Integrated free-wheel diode
General data	
Operating temperature	-25 °C...+50 °C
Storage temperature	-40 °C...+60 °C
Approvals	CE; cULus;
Insulation coordination (EN 50 178)	
Standards	EN 50178
Rated voltage	300 V
Rated impulse withstand voltage	4.0 kV
Creepage and clearance path input - output	≥ 5.5 mm
Surge category	III
Pollution severity	2
Dimensions	
Clamping range (rating- / min. / max.)	mm <sup>2</sup> 2.5 / 0.5 / 4
Length x width x height	mm 93 / 6.1 / 92
Note	
CE, UL/UR for mounting on TS 35	

**Ordering data**

Input	24 V DC / 230 V AC 1 A	120 V UC / 230 V AC 1 A	230 V AC / 230 V AC 1 A	
Rated voltage	24 V DC ±20 %	120 V UC + 10 %/ -15 %	230 V UC ±10 %	
Rated current	10.4 mA ± 10%	2.5...3.8 mA	7.4 mA ±10 %	
Power rating	250 mW ± 15 %	0.4 VA ±15%	1,7 VA ± 20%	
max. input frequency	3 Hz	3 Hz	3 Hz	
Switch-on delay	< 11 ms	< 11 ms	< 20 ms	
Switch-off delay	< 11 ms	< 11 ms	< 20 ms	

**Ordering data**

Complete module					
Screw connection	Type	MOS 24Vdc/ 230VAC 1A	MOS 120Vuc / 230VAC 1A	MOS 230Vuc/ 230VAc 1A	
	Order No.	<b>8652010000</b>	<b>8651930000</b>	<b>8651990000</b>	
Tension clamp connection	Type	MOZ 24Vdc/ 230VAC 1A	MOZ 120Vuc / 230VAC 1A	MOZ 230Vuc/ 230VAC 1A	
	Order No.	<b>8652020000</b>	<b>8651950000</b>	<b>8651970000</b>	

**Ordering data**

Spare relay, pluggable					
	Type	SSS Relais 24V/230V 1Aac	SSS Relais 60V/230V 1Aac	SSS Relais 24V/230V 1Aac	
	Order No.	<b>4061210000</b>	<b>4061220000</b>	<b>4061210000</b>	

Note				

## Optos - MICROSERIES

### MOS / MOZ 2 A

Universal interface between control and sensor/actuator

- Plug-in cross-connection ZQV 4N
- Interchangeable solid-state relay
- 6.1 mm wide
- Screw or tension clamp connection
- For mounting on TS 35

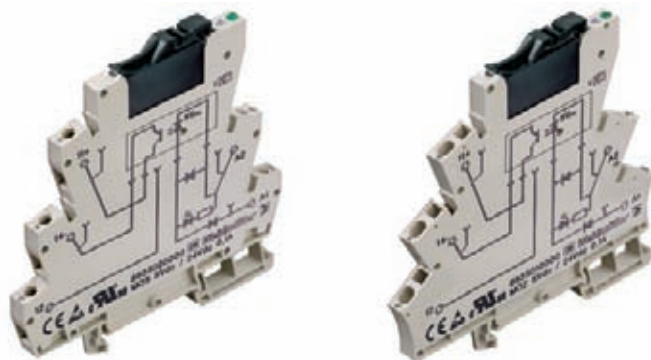

C

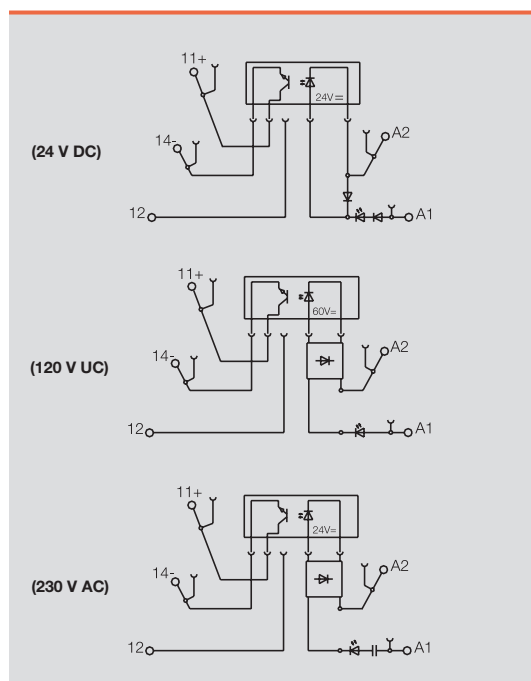

Output	
Output voltage	3...33 V DC
Output current (max.)	2 A
Voltage drop at max. load	≤ 120 mV
Block-state curr. (closed-circuit curr.)	approx. 10 µA
Leakage current	≤ 1 mA
Short-circuit-proof/Protective circuit	no/Integrated free-wheel diode
General data	
Operating temperature	-25 °C...+50 °C
Storage temperature	-40 °C...+60 °C
Approvals	CE; cULus;
Insulation coordination (EN 50 178)	
Standards	EN 50178
Rated voltage	300 V
Rated impulse withstand voltage	4.0 kV
Creepage and clearance path input - output	≥ 5.5 mm
Surge category	III
Pollution severity	2
Dimensions	
Clamping range (rating- / min. / max.)	mm <sup>2</sup> 2.5 / 0.5 / 4
Length x width x height	mm 93 / 6.1 / 92
Note	
CE, UL/UR for mounting on TS 35	

### Ordering data

Input	5 V DC / 24 V DC 2 A	24 V DC / 24 V DC 2 A	120 V UC / 24 V DC 2 A	230 V AC / 24 V DC 2 A
Rated voltage	5 V DC ±20%	24 V DC ±20 %	120 V UC + 10 % / -15 %	230 V AC ±10%
Rated current	11 mA DC ±10 %	5.7mA	3,4 mA AC/2,8 mA DC	7.4mA
Power rating	55 mW ±10 %	140 mW	340 mW / 0.4 VA	1.7 VA
max. input frequency	300 Hz	300 Hz	DC: 10 Hz / AC: 3 Hz	3 Hz
Switch-on delay	< 55 µs	< 55 µs	< 6.5 ms	< 6.5 ms
Switch-off delay	< 1 ms	< 1.2 ms	< 10 ms	< 10 ms

### Ordering data

Complete module					
Screw connection	Type	MOS 5Vdc / 24Vdc 2A	MOS 24Vdc / 24Vdc 2A	MOS 120Vuc / 24Vdc 2A	MOS 230Vac / 24Vdc 2A
	Order No.	8633000000	8607350000	8607700000	8607720000
Tension clamp connection	Type	MOZ 5Vdc / 24Vdc 2A	MOZ 24Vdc / 24Vdc 2A	MOZ 120Vuc / 24Vdc 2A	MOZ 230Vac / 24Vdc 2A
	Order No.	8632990000	8607370000	8607740000	8607760000

### Ordering data

Spare relay, pluggable					
Screw connection	Type	SSS Relais 5V/24V 2ADC	SSS Relais 24V/24V 2Acdc	SSS Relais 60V/24V 2Acdc	SSS Relais 24V/24V 2Acdc
	Order No.	4064310000	4061190000	4061200000	4061190000

Note					

**MOS / MOZ actuator version**

Universal interface between control and sensor/actuator

- Plug-in cross-connection ZQV 4N
- Interchangeable solid-state relay
- 6.1 mm wide
- Screw or tension clamp connection
- For mounting on TS 35

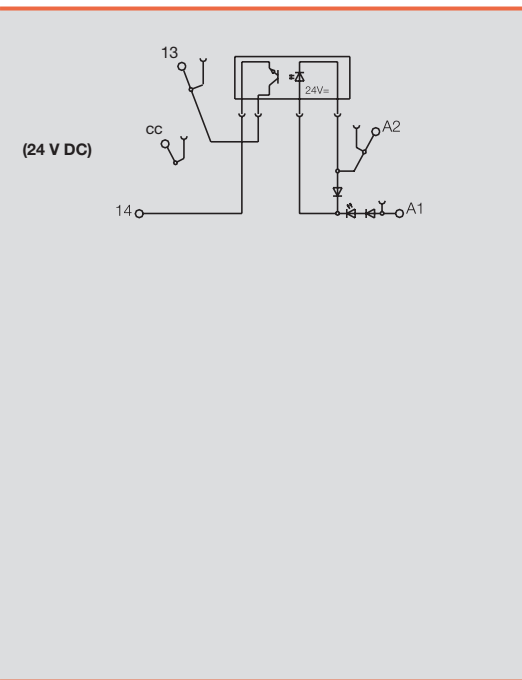
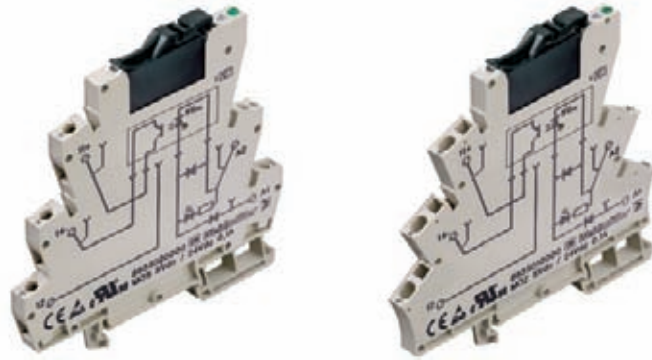

Output	
Output voltage	3...33 V DC
Output current (max.)	2 A
Voltage drop at max. load	≤ 120 mV
Block-state curr. (closed-circuit curr.)	approx. 10 µA
Short-circuit-proof/Protective circuit	no/Integrated free-wheel diode
General data	
Operating temperature	-25 °C...+50 °C
Storage temperature	-40 °C...+60 °C
Approvals	CE; cULus;
Insulation coordination (EN 50 178)	
Standards	EN 50178
Rated voltage	300 V
Rated impulse withstand voltage	4.0 kV
Creepage and clearance path input - output	≥ 5.5 mm
Surge category	III
Pollution severity	2
Dimensions	
Clamping range (rating- / min. / max.)	mm <sup>2</sup> 2.5 / 0.5 / 4
Length x width x height	mm 93 / 6.1 / 92
Note	
CE, UL/UR for mounting on TS 35	

Ordering data		24 V DC ACT			
Input					
Rated voltage		24 V DC ±20 %			
Rated current		5.7 mA ±10 %			
Power rating		140 mW ±10 %			
max. input frequency					
Switch-on delay		< 55 µs			
Switch-off delay		< 1,2 ms			
Ordering data Complete module					
Screw connection	Type	MOS 24Vdc / 24Vdc ACT			
	Order No.	<b>8676250000</b>			
Tension clamp connection	Type	MOZ 24Vdc / 24Vdc ACT			
	Order No.	<b>8676230000</b>			
Ordering data Spare relay, pluggable					
	Type	SSS Relais 24V/24V 2Acd			
	Order No.	<b>4061190000</b>			
Note					

**Optos – MICROSERIES**

**Plug-in solid-state relay**

**SSS Relay**

Switching current 100 mA

**SSS Relay**

Switching current 2 A

**SSS Relay**

Switching current 1 A



**Technical data**

Input	
Nominal control voltage	
Control voltage	min / max
Control current at $U_{IN} = 24\text{ V}$	
Drop-out voltage	
Control circuit resistance	
Output	
Switching voltage	
Switching/continuous current at $U_A > 5\text{ V DC}$	
Conducting-state voltage	
Insulation	
Test voltage between control/switching circuit	
Other data	
Operating temperature range	
Storage temperature range	
Weight	
Approvals	
* Ambient temperature 20 °C	
Wiring diagram	
For further data, see also <a href="http://em.tycoelectronics.com">http://em.tycoelectronics.com</a>	

24 V DC	60 V DC
Control voltage	16 V DC / 30 V DC
Control current at $U_{IN} = 24\text{ V}$	7 mA ± 10 %
Drop-out voltage	10 V DC
Control circuit resistance	approx. 4 kΩ
Switching voltage	3 ... 48 V DC
Switching/continuous current at $U_A > 5\text{ V DC}$	100 mA DC
Conducting-state voltage	< 1 V DC
Test voltage between control/switching circuit	2.5 kV
Operating temperature range	-20 °C ... +60 °C
Storage temperature range	-40 °C ... +70 °C
Weight	3.65 g
Approvals	

24 V DC	60 V DC
Control voltage	18 V DC / 30 V DC
Control current at $U_{IN} = 24\text{ V}$	7 mA ± 10 %
Drop-out voltage	10 V DC
Control circuit resistance	approx. 3,2 kΩ
Switching voltage	3 ... 33 V DC
Switching/continuous current at $U_A > 5\text{ V DC}$	2 A DC
Conducting-state voltage	< 120 mV DC
Test voltage between control/switching circuit	2.5 kV
Operating temperature range	-20 °C ... +60 °C
Storage temperature range	-40 °C ... +70 °C
Weight	3.65 g
Approvals	

24 V DC	60 V DC
Control voltage	18 ... 30 V DC
Control current at $U_{IN} = 24\text{ V}$	3.1 mA ± 10 %
Drop-out voltage	20 V DC
Control circuit resistance	20 kΩ
Switching voltage	24 ... 240 V AC
Switching/continuous current at $U_A > 5\text{ V DC}$	1 A AC
Conducting-state voltage	< 1 V AC
Test voltage between control/switching circuit	2.5 kV
Operating temperature range	-20 °C ... +60 °C
Storage temperature range	-40 °C ... +70 °C
Weight	3.65 g
Approvals	

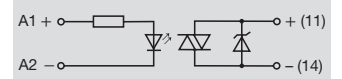
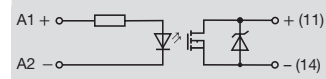
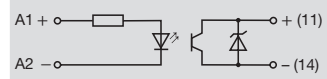

**Ordering data**

Type	Order No.
SSS Relais 5 V/24 V 0,1 A DC	4064320000
SSS Relais 24 V/24 V 0,1 A DC	4061180000
SSS Relais 60 V/24 V 0,1 A DC	4061230000

Type	Order No.
SSS Relais 5 V / 24 V 2 A DC	4064310000
SSS Relais 24 V/24 V 2 A DC	4061190000
SSS Relais 60 V/24 V 2 A DC	4061200000

Type	Order No.
SSS Relais 24 V/230 V 1 A AC	4061210000
SSS Relais 60 V/230 V 1 A AC	4061220000

**Dimensions**

**Printing details**

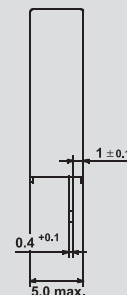
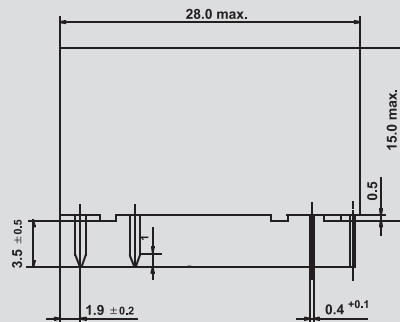
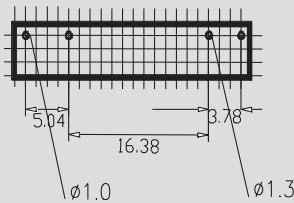

Accessories

General data – MICROSERIES

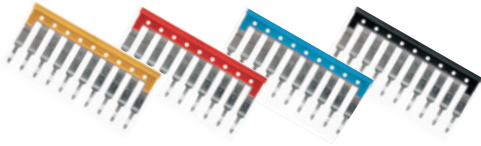

Plug-in cross-connection

Type	No. of poles	Qty	Order No.
<b>yellow</b>			
ZQV 4N / 2 GE	2	60	1758250000
ZQV 4N / 3 GE	3	60	1762630000
ZQV 4N / 4 GE	4	60	1762620000
ZQV 4N / 10 GE	10	20	1758260000
ZQV 4N / 20	20	20	1909020000
<b>red</b>			
ZQV 4N / 2 RT	2	60	1793950000
ZQV 4N / 3 RT	3	60	1793980000
ZQV 4N / 4 RT	4	60	1794010000
ZQV 4N / 10 RT	10	20	1794040000
ZQV 4N / 20 RT	20	20	1909150000
<b>blue</b>			
ZQV 4N / 2 BL	2	60	1793960000
ZQV 4N / 3 BL	3	60	1793990000
ZQV 4N / 4 BL	4	60	1794020000
ZQV 4N / 10 BL	10	20	1794050000
ZQV 4N / 20 BL	20	20	1909100000
<b>black</b>			
ZQV 4N / 2 SW	2	60	1793970000
ZQV 4N / 3 SW	3	60	1794000000
ZQV 4N / 4 SW	4	60	1794030000
ZQV 4N / 10 SW	10	20	1794060000
ZQV 4N / 20 SW	20	20	1909120000

Technical data

Conductor		Tension clamp connection	Screw connection
Solid H07V-U	mm <sup>2</sup>	0.5 ... 2.5	0.5 ... 4.0
Stranded H07V-K	mm <sup>2</sup>	0.5 ... 2.5	0.5 ... 2.5
"f" with wire end ferrules to DIN 46228-1	mm <sup>2</sup>	0.5 ... 1.5	0.5 ... 1.5
"f" with wire end ferrules with plastic collar	mm <sup>2</sup>	0.5 ... 1.5	0.5 ... 1.5
Max. clamping range	mm <sup>2</sup>	0.13 ... 2.5	0.13 ... 4.0
Plug gauge to IEC 60947-1	size	A 2	A 3
<b>General technical data</b>			
Nominal torque		-	0.6
Continuous current for 2-pole cross-connection	A	10	10
Continuous current for multi-pole cross-connection	A	10	10
Stripping length	mm	10	7
Ingress protection class		IP 20	IP 20
Housing material		Wemid	Wemid
UL 94 flammability rating		V-0	V-0
Nominal current	A	6	6
Nominal voltage	V	250	250

Other accessories

Type		Qty	Order No.
<b>Base only</b>			
MRZ 24VDC 1CO BASIS		10	8826000000
MRS 24VDC 1CO BASIS		10	8826010000
MRZ 120VUC 1CO BASIS		10	8826020000
MRS 120VUC 1CO BASIS		10	8826030000
MRZ 230VAC 1CO BASIS		10	8826040000
MRS 230VAC 1CO BASIS		10	8826050000
<b>Markers</b>			
WS 12/6	12 x 6 mm	200	1061160000
<b>Labels, Lasermark</b>			
LM MT 300 15/6 ge	484 labels / sheet	10	1686360000
<b>Screwdriver</b>			
SD 0,6 x 3,5 x 100		10	9008330000

Dimensions

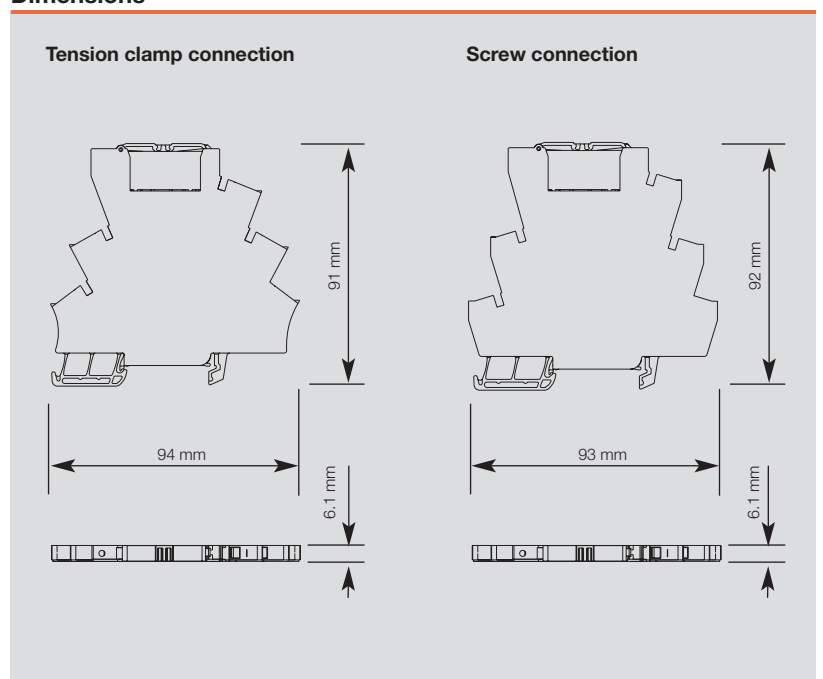

## Optos - PLUGSERIES

### POS / POZ

Universal interface between control and sensor

- Plug-in cross-connection ZQV 2.5N
- Interchangeable solid-state relay
- Screw or tension spring connection
- For mounting on TS 35

### 24 V DC / 24 V DC 2.5 A

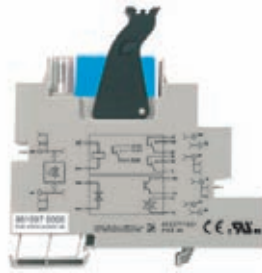

### 24 V DC / 24 V DC 5 A

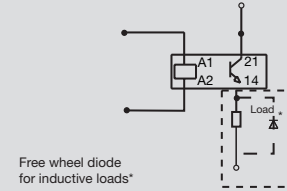
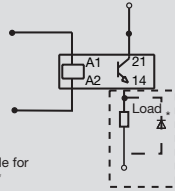
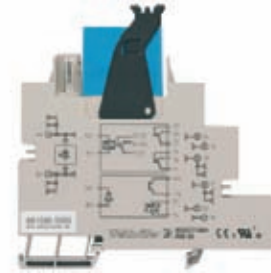

### Technical data

#### Input

Rated voltage  
Rated current  
Power rating  
Auxiliary voltage  
Status indicator

15 V DC...30 V DC  
approx. 10 mA  
250 mW  
no  
green LED

15 V DC...30 V DC  
approx. 10 mA  
250 mW  
no  
green LED

#### Output

Output voltage  
Output current (max.)  
Voltage drop at max. load  
Block-state curr. (closed-circuit curr.)  
Switch-on delay/Switch-off delay  
Short-circuit-proof/Protective circuit

0...30 V DC  
2.5 A  
≤ 0,4 V  
≤ 1 mA  
2ms /18ms  
no /Integrated free-wheel diode

0...30 V DC  
5 A  
≤ 0,3 V  
≤ 1 mA  
2ms /18ms  
no /Integrated free-wheel diode

#### General data

Operating temperature  
Storage temperature  
Approvals

-40 °C...+50 °C  
-40 °C...+ 50 °C  
CE;cURus;

-40 °C...+50 °C  
-40 °C...+ 50 °C  
CE;cURus;

#### Insulation coordination (EN 50 178)

Standards  
Rated voltage  
Rated impulse withstand voltage  
Creepage and clearance path input - output  
Surge category  
Pollution severity

EN 50178  
300 V  
2,5 kV<sub>eff</sub>  
8 mm  
III  
2

EN 50178  
300 V  
2,5 kV<sub>eff</sub>  
8 mm  
III  
2

#### Dimensions

Clamping range (rating- / min. / max.) mm<sup>2</sup>  
Length x width x height mm

#### Screw connection

2,5 / 0,5 / 2,5  
92 x 15,3 x 95

#### Tension clamp connection

2,5 / 0,5 / 2,5  
92 x 15,3 x 87

#### Screw connection

2,5 / 0,5 / 2,5  
92 x 15,3 x 95

#### Tension clamp connection

2,5 / 0,5 / 2,5  
92 x 15,3 x 87

#### Note

### Ordering data

#### Connection system

Screw connection  
Tension clamp connection

Type	Qty.	Order No.
POS 24VDC/24VDC 2A	10	8610840000
POZ 24VDC/24VDC 2A	10	8610920000

Type	Qty.	Order No.
POS 24VDC/24VDC 5A	10	8610900000
POZ 24VDC/24VDC 5A	10	8610970000

#### Note

Spare SSR 8576340000

Spare SSR 8576350000

### Accessories

#### Note

Cross-connectors and markers - see PLUGSERIES accessories

Cross-connectors and markers - see PLUGSERIES accessories

**POS / POZ**

Universal interface between control and sensor

- Plug-in cross-connection ZQV 2.5N
- Interchangeable solid-state relay
- Screw or tension spring connection
- For mounting on TS 35

**24 V DC / 230 V AC 2 A**

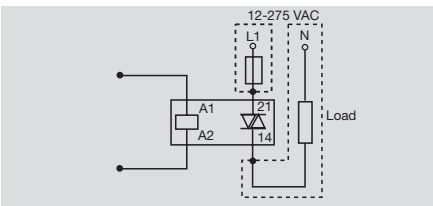
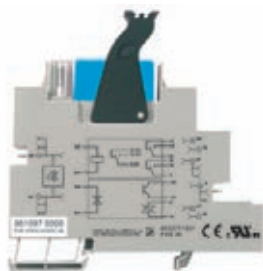

**24 V DC / 230 V AC 4 A**

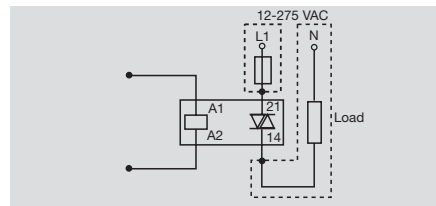
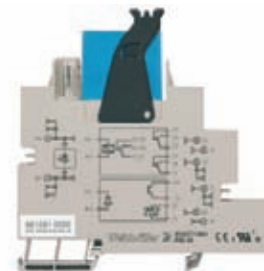

**Technical data**

<b>Input</b>	
Rated voltage	15 V DC...30 V DC
Rated current	approx. 10 mA
Power rating	250 mW
Auxiliary voltage	no
Status indicator	green LED
<b>Output</b>	
Output voltage	12...275 V AC
Output current (max.)	2 A
Voltage drop at max. load	≤ 1 V
Block-state curr. (closed-circuit curr.)	≤ 1 mA
Switch-on delay/Switch-off delay	12ms /20ms
Short-circuit-proof/Protective circuit	no /RC element
<b>General data</b>	
Operating temperature	-40 °C...+50 °C
Storage temperature	-40 °C...+ 50 °C
Approvals	CE;cURus;
<b>Insulation coordination (EN 50 178)</b>	
Standards	EN 50178
Rated voltage	300 V
Rated impulse withstand voltage	4,0 kV <sub>eff</sub>
Creepage and clearance path input - output	8 mm
Surge category	III
Pollution severity	2
<b>Dimensions</b>	
Clamping range (rating- / min. / max.)	mm <sup>2</sup>
Length x width x height	mm
<b>Note</b>	

<b>Screw connection</b>		<b>Tension clamp connection</b>	
Rated voltage	15 V DC...30 V DC	Rated voltage	15 V DC...30 V DC
Rated current	approx. 10 mA	Rated current	approx. 10 mA
Power rating	250 mW	Power rating	250 mW
Auxiliary voltage	no	Auxiliary voltage	no
Status indicator	green LED	Status indicator	green LED
Output voltage	12...275 V AC	Output voltage	12...275 V AC
Output current (max.)	2 A	Output current (max.)	3 A (4 A at 20°C)
Voltage drop at max. load	≤ 1 V	Voltage drop at max. load	≤ 1,1 V
Block-state curr. (closed-circuit curr.)	≤ 1 mA	Block-state curr. (closed-circuit curr.)	≤ 1 mA
Switch-on delay/Switch-off delay	12ms /20ms	Switch-on delay/Switch-off delay	12ms /20ms
Short-circuit-proof/Protective circuit	no /RC element	Short-circuit-proof/Protective circuit	no /RC element
Operating temperature	-40 °C...+50 °C	Operating temperature	-40 °C...+50 °C
Storage temperature	-40 °C...+ 50 °C	Storage temperature	-40 °C...+ 50 °C
Approvals	CE;cURus;	Approvals	CE;cURus;
Standards	EN 50178	Standards	EN 50178
Rated voltage	300 V	Rated voltage	300 V
Rated impulse withstand voltage	4,0 kV <sub>eff</sub>	Rated impulse withstand voltage	4,0 kV <sub>eff</sub>
Creepage and clearance path input - output	8 mm	Creepage and clearance path input - output	8 mm
Surge category	III	Surge category	III
Pollution severity	2	Pollution severity	2
<b>Screw connection</b>		<b>Tension clamp connection</b>	
Clamping range (rating- / min. / max.)	2,5 / 0,5 / 2,5	Clamping range (rating- / min. / max.)	2,5 / 0,5 / 2,5
Length x width x height	92 x 15,3 x 95	Length x width x height	92 x 15,3 x 87
<b>Note</b>		<b>Note</b>	

<b>Screw connection</b>		<b>Tension clamp connection</b>	
Rated voltage	15 V DC...30 V DC	Rated voltage	15 V DC...30 V DC
Rated current	approx. 10 mA	Rated current	approx. 10 mA
Power rating	250 mW	Power rating	250 mW
Auxiliary voltage	no	Auxiliary voltage	no
Status indicator	green LED	Status indicator	green LED
Output voltage	12...275 V AC	Output voltage	12...275 V AC
Output current (max.)	3 A (4 A at 20°C)	Output current (max.)	3 A (4 A at 20°C)
Voltage drop at max. load	≤ 1,1 V	Voltage drop at max. load	≤ 1,1 V
Block-state curr. (closed-circuit curr.)	≤ 1 mA	Block-state curr. (closed-circuit curr.)	≤ 1 mA
Switch-on delay/Switch-off delay	12ms /20ms	Switch-on delay/Switch-off delay	12ms /20ms
Short-circuit-proof/Protective circuit	no /RC element	Short-circuit-proof/Protective circuit	no /RC element
Operating temperature	-40 °C...+50 °C	Operating temperature	-40 °C...+50 °C
Storage temperature	-40 °C...+ 50 °C	Storage temperature	-40 °C...+ 50 °C
Approvals	CE;cURus;	Approvals	CE;cURus;
Standards	EN 50178	Standards	EN 50178
Rated voltage	300 V	Rated voltage	300 V
Rated impulse withstand voltage	4,0 kV <sub>eff</sub>	Rated impulse withstand voltage	4,0 kV <sub>eff</sub>
Creepage and clearance path input - output	8 mm	Creepage and clearance path input - output	8 mm
Surge category	III	Surge category	III
Pollution severity	2	Pollution severity	2
<b>Screw connection</b>		<b>Tension clamp connection</b>	
Clamping range (rating- / min. / max.)	2,5 / 0,5 / 2,5	Clamping range (rating- / min. / max.)	2,5 / 0,5 / 2,5
Length x width x height	92 x 15,3 x 95	Length x width x height	92 x 15,3 x 87
<b>Note</b>		<b>Note</b>	

**Ordering data**

<b>Connection system</b>	
Screw connection	
Tension clamp connection	
<b>Note</b>	

Type	Qty.	Order No.
POS 24VDC/230VAC 2A	10	8610860000
POZ 24VDC/230VAC 2A	10	8610930000
<b>Note</b>		
Spare SSR	8576370000	

Type	Qty.	Order No.
POS 24VDC/230VAC 4A	10	8610910000
POZ 24VDC/230VAC 4A	10	8610980000
<b>Note</b>		
Spare SSR	8576360000	

**Accessories**

<b>Note</b>	Cross-connectors and markers - see PLUGSERIES accessories
-------------	-----------------------------------------------------------

<b>Note</b>	Cross-connectors and markers - see PLUGSERIES accessories
-------------	-----------------------------------------------------------

<b>Note</b>	Cross-connectors and markers - see PLUGSERIES accessories
-------------	-----------------------------------------------------------

# Optos - PLUGSERIES

## POS / POZ

Universal interface between control and sensor

- Plug-in cross-connection ZQV 2.5N
- Interchangeable solid-state relay
- Screw or tension spring connection
- For mounting on TS 35

## 24 V DC / 24 V UC 1 A

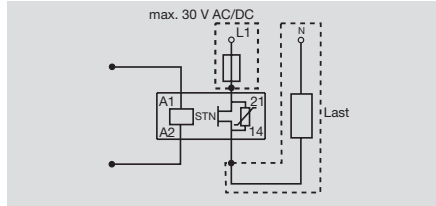
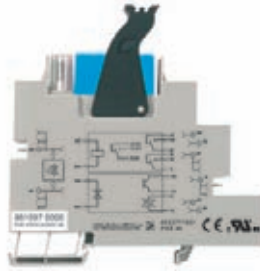

### Technical data

#### Input

Rated voltage	15 V DC...30 V DC
Rated current	approx. 10 mA
Power rating	250 mW
Auxiliary voltage	no
Status indicator	green LED

#### Output

Output voltage	0...30 V UC
Output current (max.)	1 A
Voltage drop at max. load	≤ 0,9 V
Block-state curr. (closed-circuit curr.)	≤ 1 mA
Switch-on delay/Switch-off delay	5ms /12ms
Short-circuit-proof/Protective circuit	no /Integrated free-wheel diode

#### General data

Operating temperature	-40 °C...+50 °C
Storage temperature	-40 °C...+ 50 °C
Approvals	CE;cURus;

#### Insulation coordination (EN 50 178)

Standards	EN 50178
Rated voltage	300 V
Rated impulse withstand voltage	4,0 kV <sub>eff</sub>
Creepage and clearance path input - output	8 mm
Surge category	III
Pollution severity	2

#### Dimensions

Clamping range (rating- / min. / max.)	mm <sup>2</sup>
Length x width x height	mm

#### Note

#### Screw connection

2,5 / 0,5 / 2,5
92 x 15,3 x 95

#### Tension clamp connection

2,5 / 0,5 / 2,5
92 x 15,3 x 87

### Ordering data

#### Connection system

Screw connection
Tension clamp connection

Type	Qty.	Order No.
POS 24VDC/24VUC 1A	10	8610890000
POZ 24VDC/24VUC 1A	10	8610960000

#### Note

Spare SSR 8576380000

### Accessories

#### Note

Cross-connectors and markers - see PLUGSERIES accessories

### Derating curves

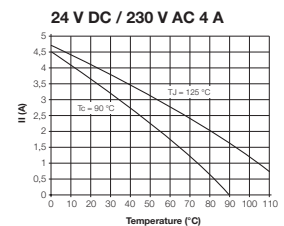
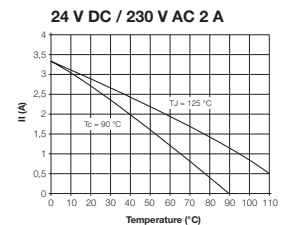
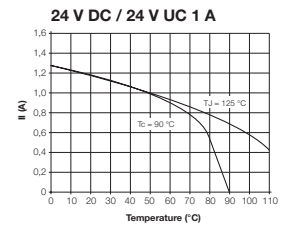
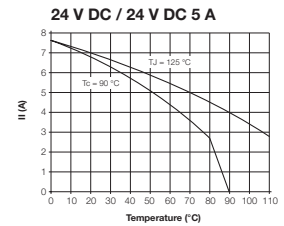
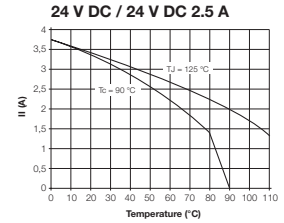

Accessories

PLUGSERIES

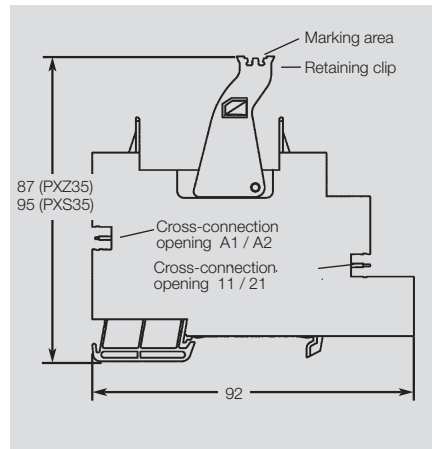

Technical data

Base without relay	
Nominal current	16 A
Nominal voltage	250 V
Dielectric strength coil/contact	> 4 kV
Ingress protection class	IP 20
Nominal cross-section	2.5 mm <sup>2</sup>
Stripping length	8 mm
	10 mm
Ambient temperature	-40 °C ... +60 °C
UL 94 flammability rating	V-0

Ordering data

Base for mounting on TS 35 rail			
Screw connection	PXS35	10	8533771001
Tension clamp connection	PZX35	10	8536691001

Retaining clip			
PRC	100	8536700000	

LED indicator with free-wheel diode			
6 ... 24 V DC	PLED 24 V DC	20	8536710000
red LED, 6 ... 24 V DC	PLED 24 V DC red	20	8611010000
48 ... 60 V DC	PLED 48 V DC	20	8536720000
115 V DC	PLED 115 V DC	20	8536730000
12 ... 24 V AC	PLED 24 V AC	20	8536750000
115 V AC	PLED 120 V AC	20	8536760000
230 V AC	PLED 230 V AC	20	8536780000
RC combination, 120 ... 230 V AC/DC	PLRC 200 nF/200 Ω	20	8566530000

Plug-in cross-connections			
2-pole	black	ZQV 2.5N/4-2SW	60 1784270000
	red	ZQV 2.5N/4-2RT	60 1784280000
	blue	ZQV 2.5N/4-2BL	60 1784290000

Markers			
	10 x 5 mm	WS 10/5	200 1060860000
	15 x 5 mm	WS 15/5	96 1609880000

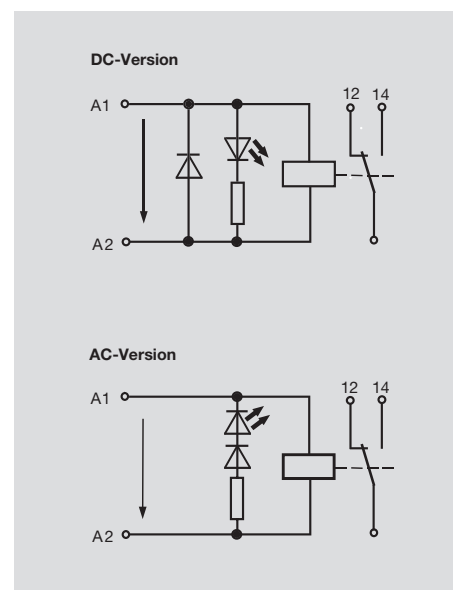
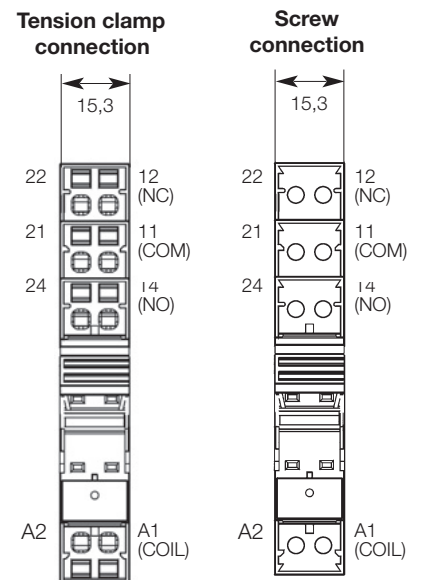

## Optos - RSO-SERIES

### RSO 30

- Plug-in connections
- DC output up to 3 A @ 5...60 V DC
- AC output up to 3 A @ 24...240 V AC
- 11 mm wide

### RSO 30-DV/SC



### RSO 30-DV/SA

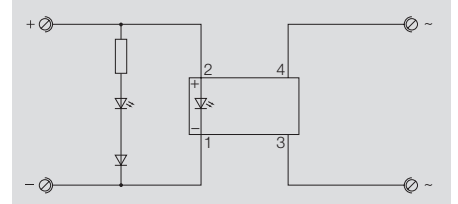
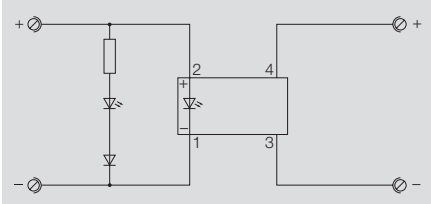

### Technical data

#### Input

Rated voltage  
Rated current  
Power rating  
Auxiliary voltage  
Status indicator

5...24 V DC  $\pm$  20%  
5...35 mA  
  
no  
LED green

5...24 V DC  $\pm$  20%  
5...35 mA  
  
no  
LED green

#### Output

Output voltage  
Output current (max.)  
Voltage drop at max. load  
Block-state curr. (closed-circuit curr.)  
Switch-on delay/Switch-off delay  
Short-circuit-proof/Protective circuit

2...60 V DC  
3 A  
  
 $\leq$  1 mA  
0.1 ms / 0.75 ms  
no /

24...250 V AC  
3 A  
1.6 V  
 $\leq$  5 mA  
Zero-voltage switch /  
no /

#### General data

Operating temperature  
Storage temperature  
Approvals

-25 °C...+40 °C  
-40 °C...+85 °C  
CE;

-25 °C...+40 °C  
-40 °C...+85 °C  
CE;

#### Insulation coordination (EN 50 178)

Standards  
Rated voltage  
Rated impulse withstand voltage  
Creepage and clearance path input - output  
Surge category  
Pollution severity

EN 50178  
300 V  
4.0 kV  
 $\geq$  8 mm  
III  
2

EN 50178  
300 V  
4.0 kV  
 $\geq$  8 mm  
III  
2

#### Dimensions

Clamping range (rating- / min. / max.) mm<sup>2</sup>  
Length x width x height mm

2.5 / 0.5 / 2.5  
80 x 11 x 50

2.5 / 0.5 / 2.5  
80 x 11 x 50

#### Note

### Ordering data

#### Connection system

Type	Qty.	Order No.
RSO 30/DV 5-24V CC/SC	20	9443100000

Type	Qty.	Order No.
RSO 30/DV 5-24V CC/SA	20	9443110000

#### Note

### Accessories

#### Note

**RSO 31**

- Plug-in connections
- DC output up to 3 A @ 5...60 V DC
- AC output up to 3 A @ 24...240 V AC
- 12.5 mm wide
- Plug-in fuse in output circuit

**RSO 31 -ODC/F**



**RSO 31 -OAC/F**

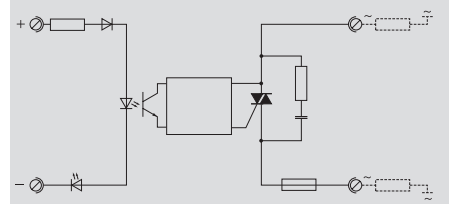
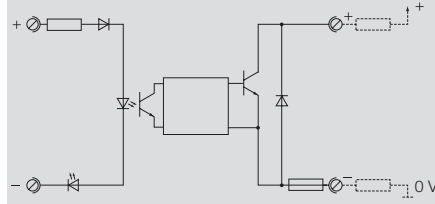

**Technical data**

**Input**

Rated voltage  
Rated current  
Power rating  
Auxiliary voltage  
Status indicator

24 V DC ±10%  
0.29 W  
no  
LED red

24 V DC ±10%  
0.29 W  
no  
LED red

**Output**

Output voltage  
Output current (max.)  
Voltage drop at max. load  
Block-state curr. (closed-circuit curr.)  
Switch-on delay/Switch-off delay  
Short-circuit-proof/Protective circuit

5...50 V DC  
3 A  
1.6 V  
≤ 1 mA  
0.1 ms /0.75 ms  
no /

24...250 V AC  
3 A  
1.6 V  
≤ 5 mA  
Zero-voltage switch /  
no /

**General data**

Operating temperature  
Storage temperature  
Approvals

-25 °C...+40 °C  
-40 °C...+85 °C  
CE;

-25 °C...+40 °C  
-40 °C...+85 °C  
CE;

**Insulation coordination (EN 50 178)**

Standards  
Rated voltage  
Rated impulse withstand voltage  
Creepage and clearance path input - output  
Surge category  
Pollution severity

EN 50178  
300 V  
4.0 kV  
≥ 8 mm  
III  
2

EN 50178  
300 V  
4.0 kV  
≥ 8 mm  
III  
2

**Dimensions**

Clamping range (rating- / min. / max.) mm²  
Length x width x height mm

2.5 / 0.5 / 2.5  
80 x 12.5 x 65.5

2.5 / 0.5 / 2.5  
80 x 12.5 x 65.5

**Note**

**Ordering data**

**Connection system**

Type	Qty.	Order No.
RSO31-ODC24/F	20	9430820000

Type	Qty.	Order No.
RSO31-OAC24/F	20	9430320000

**Note**

**Accessories**

**Note**

**Optos - WAVESERIES**

**Output voltage 5-48 V DC  
wide input range**



**C**

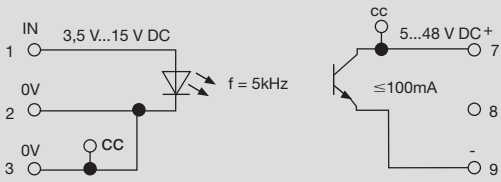

<b>Output</b>	
Output voltage	5 V DC ... 48 V DC
Output current (max.)	100 mA
Voltage drop at max. load	
Block-state curr. (closed-circuit curr.)	
Switch-on delay/Switch-off delay	8 μs/35 μs
Short-circuit-proof/Protective circuit	no/Varistor, integral free-wheel diode
<b>General data</b>	
Operating temperature	-25°C...+60°C
Storage temperature	-40 °C...+85 °C
Approvals	CSA;cURus;CE;
<b>Insulation coordination (EN 50 178)</b>	
Standards	EN 50178
Rated voltage	300 V
Rated impulse withstand voltage	6.0 kV
Creepage and clearance path input - output	≥ 5.5 mm
Surge category	III
Pollution severity	2

<b>Dimensions</b>	<b>Screw connection</b>	<b>Tension clamp connection</b>
Clamping range (rating- / min. / max.)	mm <sup>2</sup> 1.5 / 0.5 / 2.5	
Length x width x height	mm 72 / 22.5 / 92.4	

**Note** Cross-connectors and markers - see WAVESERIES accessories

**Ordering data**

<b>Input</b>	<b>3.5-15 V DC 5 KHZ</b>			
Rated voltage	3.5 V DC...15 V DC			
Rated current	10 ... 25 mA			
Power rating	32 ... 375 mW			
Auxiliary voltage	no			
Status indicator	LED green in output			

<b>Ordering data Complete module</b>				
Screw connection	Type WOS1 3.5-15VDC 5KHZ			
	Order No. <b>8275390000</b>			
Tension clamp connection	Type			
	Order No.			

<b>Ordering data Spare relay, pluggable</b>				
	Type			
	Order No.			

<b>Note</b>				

**Output voltage 24 V DC 0.5 A  
short-circuit-proof and protected  
against overload**



Derating curve

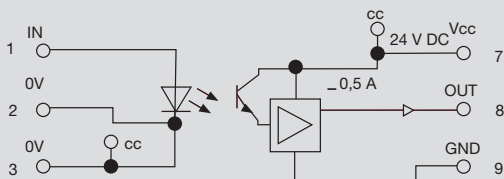
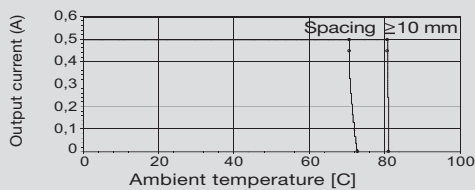

Output	
Output voltage	12 V DC ... 24 V DC... 28 V DC
Output current (max.)	500 mA
Voltage drop at max. load	
Block-state curr. (closed-circuit curr.)	
Switch-on delay/Switch-off delay	approx. 10 ms/approx. 20 ms
Short-circuit-proof/Protective circuit	Yes/max. 96 h/Varistor, polarity reversal protection
General data	
Operating temperature	-25°C...+60°C
Storage temperature	-40 °C...+85 °C
Approvals	CSA;cURus;CE;
Insulation coordination (EN 50 178)	
Standards	EN 50178
Rated voltage	300 V
Rated impulse withstand voltage	6.0 kV
Creepage and clearance path input - output	≥ 5.5 mm
Surge category	III
Pollution severity	2
Dimensions	
Clamping range (rating- / min. / max.)	mm <sup>2</sup> 1.5 / 0.5 / 2.5
Length x width x height	mm 72 / 22.5 / 92.4
Note	
Cross-connectors and markers - see WAVESERIES accessories	

**Ordering data**

Input	12 V UC / 24 V DC 0.5 A	15-60 V DC 1 kHz	115 V UC / 24 V DC 0.5 A	230 V UC / 24 V DC 0.5 A
Rated voltage	10 V DC...12 V DC...14 V DC	15 V DC...60 V DC	115 V UC, max. 130 V UC	230 V UC, max. 250 V UC
Rated current	15 mA AC / 12 mA DC	1.4 ... 4.1 mA	2,9 mA AC / 3,1 mA DC	11,5 mA AC / 1,8 mA DC
Power rating	0.18 VA / 0.14 W	21 ... 246 mW	0.16 VA / 0.23 W	2,6 VA / 0.4 W
Auxiliary voltage	no	no	no	no
Status indicator	LED green in output	LED green in output	LED green in output	LED green in output

Ordering data Complete module				
Screw connection Type	WOS1 12VUC	WOS1 15-60VDC 1KHZ	WOS1 115VUC	WOS1 230VUC
Order No.	8275500000	8237730000	8235180000	8275380000
Tension clamp connection Type				
Order No.				
Ordering data Spare relay, pluggable				
Type				
Order No.				
Note				

# Optos - WAVESERIES

## Output voltage 24 V DC 5 A short-circuit-proof and protected against overload

### Note

- LED red: hard short-circuit, LED on permanently. The output cuts out and does not switch on again automatically. Reset by briefly interrupting the power supply/input voltage.
- Overload: LED pulsing, approx. 2 s on, approx. 30 s off. Device switches on again after removing the overload.
- Low load: LEDs on permanently, output is switched through.



C

Derating curve

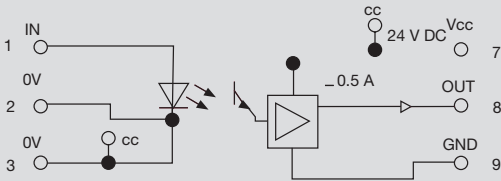
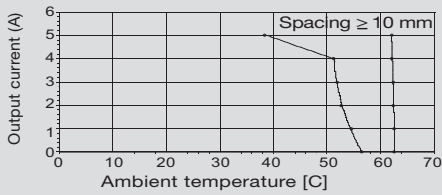

Output	
Output voltage	19.2 V DC ... 24 V DC ... 28.8 V DC
Output current (max.)	5 A
Voltage drop at max. load	
Block-state curr. (closed-circuit curr.)	
Switch-on delay/Switch-off delay	approx. 8 ms/25 ms
Short-circuit-proof/Protective circuit	Yes/max. 96 h/Varistor, polarity reversal protection
General data	
Operating temperature	-25 °C...+50 °C
Storage temperature	-40 °C...+85 °C
Approvals	CSA;cURus;CE;
Insulation coordination (EN 50 178)	
Standards	EN 50178
Rated voltage	300 V
Rated impulse withstand voltage	6.0 kV
Creepage and clearance path input - output	≥ 5.5 mm
Surge category	III
Pollution severity	2
Dimensions	
Clamping range (rating- / min. / max.)	mm <sup>2</sup> 1.5 / 0.5 / 2.5
Length x width x height	mm 92.4 / 22.5 / 112.4
Note	
Cross-connectors and markers - see WAVESERIES accessories	

### Ordering data

#### Input

Rated voltage  
Rated current  
Power rating  
Auxiliary voltage  
Status indicator

#### 24 V UC / 24 V DC 5 A

24 V UC ±10 %  
16.3 mA ac / 13.5 mA dc  
0.39 VA / 0.32 W  
no  
LED green in output

#### 115 V UC / 24 V DC 5 A

115 V UC, max. 130 V UC  
3.1 mA ac / 2.8 mA dc  
0.35 VA / 0.32 W  
no  
LED green in output

#### 230 V UC / 24 V DC 5 A

230 V UC, max. 250 V UC  
12 mA ac / 1.8 mA dc  
2.7 VA / 0.4W  
no  
LED green in output

#### Ordering data

##### Complete module

Screw connection Type  
Order No.  
Tension clamp connection Type  
Order No.

WOS2 24VUC  
**8275190000**

WOS2 115VUC  
**8296250000**

WOS2 230VUC  
**8275220000**

#### Ordering data

##### Spare relay, pluggable

Type  
Order No.

#### Note

Output voltage 230 V AC 3.5 A



Derating curve

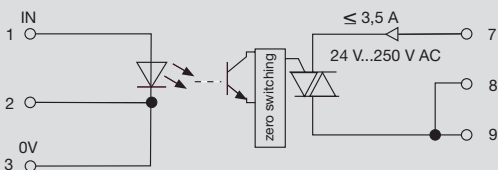
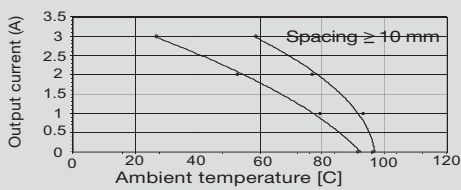

Output			
Output voltage	24 V AC ... 250 V AC		
Output current (max.)	3.5 A		
Voltage drop at max. load	1.6 V		
Block-state curr. (closed-circuit curr.)	2 mA		
Switch-on delay/Switch-off delay	max. 20 ms/max. 20 ms		
Short-circuit-proof/Protective circuit	no/RC combination with resistor		
General data			
Operating temperature	-25 °C...+50 °C		
Storage temperature	-40 °C...+85 °C		
Approvals	CSA;cURus;CE;		
Insulation coordination (EN 50 178)			
Standards	EN 50178		
Rated voltage	300 V		
Rated impulse withstand voltage	6.0 kV		
Creepage and clearance path input - output	≥ 5.5 mm		
Surge category	III		
Pollution severity	2		
Dimensions		Screw connection	Tension clamp connection
Clamping range (rating- / min. / max.)		mm <sup>2</sup>	1.5 / 0.5 / 2.5
Length x width x height		mm	92.4 / 22.5 / 112.4
Note		Cross-connectors and markers - see WAVESERIES accessories	

Ordering data

Input	15-60 V UC / 24 V DC 3.5 A	115 V UC / 230 V AC 3.5 A	230 V UC / 230 V AC 3.5 A	
Rated voltage	15 V UC...60 V AC/ 66 V DC	115 V UC, max. 130 V UC	230 V UC, max. 250 V UC	
Rated current	3,3...5,6 mA	3.8 mA ac / 7.2 mA dc	11.8 mA ac / 3.3 mA dc	
Power rating	0,31 VA / 0,33 W	0,44 VA / 0,82 W	2,7 VA / 0,75 W	
Auxiliary voltage	no	no	no	
Status indicator	LED green in output	LED green in output	LED green in output	

Ordering data

Complete module				
Screw connection	Type	WOS2 15-60VAC 66VDC	WOS2 115VUC	WOS2 230VUC
	Order No.	8275440000	8259950000	8275400000
Tension clamp connection	Type			
	Order No.			

Ordering data

Spare relay, pluggable				
	Type			
	Order No.			

Note				

**Optos - WAVESERIES**

for high switching frequency up to 100kHz



**C**

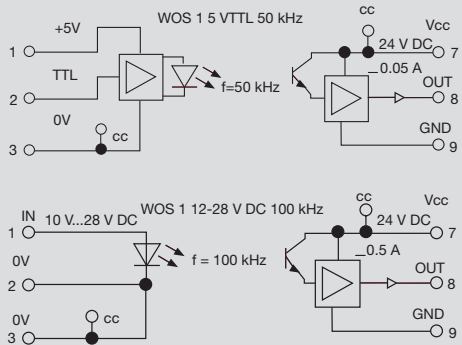
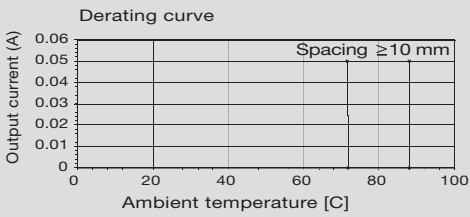

Output		
Output voltage	21.6 V DC ... 24 V DC ... 26.4 V DC	
Output current (max.)	50 mA	
Voltage drop at max. load		
Block-state curr. (closed-circuit curr.)		
Switch-on delay/Switch-off delay	1 µs/7 µs	
Short-circuit-proof/Protective circuit	no/Varistor, polarity reversal protection	
General data		
Operating temperature	-25°C...+60°C	
Storage temperature	-40 °C...+85 °C	
Approvals	CSA;cURus;CE;	
Insulation coordination (EN 50 178)		
Standards	EN 50178	
Rated voltage	300 V	
Rated impulse withstand voltage	6.0 kV	
Creepage and clearance path input - output	≥ 5.5 mm	
Surge category	III	
Pollution severity	2	
Dimensions	Screw connection	Tension clamp connection
Clamping range (rating- / min. / max.)	mm <sup>2</sup>	1.5 / 0.5 / 2.5
Length x width x height	mm	72 / 22.5 / 92.4
<b>Note</b>		Cross-connectors and markers - see WAVESERIES accessories

**Ordering data**

Input	5 V TTL 50 KHZ	12-28 V DC 100 KHZ		
Rated voltage	5 V TTL	12 V DC...28 V DC		
Rated current	13 mA	8 mA		
Power rating	65 mW	190 mW		
Auxiliary voltage	5 V	no		
Status indicator	LED green in output	LED green in output		

Ordering data				
<b>Complete module</b>				
Screw connection	Type	WOS1 5VTTL 50KHZ	WOS1 12-28VDC 100KHZ	
	Order No.	<b>8275210000</b>	<b>8275450000</b>	
Tension clamp connection	Type			
	Order No.			

Ordering data				
<b>Spare relay, pluggable</b>				
	Type			
	Order No.			

Note				



# Installation timer relays

Electronic time relays from the BT product range offer ideal solutions for industrial applications.

## The BT product range provides the following functions:

- Pick-up delay (BTR)
- Pulse emitter (BTTT)
- Multifunction (BTM)
- Multifunction (BTMF)
- Star-delta change-over

## Time ranges and power supplies for timer relays

Using the central knob, you can select the functions of the modules precisely over either 4 or 8 time ranges.

The multi-voltage supply voltage range offers a wide bandwidth for industrial use (see table).

### Time ranges

Display of time scale	Time ranges
0.1 s	0.1 to 1.2 s
1 s	1 to 12 s
0.1 min	0.1 to 1.2 min
1 min	1 to 12 min
0.1 h	0.1 to 1.2 h
1 h	1 to 12 h
10 h	10 to 120 h

Note:

If the rotary knob for time adjustment is set to “0”, the output will be switched without delay.

## Connection of the timer relay

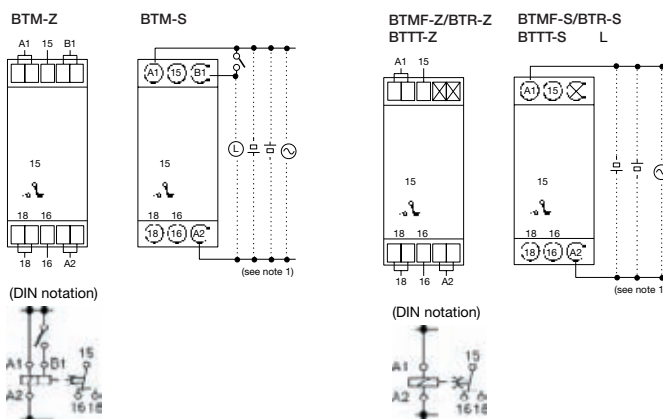

- Note:
1. Pole numbers are not necessary for DC voltage supply.
  2. The contact symbol of BTM is marked with  as it provides several operating modes and differs from the delayed contacts of conventional timer relays.

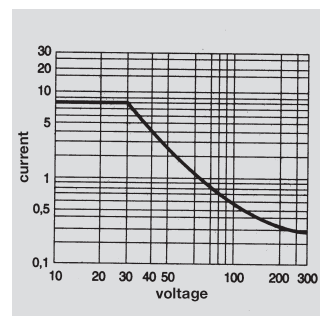
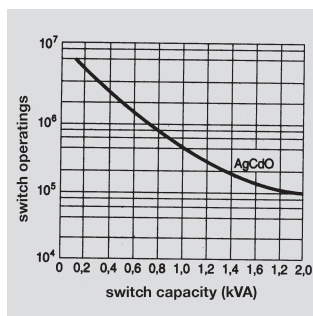

### Choosing the time range

The time range is chosen by turning the rotary switch for the ON-time scale and OFF-time scale. The time scales are visible in the display to the left of the rotary switch in the following order: 0.1 s, 1 s, 0.1 m, 1 m, 0.1 h, 1 h.

Note:

The time scales “1 s” and “0.1 h” are given twice. Both adjustments represent the same time scale.

### Locking/unlocking of selectors and time setting dial

The rotary switches for the ON/OFF time adjustment and the option selector for the time scale can be locked with the locking key.

This pen-style special tool is available separately. To lock either rotary switches or the option selector, simply insert the locking key into the keyhole bottom right of the rotary switch/option selector and turn it clockwise until the knob/switch is totally covered by the red cover. To unlock, simply turn the key in the opposite direction.

### Connection system

The units offers the following connection technologies:

Screw connection

- 2 x 1.5 mm<sup>2</sup> with wire end ferrule
- 2 x 2.5 mm<sup>2</sup> without wire end ferrule

Tension clamp connection

- 2 x 1.5 mm<sup>2</sup> with wire end ferrule
- 2 x 2.5 mm<sup>2</sup> without wire end ferrule

### Dimensions

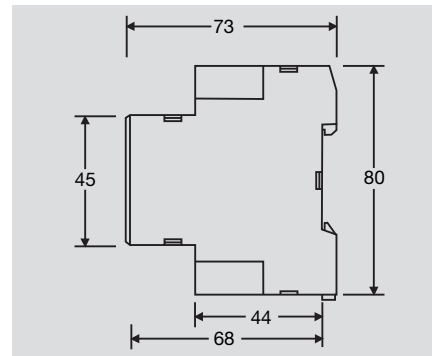

### Screw connection

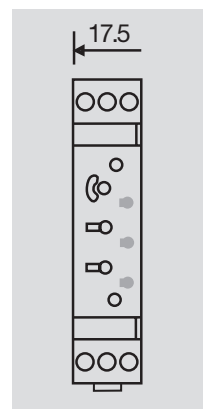

### Tension clamp connection

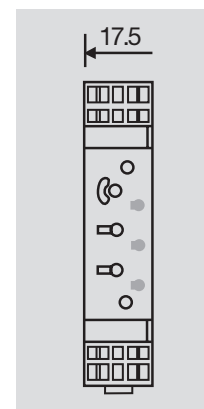

## Timer relays – BT-SERIES

### Installation timer relays

- Screw or tension clamp connection
- LED status indicator Input: voltage present  
Output: output active
- Approvals
 

<ul style="list-style-type: none"> <li>UL 508</li> <li>EN 61812-1</li> <li>IEC 60947-5-1</li> <li>IEC 60664-1</li> <li>EN 55011</li> </ul>	<ul style="list-style-type: none"> <li>CE 22.2 Nr. 14</li> <li>IEC 60664-1</li> <li>EN 61812-1</li> <li>IEC 60947-5-1</li> <li>EN 50082-2</li> </ul>
--------------------------------------------------------------------------------------------------------------------------------------------	------------------------------------------------------------------------------------------------------------------------------------------------------



#### Type designation:

- B** = Building
- T** = Timer
- R** = Response Delay
- TT** = Two Times
- M** = Multifunction, 8 ranges
- MF** = Multifunction, 4 ranges
- DS** = Delta, Star
- S** = Screw
- Z** = Tension

Input		Contacts hard gold plated	
Rated voltage		24 ... 230 V AC, 50/60 Hz, 24 ... 48 V DC	
Voltage tolerance		85 ... 100 % of rated voltage	
Breaking voltage		Max. 2.4 V AC/V DC	
Power consumption per type	V AC	21 ... 33 VA at 230 V	
	V DC	0.6 ... 1.3 W at 24 V	
Reset time		Min. 0.1 s (BTDS: 0.5 s)	
Insulation			
Insulation resistance		100 MΩ min, at 500 V DC	
Insulation test voltage			
	between input and output, to enclosure	2000 V AC, 50/60 Hz, 1 min	
	between non-adjacent contacts	1000 V AC, 50/60 Hz, 1 min	
Ingress protection class		IP30, terminal block IP20	
Output			
Contact/contact material		1 change-over contact (BTDS 2 NOC) / AgNi 90/10	
Switch output		5A at 250 V AC, resistive load (cos φ = 1)	
Service life	mechanical min.	10 <sup>7</sup> switching cycles (no load, 1800/h)	
	electrical min.	10 <sup>6</sup> switching cycles (5A at 250 V AC, resistive load at 1800/h)	
Time range		0.10 s ... 120 h	
Repetition accuracy		± 1 %	
Other data			
Flammability class as per UL 94		V-2	
Ambient temperature/storage temperature		-10 ... +55 °C / -25 ... +65 °C (without condensation)	
Clamping range (nominal/min/max)	mm <sup>2</sup>		
Length x width x height	mm	80.0 x 17.5 x 73.0	

### Accessories

Designation	Type	Qty.	Order No.
Locking and adjusting key	BT Lock Pen	1	8659840000

Multifunction relay with control input (BTM)

Ordering data

Connection system	Type	Qty	Order No.
Screw connection	BTM-S	1	8647700000
Tension clamp	BTM-Z	1	8647710000

Functions

Function A – on-delay

Connect power supply (A1/A2). When the input signal (B1/A2) is applied, the on-delay lasting for the set time T starts. The output R (15/18) connects the load at the end of the set time. To reset, the power supply has to be switched off.

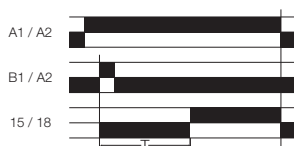

Function B – pulse emitter (starting at normal position)

Connect power supply (A1/A2). After applying the input signal (B1/A2), output R (15/18) switches the load synchronously and alternately between the normal and operated positions within the set time T. In this function, the cycle starts at the normal position.

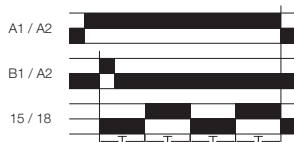

Function B2 – pulse emitter (starting at operated position)

Connect power supply (A1/A2). After applying the input signal (B1/A2), output R (15/18) switches the load synchronously and alternately between the normal and operated positions within the set time T. In this function, the cycle starts at the operated position.

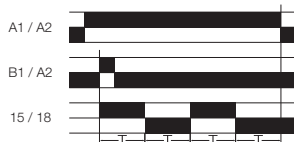

Function C – interval time-delay

Connect power supply (A1/A2). After applying the input signal (B1/A2), output R (15/18) connects the load for the set time T. Output R (15/18) switches the load off again at the end of time T.

After switching off the input signal (B1/A2), output R (15/18) connects the load again for the set time T. Output R (15/18) switches the load off again at the end of time T.



Function D – off-delay function

Connect power supply (A1/A2). After applying the input signal (B1/A2), output R (15/18) connects the load. The time delay T begins after the input signal (B1/A2) has been switched off. At the end of time T, output R (15/18) switches the load off again.

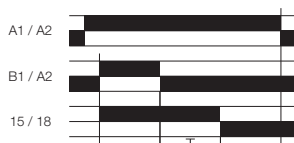

Function E – passing make function

Connect power supply (A1/A2). After applying the input signal (B1/A2), output R (15/18) connects the load immediately. At the end of the set delay time T, output R (15/18) switches the load off again.

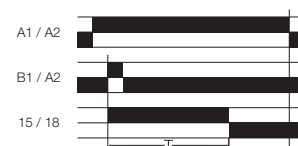

Function G – on and off-delay function

Connect power supply (A1/A2). Time delay T begins after applying the input signal (B1/A2). At the end of this time, output R (15/18) connects the load (on-delayed). After the input signal (B1/A2) has been switched off again, the output switches the load off again after the set time (off-delayed).

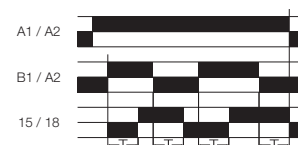

Function J – on-delay with pulse

Connect power supply (A1/A2). Time delay T begins after applying the input signal (B1/A2). At the end of this time, the output R (15/18) connects the load for 1 second.



## Timer relays – BT-SERIES

### Multi-function relay without control input (BTMF)

#### Ordering data

Connection system	Type	Qty	Order No.
Screw connection	BTMF-S	1	8647680000
Tension clamp	BTMF-Z	1	8647690000

### Timer relay (BTR)

#### Ordering data

Connection system	Type	Qty	Order No.
Screw connection	BTR-S	1	8647720000
Tension clamp	BTR-Z	1	8647730000

## C

### Functions

#### Function A – on-delay function

When the input signal (A1/A2) is applied, the on-delay lasting for the set time T starts. The output R (15/18) connects the load at the end of the set time. To reset, the power supply has to be switched off.

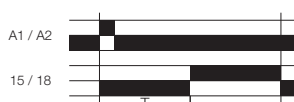

### Functions

#### Function A – on-delay

When the power supply is connected (A1/A2), the on-delay lasting for the set time T starts. The output R (15/18) connects the load at the end of the set time.



#### Function B2 – pulse emitter (starting at operated condition)

After applying the input signal (A1/A2), output R (15/18) switches the load synchronously and alternately between the normal and operated positions within the set time T. In this function, the cycle starts at the operated position.



#### Function E – passing make function

After applying the input signal (A1/A2), output R (15/18) connects the load immediately. At the end of the set delay time T, output R (15/18) switches the load off again.



#### Function J – on-delay with pulse

Time delay T begins after applying the input signal (A1/A2). At the end of this time, the output R (15/18) connects the load for 1 second.

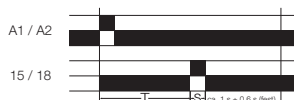

Timer relay (BTTT)

Timer relay (BTDS)

Ordering data

Connection system	Type	Qty	Order No.
Screw connection	BTTT-S	1	8647740000
Tension clamp	BTTT-Z	1	8647750000

Ordering data

Connection system	Type	Qty	Order No.
Screw connection	BTDS-S	1	8647660000
Tension clamp	BTDS-Z	1	8647670000

Functions

Function BTTT – pulse emitter

When the power supply is connected (A1/A2), the repeat cycle begins with two independently adjustable times. The standard setting is to start at the normal position. A bridge between connections A1 and A2 allows the module to start at the operated position.



Functions

Star-delta changeover

After connecting the power supply, output R1 (17/18) connects immediately. At the end of time T1, output R1 (17/18) switches off and time T2 starts. At the end of time T2, output R2 (27/28) connects. After switching off the power supply, output R2 (27/28) switches off.

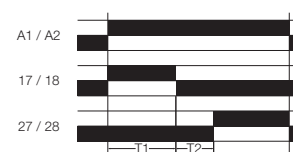

## Timer relay - DK-SERIES

### Mini-coupler DKZ

- Components for lengthening short pulses for the PLC
- Fixed switch-on/switch-off delay
- Low input power
- Screw clamp connection system
- Plug-in cross-connection
- 6 mm wide
- For mounting on TS 35

### 24 V DC 50 ms

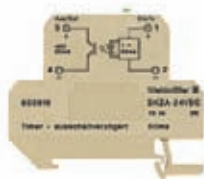

### 24 V DC 150 ms



### 24 V UC 1 s

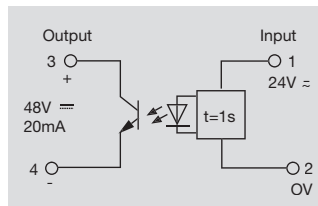
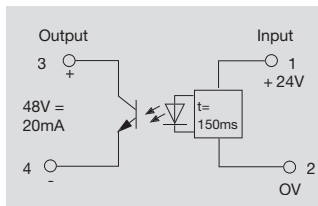
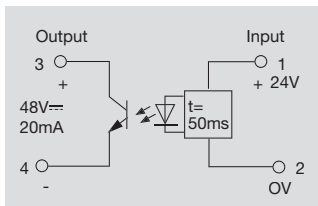

### Technical data

Input	24 V DC 50 ms	24 V DC 150 ms	24 V UC 1 s
Rated voltage	24 V DC ±18 %	24 V DC ±18 %	24 V UC ±10 %
Rated current DC	6.7mA	6.7 mA	5.1 mA
Rated current AC			6.1 mA
Power rating	160 mW	160 mW	130 mW / 150 mVA
Switch-on delay	50 ms	150 ms	1s
Switch-off delay	2.0	2.5	max. 0.7 ms
min. impulse duration			
Output			
max. switching voltage DC	48 V	48 V	48 V
max. switching current	20 mA	20 mA	20 mA
max. switching frequency at rated load	20.0 Hz	20.0 Hz	0.9 Hz
Rated data			
Operating temperature	-25 °C...+50 °C	-25 °C...+50 °C	-25 °C...+50 °C
Storage temperature	-40 °C...+85 °C	-40 °C...+85 °C	-40 °C...+85 °C
Insulation coordination (EN 50178)			
Rated voltage	300 V	300 V	300 V
Impulse withstand voltage	4 kV	4 kV	4 kV
Surge category	III	III	III
Pollution severity	2	2	2
Creepage and clearance path input - output	≥ 4 mm	≥ 4 mm	≥ 4 mm
Dielectric strength, Input/Output	4 kV	4 kV	4 kV

Dimensions	Screw connection	Screw connection	Screw connection
Clamping range (rating- / min. / max.)	4 / 0.5 / 4	4 / 0.5 / 4	4 / 0.5 / 4
Length x width x height	65 x 6 x 62	65 x 6 x 62	65 x 6 x 62
Note	for mounting on rail TS 35	for mounting on rail TS 35	for mounting on rail TS 35

### Ordering data

Connection system	Type	(Qty.=1)	Order No.	Type	(Qty.=1)	Order No.	Type	(Qty.=1)	Order No.
Screw connection	DKZA 35 24VDC 50MS		8008180000	DKZA 35 24VDC 150MS		8022110000	DKZ 35 24VUC 1S		8008190000
<b>Note</b>									

### Accessories

Note	End plate	End plate	End plate
	AP DK4 0687560000	AP DK4 0687560000	AP DK4 0687560000

**Mini-coupler DKZ**

- Components for lengthening short pulses for the PLC
- Fixed switch-on/switch-off delay
- Low input power
- Screw clamp connection system
- Plug-in cross-connection
- 6 mm wide
- For mounting on TS 35

**24 V DC 10-100 ms**

**24 V DC 0.1-1 s**

**24 V DC 1-100 s**

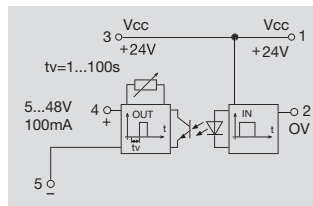
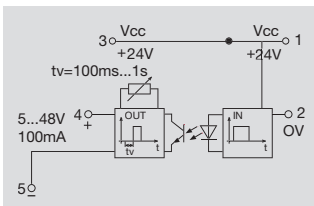
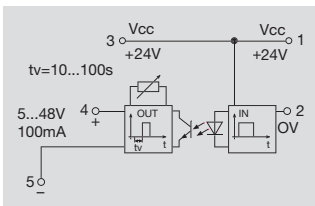
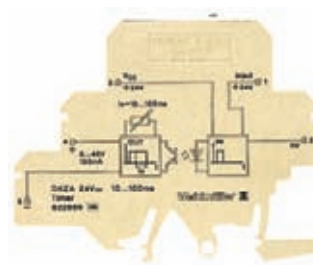
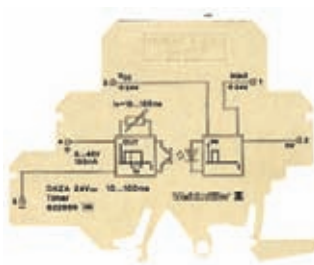
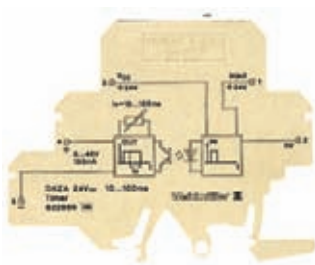

**Technical data**

**Input**

Rated voltage	24 V DC ±20 %
Rated current DC	approx. 12 mA
Power rating	290 mW
Switch-on delay	10...100 ms (adjustable)

**Output**

max. switching voltage DC	48 V
max. switching current	100 mA

**Rated data**

Operating temperature	-25 °C...+50 °C
Storage temperature	-40 °C...+85 °C

**Insulation coordination (EN 50178)**

Rated voltage	300 V
Impulse withstand voltage	6 kV
Surge category	IV
Pollution severity	2
Creepage and clearance path input - output	≥ 5.5 mm
Dielectric strength, Input/Output	4 kV

Rated voltage	24 V DC ±20 %
Rated current DC	approx. 12 mA
Power rating	290 mW
Switch-on delay	100 ms ... 1 s (adjustable)
max. switching voltage DC	48 V
max. switching current	100 mA
Operating temperature	-25 °C...+50 °C
Storage temperature	-40 °C...+85 °C
Rated voltage	300 V
Impulse withstand voltage	6 kV
Surge category	IV
Pollution severity	2
Creepage and clearance path input - output	≥ 5.5 mm
Dielectric strength, Input/Output	4 kV

Rated voltage	24 V DC ±20 %
Rated current DC	approx. 12 mA
Power rating	290 mW
Switch-on delay	100 ms ... 1 s (adjustable)
max. switching voltage DC	48 V
max. switching current	100 mA
Operating temperature	-25 °C...+50 °C
Storage temperature	-40 °C...+85 °C
Rated voltage	300 V
Impulse withstand voltage	6 kV
Surge category	IV
Pollution severity	2
Creepage and clearance path input - output	≥ 5.5 mm
Dielectric strength, Input/Output	4 kV

Rated voltage	24 V DC ±20 %
Rated current DC	approx. 12 mA
Power rating	290 mW
Switch-on delay	1 ... 100 s (adjustable)
max. switching voltage DC	48 V
max. switching current	100 mA
Operating temperature	-25 °C...+50 °C
Storage temperature	-40 °C...+85 °C
Rated voltage	300 V
Impulse withstand voltage	6 kV
Surge category	IV
Pollution severity	2
Creepage and clearance path input - output	≥ 5.5 mm
Dielectric strength, Input/Output	4 kV

**Dimensions**

Clamping range (rating- / min. / max.)	mm <sup>2</sup>
Length x width x height	mm

**Note**

**Screw connection**

4 / 0.5 / 4
77 x 6 x 62

for mounting on rail  
TS 32/35

**Screw connection**

4 / 0.5 / 4
77 x 6 x 62

for mounting on rail  
TS 32/35

**Screw connection**

4 / 0.5 / 4
77 x 6 x 62

for mounting on rail  
TS 32/35

**Ordering data**

**Connection system**

Screw connection

Type	(Qty.=1)	Order No.
DKZ DK5 24VDC 10-100MS		8228680000

Type	(Qty.=1)	Order No.
DKZ DK5 24VDC 0.1-1S		8243780000

Type	(Qty.=1)	Order No.
DKZ DK5 24VDC 1-100S		8019650000

**Note**

**Accessories**

**Note**

End plate AP DK5 8268870000
--------------------------------

End plate AP DK5 8268870000
--------------------------------

End plate AP DK5 8268870000
--------------------------------

## Timer relay - DK-SERIES

### Mini-coupler DKZ

- Components for lengthening short pulses for the PLC
- Fixed switch-on/switch-off delay
- Low input power
- Screw clamp connection system
- Plug-in cross-connection
- 6 mm wide
- For mounting on TS 35

### 24 V DC 10-100 ms

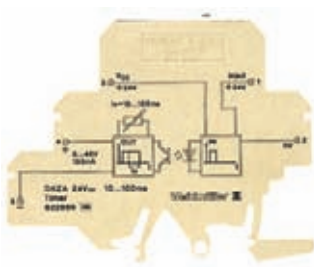

### 24 V DC 0.1-1 s

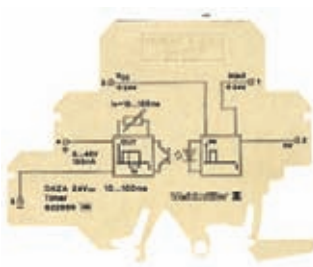

### 24 V DC 1-100 s

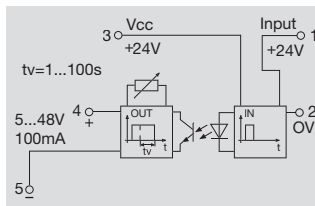
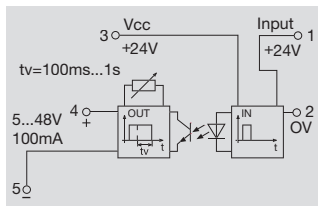
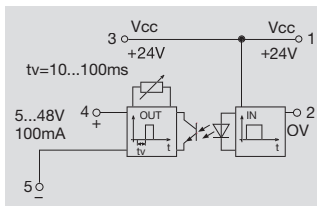
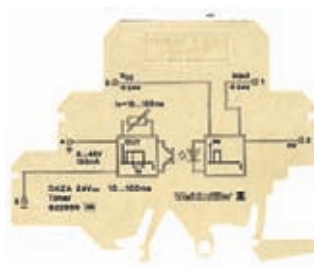

### Technical data

Input	24 V DC 10-100 ms	24 V DC 0.1-1 s	24 V DC 1-100 s
Rated voltage	24 V DC ±20 %	24 V DC ±20 %	24 V DC ±20 %
Rated current DC	approx. 11 mA	approx. 11 mA	approx. 11 mA
Power rating		260 mW	
Switch-off delay	10 ... 100 ms (adjustable)	100 ms ... 1 s (adjustable)	1 ... 100 s (adjustable)
Output			
max. switching voltage DC	48 V	48 V	48 V
max. switching current	100 mA	100 mA	100 mA
Rated data			
Operating temperature	-25 °C...+50 °C	-25 °C...+50 °C	-25 °C...+50 °C
Storage temperature	-40 °C...+85 °C	-40 °C...+85 °C	-40 °C...+85 °C
Insulation coordination (EN 50178)			
Rated voltage	300 V	300 V	300 V
Impulse withstand voltage	6 kV	6 kV	6 kV
Surge category	IV	IV	IV
Pollution severity	2	2	2
Creepage and clearance path input - output	≥ 5.5 mm	≥ 5.5 mm	≥ 5.5 mm
Dielectric strength, Input/Output	4 kV	4 kV	4 kV

### Dimensions

Clamping range (rating- / min. / max.) mm<sup>2</sup>  
 Length x width x height mm

### Screw connection

4 / 0.5 / 4  
 77 x 6 x 62

### Screw connection

4 / 0.5 / 4  
 77 x 6 x 62

### Screw connection

4 / 0.5 / 4  
 77 x 6 x 62

### Note

for mounting on rail  
 TS 32/35

for mounting on rail  
 TS 32/35

for mounting on rail  
 TS 32/35

### Ordering data

Connection system	Type	(Qty.=1)	Order No.	Type	(Qty.=1)	Order No.	Type	(Qty.=1)	Order No.
Screw connection	DKZA DK5 24VDC 10-100MS		8228690000	DKZA DK5 24VDC 0.1-1S		8243770000	DKZA DK5 24VDC 1-100S		8019630000
Note									

### Accessories

Note	End plate	AP DK5	8268870000	End plate	AP DK5	8268870000	End plate	AP DK5	8268870000

**Miniconditioner MCZ TO**

- Components for lengthening short pulses for the PLC
- Fixed switch-off delay
- Low input power
- Tension clamp connection system
- Plug-in cross-connection
- 6 mm wide
- For mounting on TS 35

**24 V DC 50 ms**

**24 V DC 150 ms**

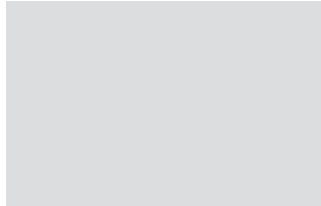
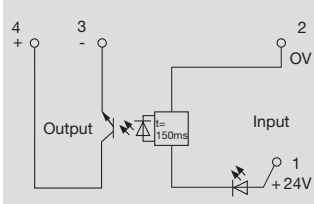
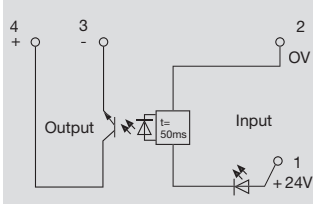

**Technical data**

**Input**

Rated voltage  
Rated current DC  
Power rating  
Switch-off delay  
min. impulse duration

24 V DC  $\pm 10\%$   
6.7mA  $\pm 10\%$   
160 mW  
50 ms  
2.0 ms

24 V DC  $\pm 10\%$   
6.7mA  $\pm 10\%$   
160 mW  
150 ms  
2.5 ms

**Output**

max. switching voltage DC  
max. switching current  
max. switching frequency at rated load

48 V  
20 mA  
20.0 Hz

48 V  
20 mA  
5.0 Hz

**Rated data**

Operating temperature  
Storage temperature

-25 °C...+50 °C  
-40 °C...+85 °C

-25 °C...+50 °C  
-40 °C...+85 °C

**Insulation coordination (EN 50178)**

Rated voltage  
Impulse withstand voltage  
Surge category  
Pollution severity  
Creepage and clearance path input - output  
Dielectric strength, Input/Output

300 V  
6 kV  
III  
2  
 $\geq 5.5$  mm  
4 kV

300 V  
6 kV  
III  
2  
 $\geq 5.5$  mm  
4 kV

**Dimensions**

Clamping range (rating- / min. / max.) mm<sup>2</sup>  
Length x width x height mm

**Tension clamp c.**

1.5 / 0.5 / 2.5  
91 x 6 x 63.2

**Tension clamp c.**

1.5 / 0.5 / 2.5  
91 x 6 x 63.2

**Note**

for mounting on TS 35

for mounting on TS 35

**Ordering data**

**Connection system**

Tension clamp connection

Type	(Qty.=1)	Order No.
MCZ TO 24VDC/50MS		8324590000

Type	(Qty.=1)	Order No.
MCZ TO 24VDC/150MS		8286410000

**Note**

**Accessories**

**Note**

End plate  
AP MCZ 8389030000

End plate  
AP MCZ 8389030000

# Overview of function components

## Switch and button modules

The dimensions of the switch and button modules are adapted to suit the electronic components in the integral housing.

The housings are equipped with a universal DIN rail mounting foot for TS 32 and TS 35 terminal rails.

Buttons and switches simplify the commissioning, maintenance, monitoring and repair of systems. The contacts are rated for inductive or resistive load.

When switching inductive loads, a contact protection circuit has to be provided, such as Weidmüller terminals with diodes or RC combination.

## Fuse modules

Unlike fuse terminals with a failure indicator, here an LED indicates that the fuse is functional. The circuit carries no closed-circuit current when the fuse is defective.

Example of use:  
Fuse for a solenoid valve

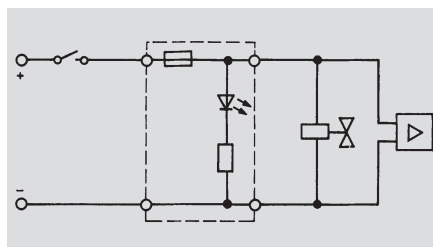

If the fuse is defective, no data is sent to the electronic component.

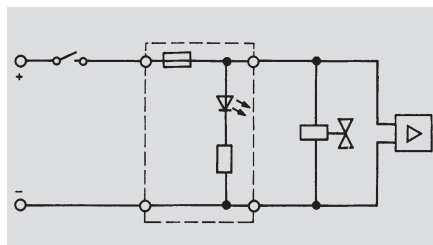

The electronic component receives – via the current of the LED – incorrect data about the switching state of the solenoid valve.

## Rectifier circuit

EGD rectifier modules are accommodated in EG2 housings which clip onto the mounting rail.

The bridge circuit consists of 4 individual diodes which allow for an extended input voltage range of 5 to 240 V AC

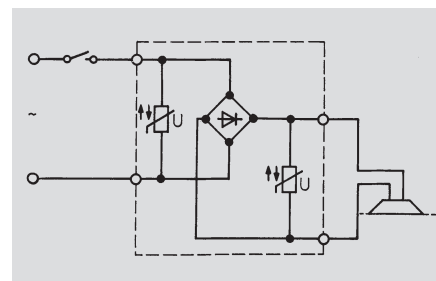

The DC output voltage is 90 % of the AC input voltage; a load capacitor is not used. Varistors in both the input and output circuits protect the industry-grade rectifier circuits from dangerous surge.

Input voltage

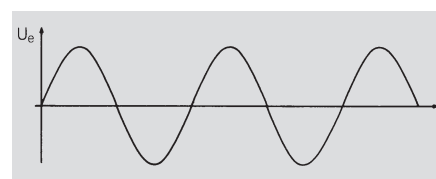

Output voltage

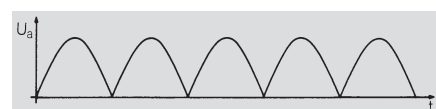

**EGT 1**

Switch and button module



**EGS**

Fuse module with indicator

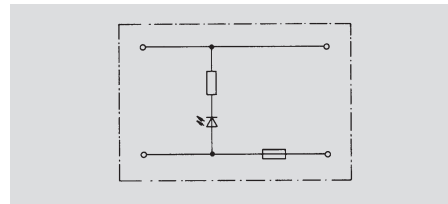

**Technical data**

Nominal data	
Input voltage	
Rated current	

Max. 250 V~		
	EGT 0	EGT 1 to EGT 6
Resistive load	3 A/250 V~	6 A/250 V~
Inductive load	5 A/30 V~	4 A/250 V~

230 V~ or 24 V~ or 42 V~	
Max. 6.3 A	
5 x 20 mm fuse	

Storage temperature	-40 °C ... +100 °C
Ambient temperature	
- fitted without spacing on rail	-25 °C ... +8 °C
- fitted with 20 mm spacing on rail	-25 °C ... +85 °C
<b>Insulation coordination as per EN 50178</b>	
Surge category	
Pollution severity	

-40 °C ... +100 °C	
-25 °C ... +8 °C	
-25 °C ... +85 °C	

-40 °C ... +100 °C	
-25 °C ... +55 °C	
-25 °C ... +65 °C	
1	
2	

**Ordering data**

Type	Switching function	Qty	Order No.
EGT 0	1 NCC 1 NOC	10	8002290000
EGT 1	Circuit-breaker	10	0126360000
EGT 2	Change-over contact, switching	10	0104060000
EGT 4	Change-over contact, off position in the middle, button to one side, switching to one side	10	0104360000
EGT 5	Change-over contact, off position in the middle, button to both sides	10	0104260000
EGT 6	Change-over contact, button	10	0114660000

Type	Qty	Order No.
EGS 230 V~	10	1115860000
EGS 24 V~	10	0193860000

Type	Qty	Order No.
EGS 230 V~	10	1115860000
EGS 24 V~	10	0193860000

Function components

C

EGD 1

Rectifier circuit

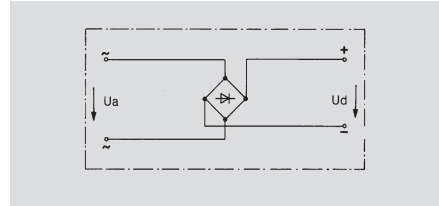

EGD 2

Rectifier circuit with varistor protection circuit

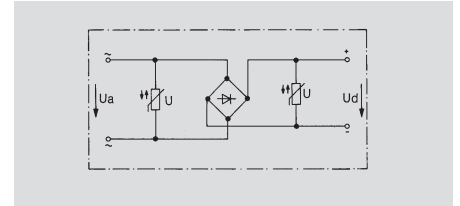

Technical data

Nominal data

Input voltage  
Rated current

5 V~ ... 240 V~, 50 ... 60 Hz  
1 A

5 V~ ... 240 V~, 50 ... 60 Hz  
1 A

Derating curve

a = fitted without spacing on mounting rail  
b = fitted at 20 mm spacing on mounting rail

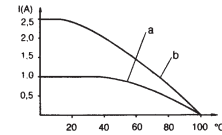
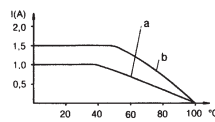
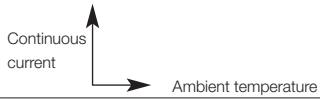

Max. downstream load capacitor

200 µF

500 µF

Current load max.

1.5A (see derating curve)

2.5 A (see derating curve)

Surge current limit value

40 A (10 ms)

10 A (10 ms)

Conducting-state voltage

≤ 2 V

≤ 2.2 V

Output voltage

$U_d = 0,9 \times U_a$

$U_d = 0,9 \times U_a$

Storage temperature

-45 °C ... +100 °C

-45 °C ... +100 °C

Ambient temperature

- fitted without spacing on mounting rail

-30 °C ... +40 °C

-30 °C ... +40 °C

- fitted at 20 mm spacing on mounting rail

-30 °C ... +70 °C

-30 °C ... +70 °C

Insulation coordination as per EN 50178

Surge category

II

II

Pollution severity

2

2

Ordering data

Type	Qty	Order No.
EGD 1	10	0546160000

Type	Qty	Order No.
EGD 2	10	0546260000

Inputs and outputs

Amplified DKV

DKV 5 V DC

DKV 24 V DC

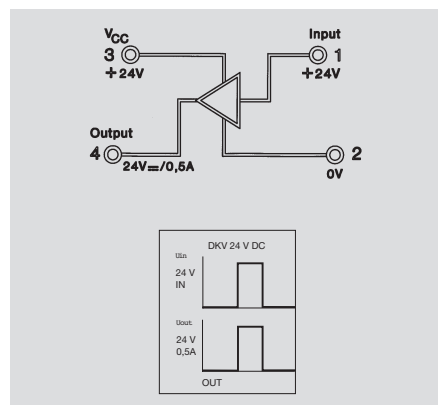
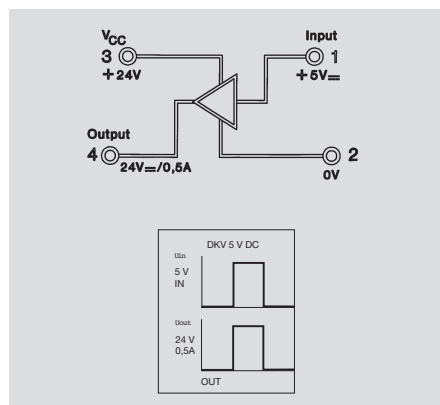
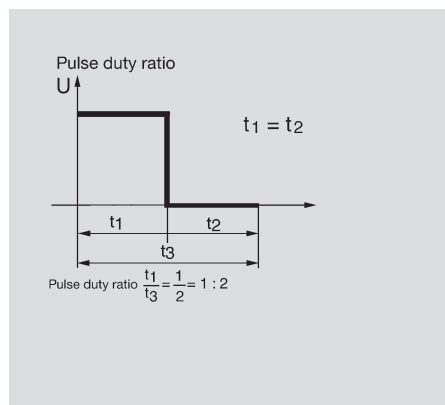
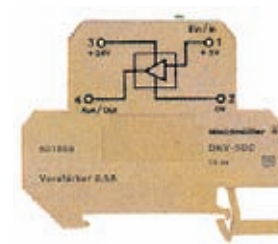
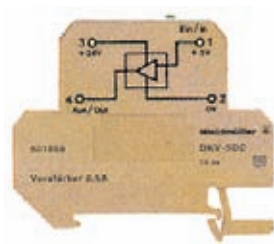

Technical data

Input voltage	
Switching threshold	
Input current	
Power loss, max.	
Output voltage	
Output current, max.	
Output current, min.	
Switching frequency, max.; duty factor 1:2	
Voltage drop at max. load	
Block-state current	
<b>Insulation coordination as per EN 50178</b>	
Operating temperature	without spacing
	with spacing
Storage temperature	
Conductor	
Conductor cross-section	
Width	

5 V DC ± 10 %	
off: ≤ 1.5 V on: ≥ 4.5 V	
approx. 3 V	
100 µA	
500 µW	
24 V DC	
500 mA	
50 µA	
3 kHz	
≤ 450 mV	
≤ 20 µA	
no galvanic isolation between input and output	
-25 °C ... +40 °C	
-25 °C ... +50 °C	
-40 °C ... +85 °C	
AWG 22 ... 12	
0.5 ... 4 mm <sup>2</sup>	
6 mm	

24 V DC ± 10 %	
off: ≤ 6 V on: ≥ 20.4 V	
approx. 13 V	
5 mA	
550 mW	
24 V DC	
500 mA	
50 µA	
3 kHz	
≤ 900 mV	
≥ 50 µA	
no galvanic isolation between input and output	
-25 °C ... +40 °C	
-25 °C ... +50 °C	
-25 °C ... +85 °C	
AWG 22 ... 12	
0.5 ... 4 mm <sup>2</sup>	
6 mm	

Ordering data

for TS 35	

Type	Order No.
DKV 5 V DC	8018590000
input at bottom	

Type	Order No.
DKV 24 V DC	8015790000
input at bottom	

Accessories

End plate	

Type	Order No.
AP DKT4	0687560000

Type	Order No.
AP DKT4	0687560000

Function components

Inputs and outputs

Inverter

DKLI 24 V DC

DKPI 24 V DC

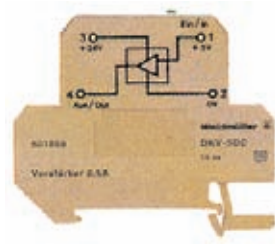

C

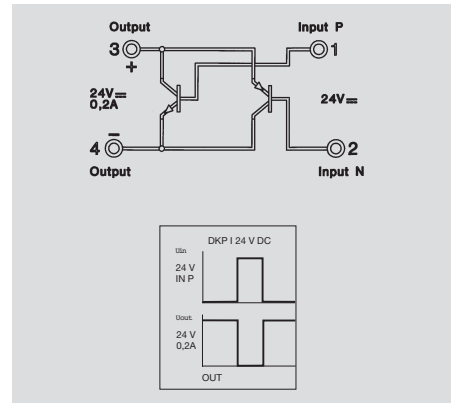
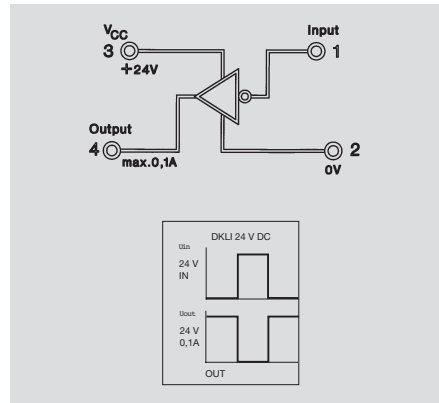
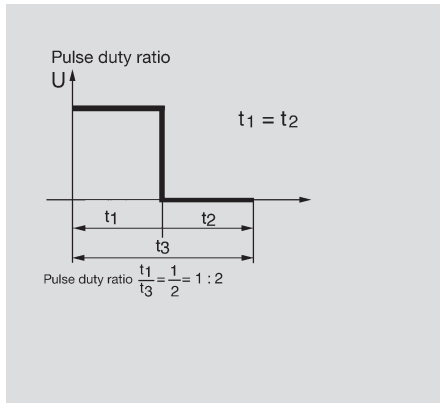

Technical data

Input voltage	24 V DC ± 10 % off: ≥ 20.4 V on: ≤ 4 V	P: 24 V DC ± 10 % N: -2.4...+2.4 V DC
Switching threshold	approx. 8 V	P: approx. 18 V / N: approx. 8 V
Input current	7,5 mA	approx. 8 mA
Power loss, max.	230 mW	approx. 500 mW
Output voltage	24 V DC locked	24 V DC
Output current, max.	100 mA 0 mA	200 mA
Output current, min.	50 µA	50 µA
Switching frequency, max.; duty factor 1:2	3 kHz	3 kHz
Voltage drop at max. load	100 mV	≤ 1,5 V
Block-state current	≤ 50 µA	≤ 50 µA
<b>Insulation coordination as per EN 50178</b>		
Operating temperature	no isolation between input and output -25 °C ... +40 °C -25 °C ... +50 °C	no isolation between input and output -25 °C ... +40 °C -25 °C ... +50 °C
Storage temperature	-40 °C ... +85 °C	-25 °C ... +85 °C
Conductor	AWG 22 ... 12	AWG 22 ... 12
Conductor cross-section	0.5 ... 4 mm <sup>2</sup>	0.5 ... 4 mm <sup>2</sup>
Width	6 mm	6 mm

Ordering data

for TS 35	<b>Type</b> DKLI 24 V DC	<b>Order No.</b> 8010950000	<b>Type</b> DKPI 24 V DC	<b>Order No.</b> 8019530000
	input at bottom		input at bottom	

Accessories

End plate	<b>Type</b> AP DKT4	<b>Order No.</b> 0687560000	<b>Type</b> AP DKT4	<b>Order No.</b> 0687560000
-----------	------------------------	--------------------------------	------------------------	--------------------------------