

FFH6 S1/26V F1 B RL

Weidmüller Interface GmbH & Co. KG

Klingenbergstraße 26

D-32758 Detmold

Germany

www.weidmueller.com

Product image

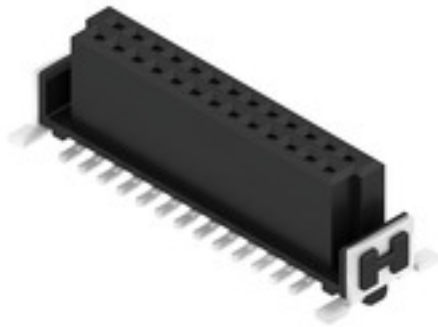

OMNIMATE® - Board-to-Board connectors

Flexible engineering of compact devices

The use of future-proof contact systems, as well as the optimisation of manufacturing processes, are increasingly important in the development of efficient industrial devices, especially in the field of Industry 4.0.

OMNIMATE® board-to-board connectors feature a 1.27 mm pitch and offer maximum flexibility due to different designs.

- **Flexible device design** - Industrial suitable density combined with high flexible connection combinations (Mezzanine, Mother-to-Daughter, Extender-card, Cable-to-Board)
- **Automation-Ready** - Developed for automatic assembly with high precise pin coplanarity and SMT-fixation
- **Reliable contact** - Up to 500 mating cycles due to industry suitable gold-surface (PdNi-Au)
- **Process-Ready** - High performance LCP material for reflow soldering
- **Scalability** - Different heights with high contact overlapping ensure various solutions from 12 – 80 poles.
- **Robust miniaturisation** - simple and safe connection even possible under unfavorable mating conditions – e.g. inclination or offset.

General ordering data

Version	PCB plug-in connector, female header, SMD solder connection, Pitch in mm (P): 1.27 mm, Number of poles: 26, 180°, Tape
Order No.	2747280000
Type	FFH6 S1/26V F1 B RL
GTIN (EAN)	4064675000921
Qty.	280 pc(s).
Product data	IEC: / 2.8 A UL: 150 V
Packaging	Tape

FFH6 S1/26V F1 B RL

Weidmüller Interface GmbH & Co. KG

Klingenbergstraße 26

D-32758 Detmold

Germany

www.weidmueller.com

Technical data

Dimensions and weights

Depth	7.8 mm	Depth (inches)	0.307 inch
Height	7.1 mm	Height (inches)	0.28 inch
Width	21.59 mm	Width (inches)	0.85 inch
Net weight	2.58 g		

System specifications

Transmission rate	3.125 Gbit/s	Product family	OMNIMATE Signal - Board-to-Board
Type of connection	Board connection	Mounting onto the PCB	SMD solder connection
Pitch in mm (P)	1.27 mm	Pitch in inches (P)	0.05 inch
Outgoing elbow	180°	Number of poles	26
Number of solder pins per pole	1	Coplanarity:	0.1 mm
Number of rows	1	Pin series quantity	2
Protection degree	IP20	Volume resistance	<25 mΩ
Plugging cycles	500	Plugging force/pole, max.	0.6 N
Pulling force/pole, max.	0.6 N		

Material data

Insulating material	LCP	Colour	black
Colour chart (similar)	RAL 9011	Insulating material group	Illa
Insulation strength	≥ 10 ¹⁰ Ω	Moisture Level (MSL)	1
UL 94 flammability rating	V-0	Contact base material	Cu-alloy
Contact material	Cu-alloy	Contact surface	Gold over nickel
Layer structure of plug contact	≥ 2 μm Ni / ≥ 0.4 μm PdNi / ≥ 0.05 μm Au	Storage temperature, min.	-40 °C
Storage temperature, max.	70 °C	Operating temperature, min.	-55 °C
Operating temperature, max.	125 °C		

Rated data acc. to IEC

Rated current, min. number of poles (Tu=20°C)	2.8 A	Clearance, min.	0.4 mm
Creepage distance, min.	0.4 mm		

Rated data acc. to UL 1977

Reference to approval values	Specifications are maximum values, details - see approval certificate.	Rated voltage (UL 1977) (obsolete)	150 V
------------------------------	--	------------------------------------	-------

Packing

Packaging	Tape	VPE length	359 mm
VPE width	352 mm	VPE height	152 mm

Classifications

ETIM 6.0	EC002637	ETIM 7.0	EC002637
ETIM 8.0	EC002637	ETIM 9.0	EC002637
ECLASS 9.0	27-44-04-02	ECLASS 9.1	27-44-04-02
ECLASS 10.0	27-44-04-02	ECLASS 11.0	27-46-02-01
ECLASS 12.0	27-46-02-01	ECLASS 13.0	27460201

FFH6 S1/26V F1 B RL

Weidmüller Interface GmbH & Co. KG
 Klingenbergstraße 26
 D-32758 Detmold
 Germany

www.weidmueller.com

Drawings

Product image

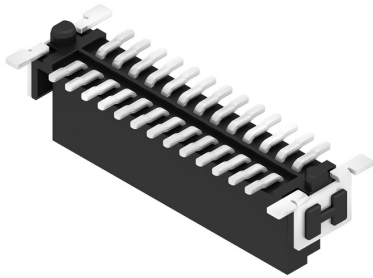

Dimensional drawing

Type	Order no.	No. of poles	A	B	C	D	E	G
FFH6 S1/26V F1 B RL	2747290000	12	8,96	10,77	12,7	8,37	8,77	2,48
FFH6 S1/16V F1 B RL	2747290000	16	8,89	13,31	15,24	11,91	10,91	3,73
FFH6 S1/20V F1 B RL	2747320000	20	11,43	15,68	17,78	14,40	13,68	5
FFH6 S1/26V F1 B RL	2747290000	26	15,24	19,60	21,98	18,26	17,26	7,54
FFH6 S1/20V F1 B RL	2747290000	32	18,5	23,47	26,4	22,07	21,07	8,81
FFH6 S1/40V F1 B RL	2747320000	40	24,13	29,55	30,48	27,15	26,15	11,95
FFH6 S1/50V F1 B RL	2747320000	50	30,48	34,29	38,83	33,5	32,5	15,16
FFH6 S1/60V F1 B RL	2747320000	60	41,91	46,33	48,26	44,93	43,93	20,24
FFH6 S1/80V F1 B RL	2747320000	80	48,26	53,66	55,98	52,65	51,65	24,65

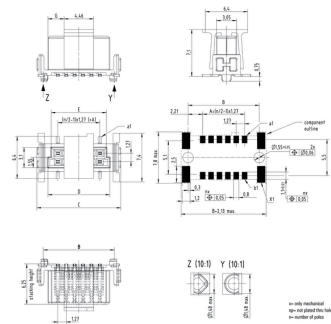

Detailed drawing

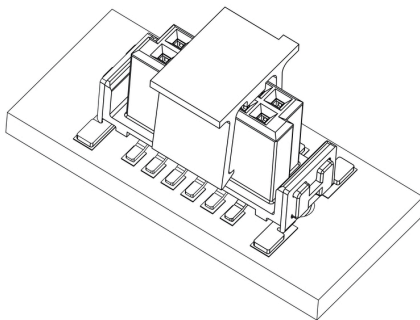

Derating curve

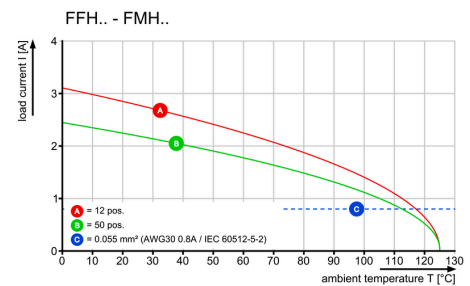

FFH6 S1/26V F1 B RL

Weidmüller Interface GmbH & Co. KG
Klingenbergstraße 26
D-32758 Detmold
Germany

www.weidmueller.com

Drawings

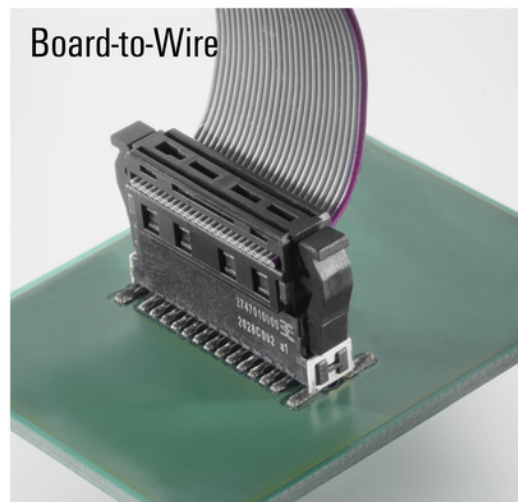
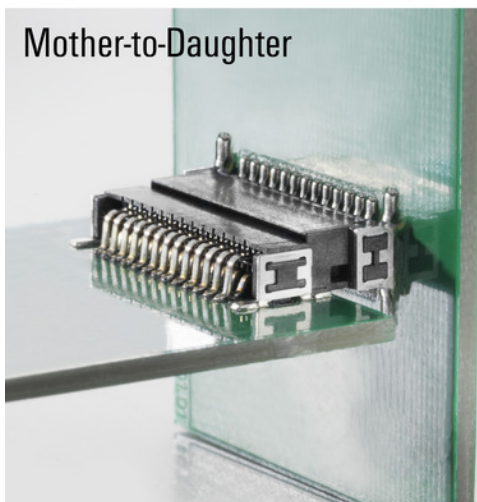
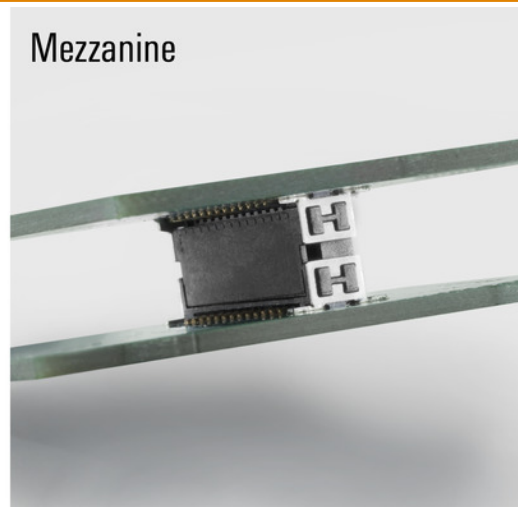
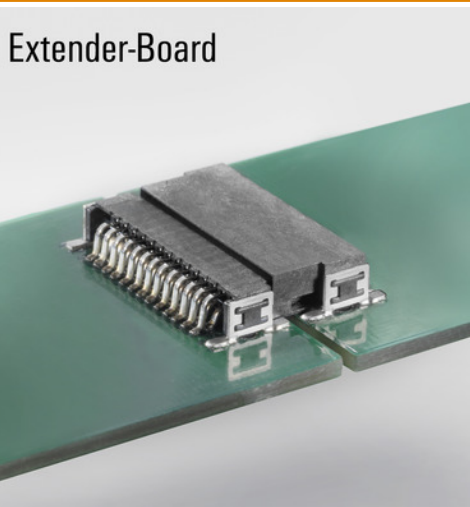

FFH6 S1/..V F1 B RL

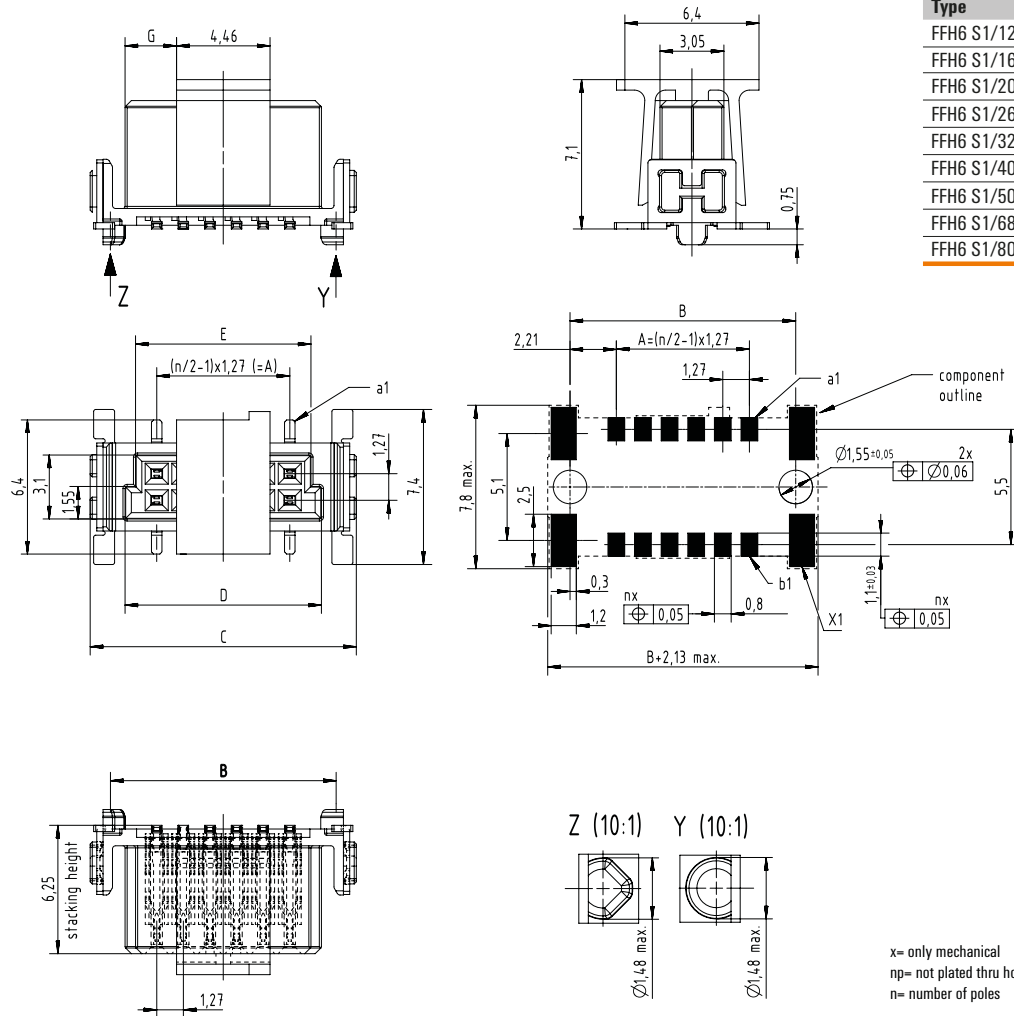

Type	Order no.	No. of poles	A	B	C	D	E	G
FFH6 S1/12V F1 B RL	2747250000	12	6,35	10,77	12,7	9,37	8,37	2,46
FFH6 S1/16V F1 B RL	2747260000	16	8,89	13,31	15,24	11,91	10,91	3,73
FFH6 S1/20V F1 B RL	2747270000	20	11,43	15,85	17,78	14,45	13,45	5
FFH6 S1/26V F1 B RL	2747280000	26	15,24	19,66	21,59	18,26	17,26	7,54
FFH6 S1/32V F1 B RL	2747290000	32	19,5	23,47	25,4	22,07	21,07	8,81
FFH6 S1/40V F1 B RL	2747300000	40	24,13	28,55	30,48	27,15	26,15	11,35
FFH6 S1/50V F1 B RL	2747310000	50	30,48	34,29	36,83	33,5	32,5	15,16
FFH6 S1/68V F1 B RL	2747320000	68	41,91	46,33	48,26	44,93	43,93	20,24
FFH6 S1/80V F1 B RL	2747330000	80	49,53	53,95	55,88	52,55	51,55	24,05

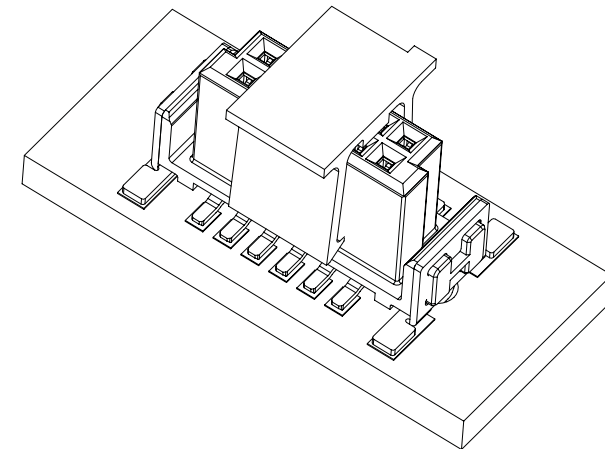

x= only mechanical
 np= not plated thru hole
 n= number of poles

Female vertical - FFH6 | FFH9

Application - dimensions

	14 mm				
	13 mm				
	12 mm				
	11 mm				
	10 mm				
	9 mm				
	8 mm				
X	stacking	male 1,75mm	male 3,25mm	male 1,75mm	male 3,25mm
Y	heights	female 6,25mm	female 6,25mm	female 9,05mm	female 9,05mm
S	PCB distance	8mm - 9,5mm	9,5mm - 11mm	10,8mm - 12,3mm	12,3mm - 13,8mm
	Type	FMH1.. FFH6..	FMH3.. FFH6..	FMH1.. FFH9..	FMH3.. FFH9..

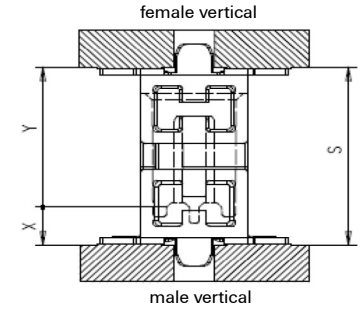
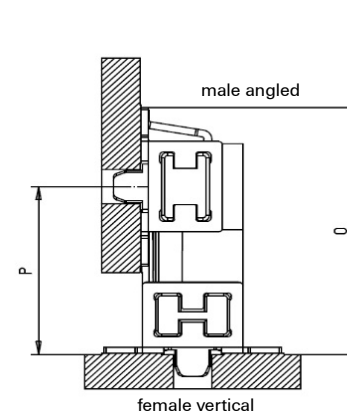

X	Y	S min.	*S max.	P min.	O
3,25	9,05	12,3	13,8	-	-
1,75	9,05	10,8	12,3	-	-
3,25	6,25	9,5	11	-	-
1,75	6,25	8	9,5	-	-
-	9,05	-	-	10,5	14,33
-	6,25	-	-	7,7	11,53

*S max. = S min. + 1,15 wiping length with additional contact overlap security

Mating conditions

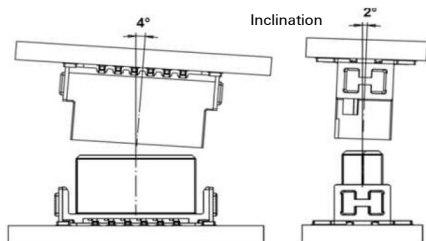
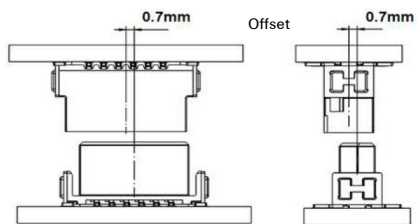

Tape - dimensions

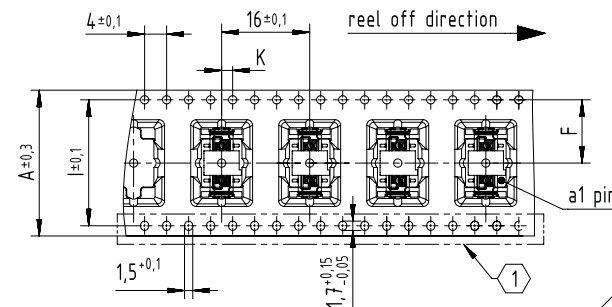

Tape dimensions	A	F	I	K
Pole 12	24,0	11,5 ± 0,1	-	2 ± 0,1
Poles 14 to 20	32,0	14,2 ± 0,1	28,4	2 ± 0,1
Poles 22 to 40	44,0	20,2 ± 0,15	40,2	2 ± 0,15
Poles 42 to 56	56,0	26,2 ± 0,15	52,4	2 ± 0,15
Poles 58 to 80	72,0	34,2 ± 0,3	68,4	2 ± 0,2

ⓘ No double sprocket holes for 12 pole numbers (tape size 24)

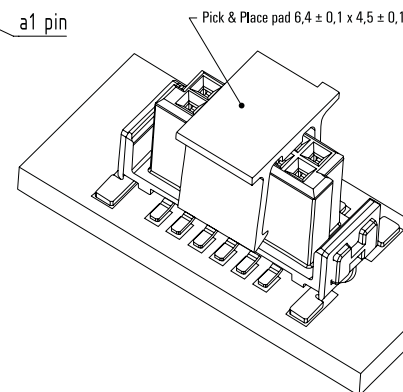

Reel - dimensions

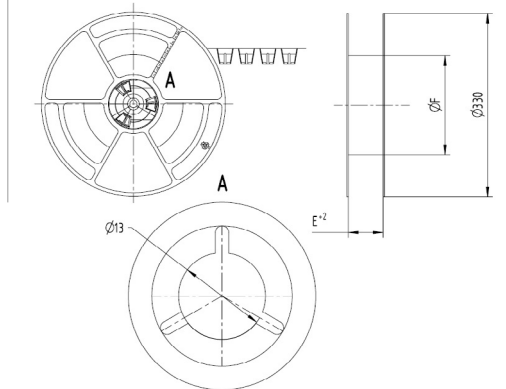

Reel dimensions	E	F
Pole 12	24,4	
Poles 14 to 20	32,4	
Poles 22 to 40	44,4	178mm for stacking height
Poles 42 to 56	56,4	1,75mm & 3,25mm
Poles 58 to 80	72,4	

Recommended reflow soldering profile

Weidmüller Interface GmbH & Co. KG
 Klingenbergstraße 16
 D-32758 Detmold
 Germany
 Fon: +49 5231 14-0
 Fax: +49 5231 14-292083
 www.weidmueller.com



Reflow soldering profile

The perfect soldering profile for SMT Surface Mount Technology is one the most exiting question in SMT production. But there are more than one correct answer: The diagram of temperature-on-time is related to processing features of solder paste and to maximum load of components.

We have to consider the following parameters:

- Time for pre heating
- Maximum temperature
- Time above melting point
- Time for cooling
- Maximum heating rate
- Maximum cooling rate

We recommend a typical solder profile with associated process limits. With preheating components and board are prepared smoothly for the solder phase. Heating rate is typically $\leq +3\text{K/s}$. In parallel the solder paste is ‚activated‘. The time above melting point of 217°C the paste gets liquid and components and boards begin to connect. The maximum temperature of 245°C to 254°C should stay between 10 and 40 seconds. In the cooling phase at $\geq -6\text{K/s}$ solder is cured. Board and components cool down while avoiding cold cracks.