

Data Sheet | Item Number: 831-3626/108-000

THT male header; 1.0 x 1.2 mm solder pin; angled; 100% protected against mismatching; Threaded flange; Pin spacing 7.62 mm; 6-pole; light gray

<https://www.wago.com/831-3626/108-000>

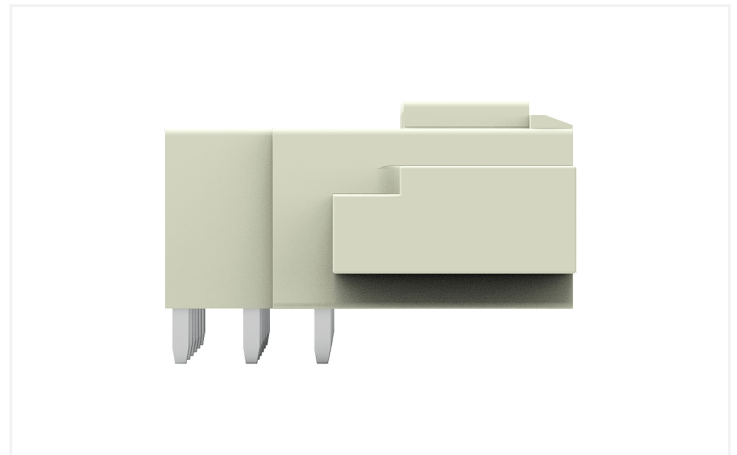

Color: ■ light gray

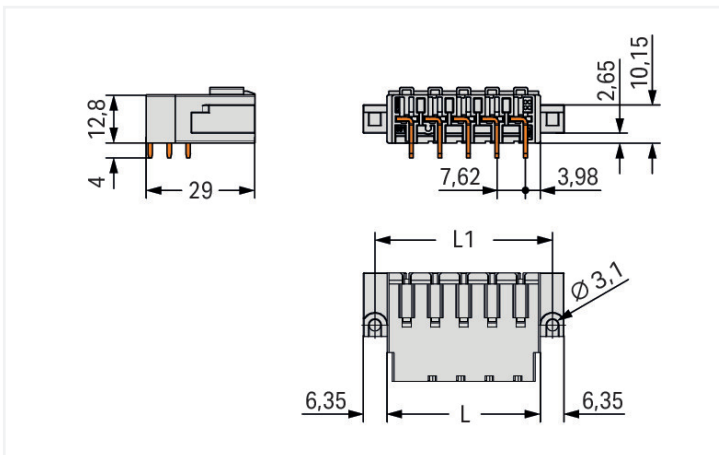
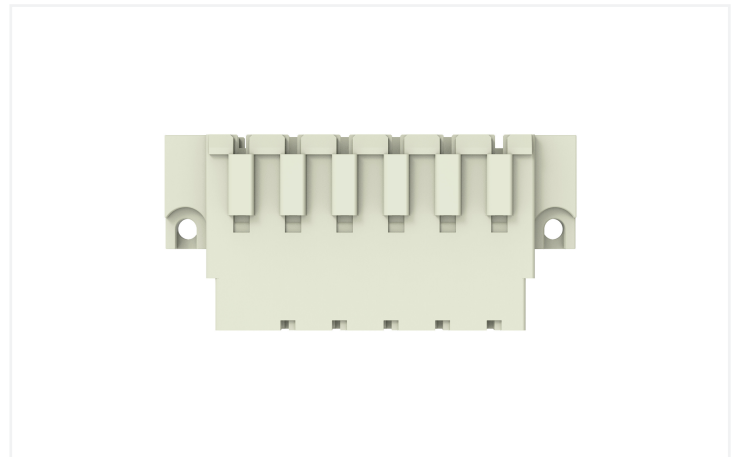
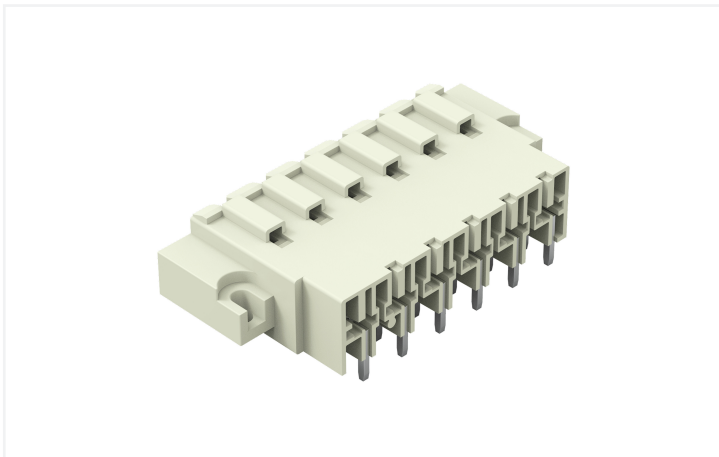

Dimensions in mm

$L = \text{pole no.} \times \text{pin spacing} + 2.9 \text{ mm}$

$L1 = L + 6.5 \text{ mm}$

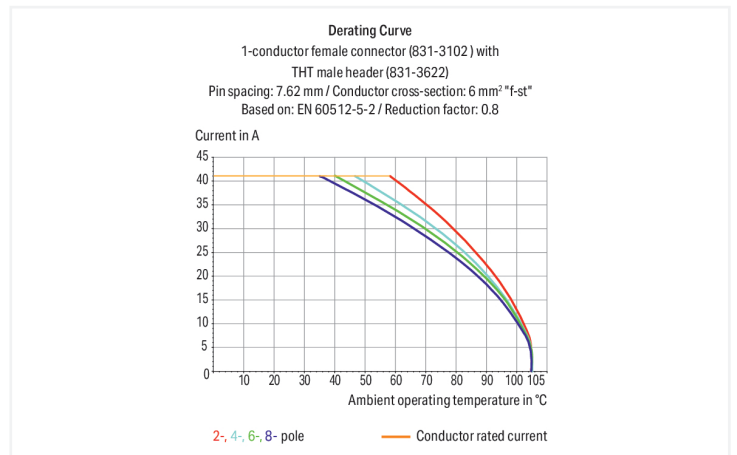

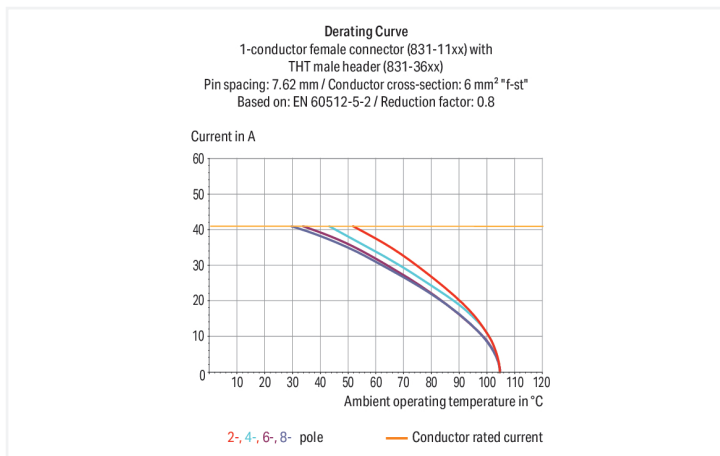

Stiftleiste Serie 831 mit Rastermaß 7,62 mm

Bei dieser Stiftleiste mit der Artikelnummer 831-3626/108-000 ist eine saubere Elektroinstallation der Fokus. Unsere Leiterplatten-Steckverbinder gewähren Ihnen die größtmögliche Flexibilität bei unterschiedlichen Montagearten. Die Abmessungen sind in Breite x Höhe x Tiefe (61,3 x 18,8 x 29) mm. Die Oberfläche der Kontakte ist aus Zinn. Das MCS – "Multi Connection System" von WAGO ist ein vielfältiges Steckverbindersystem für Ihre durchgängige Systemverdrahtung. Es ermöglicht Ihnen eine vereinfachte Verdrahtung in der Kabelvorkonfektionierung und auf Geräten durch zwei Betätigungsrichtungen für die CAGE CLAMP®-Varianten. Der Leiterplatten-Steckverbinder wird mittels THT verlötet.

Notes

Safety Information

The MCS – *MULTI CONNECTION SYSTEM* includes connectors without breaking capacity in accordance with DIN EN 61984. When used as intended, these connectors must not be connected/disconnected when live or under load. When used as intended, these connectors must not be connected/disconnected when live or under load. The circuit design should ensure header pins, which can be touched, are not live when unmated.

Variants:

Other pole numbers
Protection against PCB mounting errors
Other versions (or variants) can be requested from WAGO Sales or configured at <https://configurator.wago.com/>.

Electrical data

Ratings per	IEC/EN 60664-1			Approvals per	UL 1059		
Overvoltage category	III	III	II	Use group	B	C	D
Pollution degree	3	2	2	Rated voltage	-	300 V	600 V
Nominal voltage	500 V	630 V	1000 V	Rated current	-	42 A	5 A
Rated impulse withstand voltage	6 kV	6 kV	6 kV				
Rated current	41 A	41 A	41 A				

Approvals per	CSA		
Use group	B	C	D
Rated voltage	-	300 V	600 V
Rated current	-	41 A	5 A

Connection data

Total number of potentials	6	Connection 1	
Number of connection types	1	Pole number	6
Number of levels	1		

Physical data

Pin spacing	7.62 mm / 0.3 inches
Width	61.3 mm / 2.414 inches
Height	18.8 mm / 0.74 inches
Height from the surface	14.8 mm / 0.583 inches
Depth	29 mm / 1.142 inches
Solder pin length	4 mm
Solder pin dimensions	1 x 1.2 mm
Drilled hole diameter with tolerance	1.7 ^(+0.1) mm

Mechanical data

Variable coding	Yes
Anti-rotation protection	Yes

Plug-in connection

Contact type (pluggable connector)	Male connector/plug
Connector (connection type)	for PCB
Mismating protection	Yes
Mating direction to the PCB	0 °
Locking of plug-in connection	Threaded flange

PCB contact

PCB contact	THT
Solder pin arrangement	over the entire male connector (in-line)
Number of solder pins per potential	3

Material data

Note (material data)	Information on material specifications can be found here
Color	light gray
Material group	I
Insulation material (main housing)	Polyamide (PA66)
Flammability class per UL94	V0
Contact material	Electrolytic copper (E _{Cu})
Contact Plating	Tin
Fire load	0.307 MJ
Weight	18.6 g

Environmental requirements

Limit temperature range	-60 ... +105 °C	Environmental Testing
Processing temperature	-35 ... +60 °C	
		Test specification: Railway applications – Rolling stock – Electronic equipment
		DIN EN 50155 (VDE 0115-200):2022-06
		Test procedure: Railway applications – Rolling stock equipment – Vibration and shock tests
		DIN EN 61373 (VDE 0115-0106):2011-04
		Spectrum/Mounting location
		Service life test, Category 1, Class A/B
		Functional test with noise-like oscillations
		Test passed according to Section 8 of the standard
		Frequency
		f ₁ = 5 Hz to f ₂ = 150 Hz
		Acceleration
		0.101g (highest test level used for all axes)
		Test duration per axis
		10 min.
		Test directions
		X, Y and Z axes
		Monitoring of contact faults and interruptions
		Passed
		Voltage drop measurement before and after each axis
		Passed
		Simulated service life test through increased levels of noise-like oscillations
		Test passed according to Section 9 of the standard
		Frequency
		f ₁ = 5 Hz to f ₂ = 150 Hz
		Acceleration
		0.572g (highest test level used for all axes)
		Test duration per axis
		5 h
		Test directions
		X, Y and Z axes
		Extended testing: Monitoring of contact faults and interruptions
		Passed
		Extended testing: Voltage drop measurement before and after each axis
		Passed
		Shock test
		Test passed according to Section 10 of the standard
		Shock pulse form
		Half sine
		Acceleration
		5g (highest test level used for all axes)
		Shock duration
		30 ms
		Number of shocks (per axis)
		3 pos. und 3 neg.
		Test directions
		X, Y and Z axes
		Extended testing: Monitoring of contact faults and interruptions
		Passed
		Extended testing: Voltage drop measurement before and after each axis
		Passed
		Vibration and shock stress for rolling stock equipment
		Passed

Commercial data

PU (SPU)	24 pcs
Packaging type	Box
Country of origin	PL
GTIN	4066966089998
Customs tariff number	85366930000

Product Classification

UNSPSC	39121409
ETIM 9.0	EC002637
ETIM 8.0	EC002637
ECCN	NO US CLASSIFICATION

Environmental Product Compliance

CAS-No.	7439-92-1
REACH Candidate List Substance	Lead
RoHS Compliance Status	Compliant, No Exemption
SCIP notification number (Austria)	4f16a59e-8618-4e54-9003-cb0de9ac3a26
SCIP notification number (Belgium)	38c5072a-a56a-4a47-937b-ed595f6c3638
SCIP notification number (Bulgaria)	3be5f604-24f2-495e-bb99-fd2aae58ce92
SCIP notification number (Czech Republic)	8ef07e26-0355-45e8-b749-a2eb6d514677
SCIP notification number (Denmark)	88c6aff5-b579-4ff8-92cf-ad234c496707
SCIP notification number (Finland)	63cc6e05-0a8d-46c7-a556-d625598df493
SCIP notification number (France)	31ad1e78-acdb-43da-a196-1a727f81ec58
SCIP notification number (Germany)	2ad4203f-0cf4-454b-b8a7-278c094734c9
SCIP notification number (Hungary)	1e58d0ac-2614-47a6-bcbc-6bbd0093361e
SCIP notification number (Italy)	7a9d6160-6997-49d8-976b-9a1740b88e63
SCIP notification number (Netherlands)	e712025f-ba86-4ef3-ae7e-90038bcf676e
SCIP notification number (Poland)	81f42db9-a805-4ff4-add2-e5fb806e47c4
SCIP notification number (Romania)	79477254-5053-45f5-b8ab-e6d7bc212875
SCIP notification number (Sweden)	887220b3-c8ff-4ec0-bbf6-748a16e4394c

Approvals / Certificates

General approvals



Approval	Standard	Certificate Name
CB DEKRA Certification B.V.	IEC 61984	NL-61360/M1
KEMA/KEUR DEKRA Certification B.V.	EN 61984	71-116057
UL Underwriters Laboratories Inc.	UL 1059	UL-US-2426356-0

Declarations of conformity and manufacturer's declarations



Approval	Standard	Certificate Name
Railway WAGO GmbH & Co. KG	-	Railway Ready

Downloads

Environmental Product Compliance

Compliance Search

Environmental Product Compliance
831-3626/108-000



Documentation

Additional Information

Technical Section

03.04.2019

pdf

2027.26 KB



CAD/CAE-Data

CAD data

2D/3D Models
831-3626/108-000



CAE data

ZUKEN Portal
831-3626/108-000



PCB Design

Symbol and Footprint
via SamacSys
831-3626/108-000



Symbol and Footprint
via Ultra Librarian
831-3626/108-000



Installation Notes

Coding

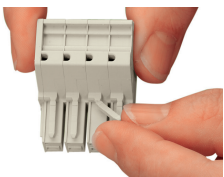

Break or cut off coding pin from female connector.

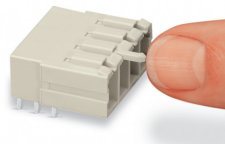

Insert coding pin into male header (break first) until it engages.

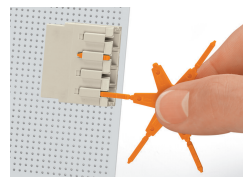

Coding a THT male header by inserting a coding pin.