

- 10 Watt in 1" x 1" package
- Shielded metal case with isolated baseplate
- Wide 2:1 input voltage ranges
- Operating temp. range  $-40^{\circ}\text{C}$  to  $+80^{\circ}\text{C}$  and up to  $+85^{\circ}\text{C}$  with heat-sink
- I/O isolation voltage 1500 VDC
- Input filter meets EN 55022 class A without external components
- Cost optimized design
- Industry standard pinout
- 3-year product warranty



UL 62368-1 IEC 62368-1

The THL 10 is a series of industrial 10 Watt DC/DC-converters packed in the compact 1" x 1" case and is a pin to pin replacement for the popular 1" x 2" size products. The industrial standard pinout, the wide 2:1 input voltage range and the input filter that meets EN 55032 Class A (conducted) without external components make these converters easy to design in and suitable for to cost optimize many existing and new applications.

The models have short circuit and overvoltage protection and are applicable in temperature ranges of up to  $+80^{\circ}\text{C}$  or  $+85^{\circ}\text{C}$  with optional mounted heat sink. Typical applications are instrumentation, distributed power architectures in communication and industrial electronics.

### Models

Order Code	Input Voltage Range	Output 1		Output 2		Efficiency typ.
		Vnom	I <sub>max</sub>	Vnom	I <sub>max</sub>	
THL 10-1210	9 - 18 VDC (12 VDC nom.)	3.3 VDC	2'500 mA			82 %
THL 10-1211		5.1 VDC	2'000 mA			85 %
THL 10-1212		12 VDC	830 mA			87 %
THL 10-1213		15 VDC	670 mA			88 %
THL 10-1221		+5 VDC	1'000 mA	-5 VDC	1'000 mA	84 %
THL 10-1222		+12 VDC	416 mA	-12 VDC	416 mA	87 %
THL 10-1223		+15 VDC	333 mA	-15 VDC	333 mA	87 %
THL 10-2410	18 - 36 VDC (24 VDC nom.)	3.3 VDC	2'500 mA			83 %
THL 10-2411		5.1 VDC	2'000 mA			85 %
THL 10-2412		12 VDC	830 mA			88 %
THL 10-2413		15 VDC	670 mA			89 %
THL 10-2421		+5 VDC	1'000 mA	-5 VDC	1'000 mA	85 %
THL 10-2422		+12 VDC	416 mA	-12 VDC	416 mA	88 %
THL 10-2423		+15 VDC	333 mA	-15 VDC	333 mA	89 %
THL 10-4810	36 - 75 VDC (48 VDC nom.)	3.3 VDC	2'500 mA			83 %
THL 10-4811		5.1 VDC	2'000 mA			85 %
THL 10-4812		12 VDC	830 mA			89 %
THL 10-4813		15 VDC	670 mA			89 %
THL 10-4821		+5 VDC	1'000 mA	-5 VDC	1'000 mA	86 %
THL 10-4822		+12 VDC	416 mA	-12 VDC	416 mA	87 %
THL 10-4823		+15 VDC	333 mA	-15 VDC	333 mA	88 %

### Options

THL-HS1	- Optional Heat Sink: <a href="http://www.tracopower.com/products/thl-hs1.pdf">www.tracopower.com/products/thl-hs1.pdf</a>
---------	--

## Input Specifications

Input Current	- At no load	12 Vin models: <b>15 mA typ.</b> 24 Vin models: <b>12 mA typ.</b> 48 Vin models: <b>10 mA typ.</b>
	- At full load	12 Vin models: <b>800 mA typ.</b> (3.3 Vout model) <b>1'000 mA typ.</b> (5.1 Vout model) <b>1'000 mA typ.</b> (12 Vout model) <b>1'000 mA typ.</b> (15 Vout model) <b>1'000 mA typ.</b> (5 / -5 Vout model) <b>1'000 mA typ.</b> (12 / -12 Vout model) <b>1'000 mA typ.</b> (15 / -15 Vout model) 24 Vin models: <b>400 mA typ.</b> (3.3 Vout model) <b>500 mA typ.</b> (5.1 Vout model) <b>500 mA typ.</b> (12 Vout model) <b>500 mA typ.</b> (15 Vout model) <b>500 mA typ.</b> (5 / -5 Vout model) <b>500 mA typ.</b> (12 / -12 Vout model) <b>500 mA typ.</b> (15 / -15 Vout model) 48 Vin models: <b>200 mA typ.</b> (3.3 Vout model) <b>250 mA typ.</b> (5.1 Vout model) <b>250 mA typ.</b> (12 Vout model) <b>250 mA typ.</b> (15 Vout model) <b>250 mA typ.</b> (5 / -5 Vout model) <b>250 mA typ.</b> (12 / -12 Vout model) <b>250 mA typ.</b> (15 / -15 Vout model)
Surge Voltage		12 Vin models: <b>25 VDC max.</b> (1 s max.) 24 Vin models: <b>50 VDC max.</b> (1 s max.) 48 Vin models: <b>100 VDC max.</b> (1 s max.)
Under Voltage Lockout		12 Vin models: <b>8.5 VDC max.</b> 24 Vin models: <b>17 VDC max.</b> 48 Vin models: <b>34 VDC max.</b> (Long term operation at undervoltage will damage the converter.)
Recommended Input Fuse		(The need of an external fuse has to be assessed in the final application.)
Input Filter		<b>Internal Pi-Type</b>

## Output Specifications

Voltage Set Accuracy		<b>±2% max.</b>
Regulation	- Input Variation (Vmin - Vmax)	single output models: <b>1% max.</b> dual output models: <b>1% max.</b>
	- Load Variation (0 - 100%)	single output models: <b>0.5% max.</b> dual output models: <b>1% max.</b> (Output 1) <b>1% max.</b> (Output 2)
	- Voltage Balance (symmetrical load)	dual output models: <b>2% max.</b>
	- Cross Regulation (25% / 100% asym. load)	dual output models: <b>5% max.</b>
Ripple and Noise (20 MHz Bandwidth)	- single output	3.3 Vout models: <b>80 mVp-p typ.</b>
		5.1 Vout models: <b>80 mVp-p typ.</b>
		12 Vout models: <b>100 mVp-p typ.</b>
		15 Vout models: <b>100 mVp-p typ.</b>
		5 / -5 Vout models: <b>80 / 80 mVp-p typ.</b>
- dual output	12 / -12 Vout models: <b>100 / 100 mVp-p typ.</b>	
	15 / -15 Vout models: <b>100 / 100 mVp-p typ.</b>	

All specifications valid at nominal voltage, resistive full load and +25°C after warm-up time, unless otherwise stated.

Capacitive Load	- single output	3.3 Vout models: 4'700 µF max. 5.1 Vout models: 2'200 µF max. 12 Vout models: 330 µF max. 15 Vout models: 220 µF max.
	- dual output	5 / -5 Vout models: 1'000 / 1'000 µF max. 12 / -12 Vout models: 150 / 150 µF max. 15 / -15 Vout models: 100 / 100 µF max.
Minimum Load		Not required
Temperature Coefficient		±0.02 %/K max.
Short Circuit Protection		Continuous, Automatic recovery
Output Current Limitation		110% min. of Iout max. 150% typ. of Iout max.
Transient Response	- Response Deviation	3% typ. / 5% max. (75% to 100% Load Step)
	- Response Time	300 µs typ. (75% to 100% Load Step)

### Safety Specifications

Safety Standards	- IT / Multimedia Equipment	CSA-C22.2, No. 60950-1 EN 60950-1 EN 62368-1 IEC 60950-1 IEC 62368-1 UL 60950-1 UL 62368-1
	- Certification Documents	<a href="http://www.tracopower.com/overview/thl10">www.tracopower.com/overview/thl10</a>
Pollution Degree		PD 3

### EMC Specifications

EMI Emissions	- Conducted Emissions	EN 55032 class A (with external filter) FCC Part 15 class A (with external filter)
	- Radiated Emissions	EN 55032 class A (with external filter) FCC Part 15 class A (with external filter)
	External filter proposal:	<a href="http://www.tracopower.com/overview/thl10">www.tracopower.com/overview/thl10</a>
EMS Immunity	- Electrostatic Discharge	Air: EN 61000-4-2, ±8 kV, perf. criteria A Contact: EN 61000-4-2, ±6 kV, perf. criteria A
	- RF Electromagnetic Field	EN 61000-4-3, 10 V/m, perf. criteria A
	- EFT (Burst) / Surge	EN 61000-4-4, ±2 kV, perf. criteria A EN 61000-4-5, ±1 kV, perf. criteria A
	- Conducted RF Disturbances	Ext. input component: 330 µF / 80 V EN 61000-4-6, 10 Vrms, perf. criteria A
	- PF Magnetic Field	Continuous: EN 61000-4-8, 3 A/m, perf. criteria A

### General Specifications

Relative Humidity		95% max. (non condensing)
Temperature Ranges	- Operating Temperature	-40°C to +80°C -40°C to +85°C (with Heat Sink)
	- Case Temperature	+100°C max.
	- Storage Temperature	-50°C to +125°C
Power Derating	- High Temperature	2.5 %/K above 60°C 3.3 %/K above 70°C (with Heat Sink)
	Cooling System	Natural convection (20 LFM)
Altitude During Operation		6'000 m max.
Switching Frequency		330 kHz typ. (PWM)
Insulation System		Functional Insulation
Isolation Test Voltage	- Input to Output, 60 s	1'500 VDC
	- Input to Output, 1 s	1'800 VDC
Isolation Resistance	- Input to Output, 500 VDC	1'000 MΩ min.

All specifications valid at nominal voltage, resistive full load and +25°C after warm-up time, unless otherwise stated.

Isolation Capacitance	- Input to Output, 100 kHz, 1 V	2'000 pF max.
Reliability	- Calculated MTBF	2'596'000 h (MIL-HDBK-217F, ground benign)
Washing Process		Allowed (hermetical product)
	See Cleaning Guideline:	<a href="http://www.tracopower.com/info/cleaning.pdf">www.tracopower.com/info/cleaning.pdf</a>
Housing Material		Alu alloy, black anodized coating
Base Material		Non-conductive FR4 (UL 94 V-0 rated)
Potting Material		Epoxy (UL 94 V-0 rated)
Pin Material		Copper Alloy (C6801)
Pin Foundation Plating		Nickel (2 - 4 µm)
Pin Surface Plating		Tin (5 - 7 µm), matte
Housing Type		Metal Case
Mounting Type		PCB Mount
Connection Type		THD (Through-Hole Device)
Footprint Type		1" x 1"
Soldering Profile		Wave Soldering 260°C / 10 s max.
Weight		15 g
Environmental Compliance	- REACH Declaration	<a href="http://www.tracopower.com/info/reach-declaration.pdf">www.tracopower.com/info/reach-declaration.pdf</a> REACH SVHC list compliant REACH Annex XVII compliant
	- RoHS Declaration	<a href="http://www.tracopower.com/info/rohs-declaration.pdf">www.tracopower.com/info/rohs-declaration.pdf</a> Exemptions: 7a (RoHS exemptions refer to the component concentration only, not to the overall concentration in the product (O5A rule). The SCIP number is provided on request.)

### Supporting Documents

Overview Link (for additional Documents)

[www.tracopower.com/overview/thl10](http://www.tracopower.com/overview/thl10)

### Outline Dimensions

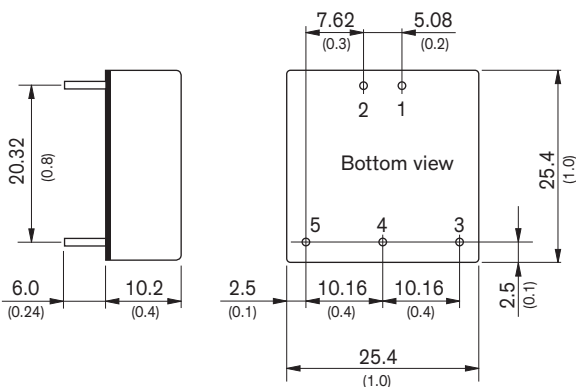

Dimensions in mm (inch)  
Tolerances:  $\pm 0.5$  ( $\pm 0.02$ )  
Pin pitch tolerances  $\pm 0.25$  (0.01)  
Pin diameter  $\varnothing 1.0$  ( $\varnothing 0.04$ )

Pinout		
Pin	Single	Dual
1	+Vin (Vcc)	+Vin (Vcc)
2	-Vin (GND)	-Vin (GND)
3	+Vout	+Vout
4	No pin	Common
5	-Vout	-Vout