

Ratings

Temperature: -40 ~ 70 °C
Voltage: 150 V

Conductor

Gauge: 28 AWG, 0.081 mm²
Material: tinned copper strands
Stranding: $\varnothing 0.05 \times 40$
Resistance at 20 °C: 240 Ω /km

Insulator

Material: HDPE
Color: black, white, red
Outer diameter: $\varnothing 0.7 \pm 0.10$ mm
Nominal thickness: 0.15 mm
Resistance at 20 °C: 100 M Ω /km

Shield

Type: spiral
Material: tinned copper strands
Strand size: $\varnothing 0.08$ mm
Coverage: 90 % minimum

Outer jacket

Material: TPU, 70 °C
Color: black
Nominal thickness: 0.55 mm
Diameter: $\varnothing 2.8 \pm 0.15$ mm

Filler

Material: aramid fiber

Tests

Tensile strength: 35.7 kgf
Dielectric test: 1500 V dc for 1 minute without breakdown
Bend test at 200 g, $\pm 90^\circ$, 30 cycles /min: 15,000 cycle minimum

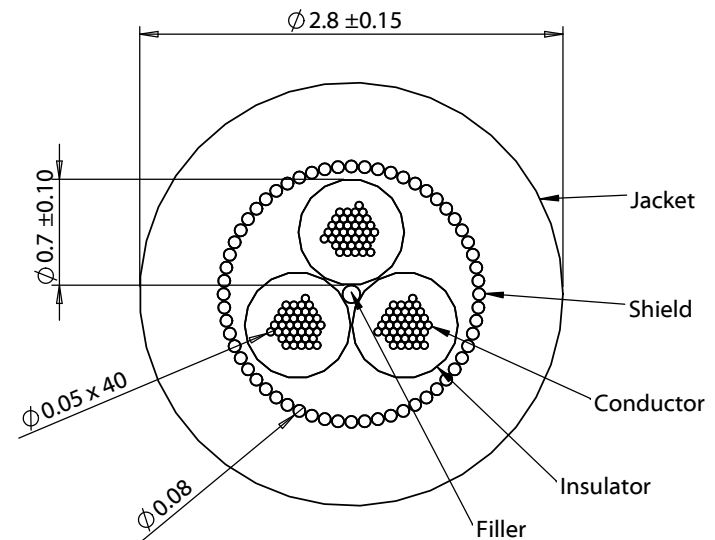
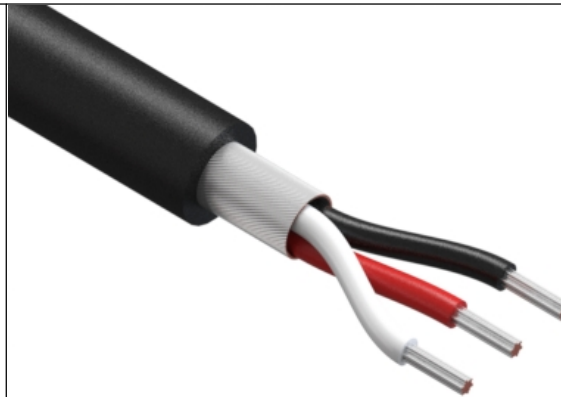

REVISION	DATE	DESCRIPTION
A	8/28/2015	Initial release
A1	1/13/2016	Updated notes, corrected tolerances
A2	1/17/2019	Changed filler material to generic name

PREPARED:
VERIFIED:
DIMENSIONS ARE IN MILLIMETERS
TOLERANCES:
X: ± 0.5 mm
X.X: ± 0.3 mm
X.XX: ± 0.05 mm

NOTES
RoHS and REACH compliant
Jacket meets ISO 10993 Biological Compatibility
Phthalate and halogen free
Function test: no open, no short, no intermittent
DESCRIPTION:
Wire, 3C TS, 28 AWG, 150V, 70C, 2.8 mm, spiral shield, TPU, WBL

TENSILITY
20802 Sockeye Place #130
Bend, OR 97701 USA
tel 541.323.3228 fax 541.323.4202
800 877.670.7118 www.tensility.com

SIZE	PART NUMBER
A	30-00495

SCALE: 20:1 SHEET 1 OF 1