

## HIGH-VIBRATION HIGH-PERFORMANCE TO-5 RELAY DPDT



SERIES	RELAY TYPE
412V	DPDT High-Vibration relay
412DV	DPDT High-Vibration relay, Internal Diode for coil transient suppression

### DESCRIPTION

The 412V TO-5 relays, originally conceived and developed by Teledyne, have become the industry standards for low level switching from dry circuit to 1 ampere in high-vibration environments. Designed for high-density PC board mounting, these TO-5 relays are some of the most versatile ultraminiature relay available because of their small size and low coil power dissipation.

The V Series high-vibration relays are designed to withstand vibration levels of 250 to 380 g's at the frequencies noted, when tested on a resonant beam for 10 to 20 seconds, in the axis parallel to contact motion (x-axis). A unique magnetic circuit prevents contact opening (chatter) in excess of 10 microseconds under vibration or shock conditions.

Typical applications:

- Avionics aircraft control
- Aircraft control systems
- Transportation systems (rail/truck)

By virtue of their inherently low intercontact capacitance and contact circuit losses, these TO-5 relays have proven to be excellent ultraminiature RF switches for applications with frequency ranges well into the UHF spectrum. A typical RF application for the TO-5 relay is in handheld radio transceivers, wherein the combined features of good RF performance, small size, low coil power dissipation and high reliability make it a preferred method of Transmit- Receive switching (see Figure 1). RF switches for applications with frequency ranges well into the UHF spectrum.

### ENVIRONMENTAL AND PHYSICAL SPECIFICATIONS

Temperature	-65°C to +125°C	
Vibration (General Note 1)	250 g's at 140 ±5Hz 350 g's at 170 ±5Hz 380 g's at 200 ±5Hz 100 g's to 1000 Hz 50 g's to 2000 Hz	
Shock (General Note 1)	75 g's 6msec, half-sine	
Acceleration	50 g's	
Enclosure	Hermetically Sealed	
Weight	412V	0.09 oz. (2.55g) max.

### INTERNAL CONSTRUCTION

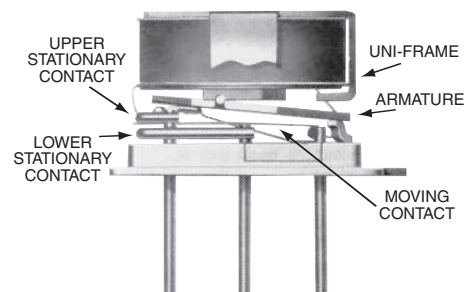

**SERIES 412V**  
**GENERAL ELECTRICAL SPECIFICATIONS (@25°C)**

<b>Contact Arrangement</b>		2 Form C (DPDT)
<b>Rated Duty</b>		Continuous
<b>Contact Resistance</b>		0.10 $\Omega$ max. before life; 0.20 $\Omega$ max. after life @ 1A/28Vdc
<b>Contact Load Rating (DC)</b>		Resistive: 1 A / 28 Vdc Inductive: 200 mA / 28 Vdc (320mH) Lamp: 100 mA / 28 Vdc (320mH) Low level: 10 to 50 $\mu$ A @ 10 to 50 mV
<b>Contact Load Rating (AC)</b>		Resistive: 250 mA / 115Vac, 60 and 400 Hz (Case not grounded) 100 mA / 115 Vac, 60 and 400 Hz (Case grounded)
<b>Contact Life Ratings</b>		10,000,000 cycles (typical) at low level 1,000,000 cycles (typical) at 0.5 A / 28 Vdc resistive 100,000 cycles min. at all other loads specified above
<b>Contact Overload Rating</b>		2 A / 28 Vdc Resistive (100 cycles min.)
<b>Coil Operating Power</b>	<b>412V</b>	620 mW typical at nominal rated voltage
<b>Operate Time</b>	<b>412V</b>	3.0 ms max.
<b>Contact Carry Rating</b>		Contact Factory
<b>Release Time</b>	<b>412V</b>	2.0 ms max.
	<b>412DV</b>	4.0 ms max.
<b>Contact Bounce</b>		1.5 ms
<b>Intercontact Capacitance</b>		0.4 pf typical
<b>Insulation Resistance</b>		1,000 M $\Omega$ min. between mutually isolated terminals
<b>Dielectric Strength</b>		Atmospheric: 500 Vrms (60 Hz)      70,000 ft: 125 Vrms (60 Hz)

**SERIES 412V**  
**DETAILED ELECTRICAL SPECIFICATIONS (@25°C)**

BASE PART NUMBERS (412V)		412V-5 412DV-5	412V-12 412DV-12	412V-26 412DV-26	
Coil Voltage		Nom.	5.0	12.0	26.5
		Max.	5.8	16.0	32.0
Drop-Out Voltage (Vdc)	412V 412DV	Min.	0.14	0.41	0.89
		Max.	2.3	6.5	13.0
Coil Resistance (Ohms ±10%)	412V	50	235	1130	
	412DV	33	215	1050	
Pick-up Voltage (Vdc, Max.) Pulse Operation		4.7	11.0	22.0	

**PERFORMANCE CURVES (Note 2)**

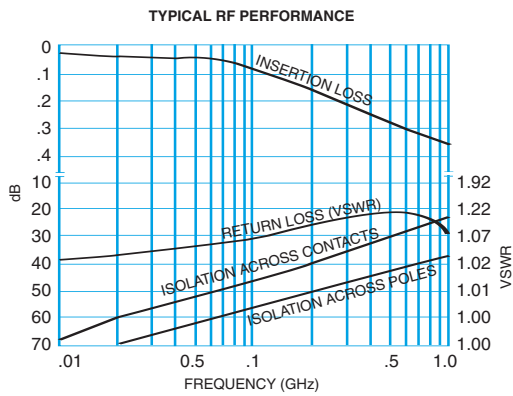

**FIGURE 1**

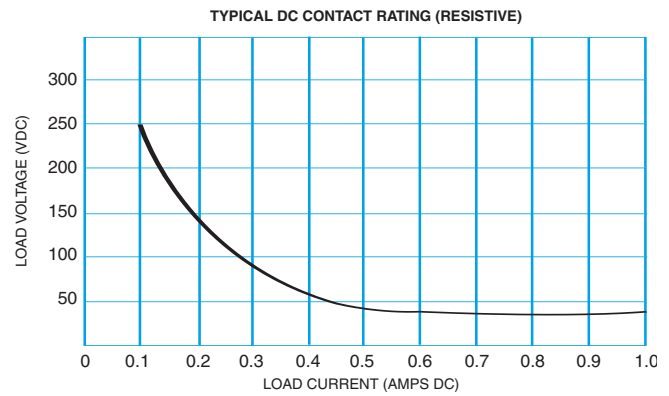

**FIGURE 2**

**SERIES 412V / 432V  
OUTLINE DIMENSIONS**

DIMENSION "A" MAX.	
412V	.270 (6.86)
432V	.375 (9.52)

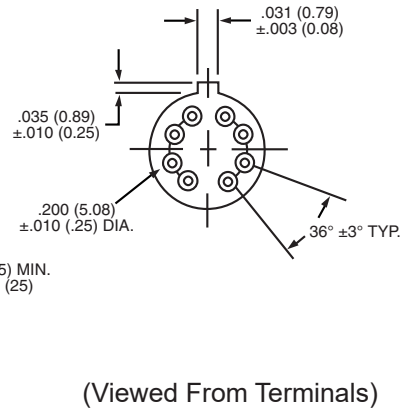
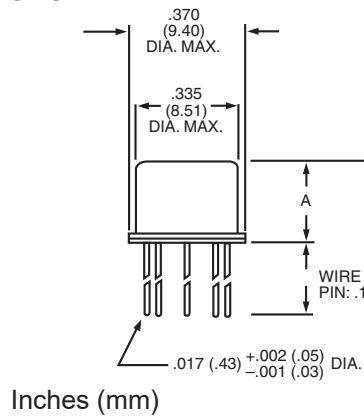

**SCHEMATIC DIAGRAMS**

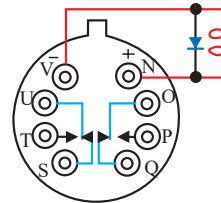
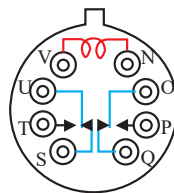

**High Performance Relays**

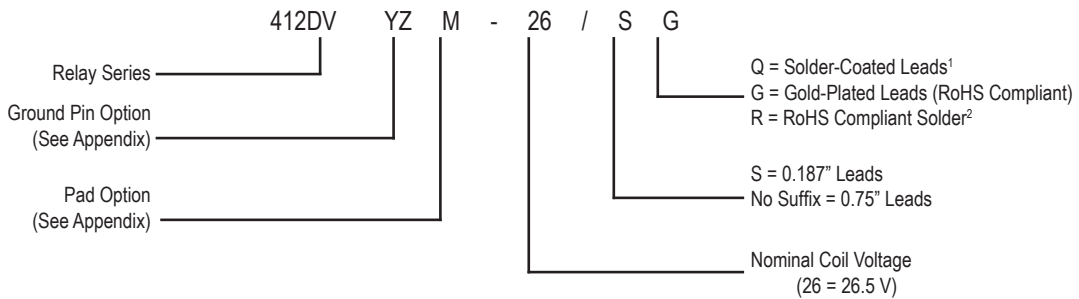

General Note: Parts ordered without suffix may be supplied with Solder-Coated or Gold-Plated leads.  
 1 Parts ordered with Solder-Coated leads will have (Sn60/Pb40)  
 2 Parts ordered with RoHS Solder-Coated leads will have (Sn99.3/Cu0.7)

**NOTES:**

1. Relay contacts will exhibit no chatter in excess of 10 μsec or transfer in excess of 1 μsec.
2. "Typical" characteristics are based on available data and are best estimates. No ongoing verification tests are performed.
3. Unless otherwise specified, parameters are initial values.
4. Measured at nominal voltage for 5 sec. maximum.

## APPENDIX A : Spacer Pads

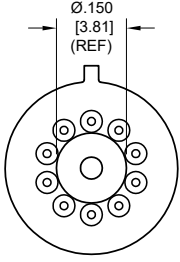
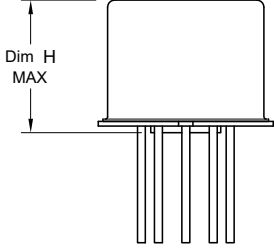
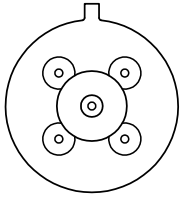
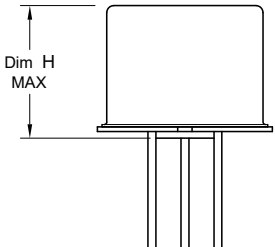
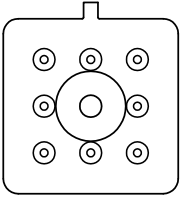
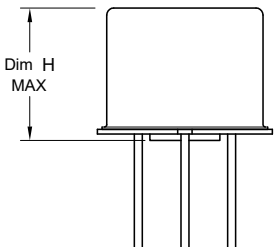
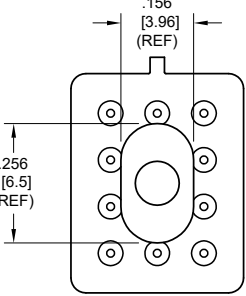
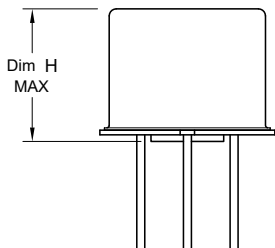
Pad designation and bottom view dimensions	Height	For use with the following:	Dim. H Max.
 <p style="text-align: center;">“M4” Spacer Pad for TO-5</p>		ER412	.295 (7.49)
		712, RF300, RF, RF700, RF703	.300 (7.62)
		ER422, 722	.305 (7.75)
		ER432	.400 (10.16)
		732, RF303	.410 (10.41)
		RF312	.350 (8.89)
 <p style="text-align: center;">“M4”Spacer Pad for TO-5</p>		ER411	.295 (7.49)
		RF311	.300 (7.62)
		RF331	.410 (10.41)
 <p style="text-align: center;">“M4” Spacer Pad for Centigrid®</p>		172	.305 (7.75)
		ER114, J114	.300 (7.62)
		ER134, J134	.400 (10.16)
		RF100	.315 (8.00)
		RF103	.420 (10.67)
 <p style="text-align: center;">“M9”Spacer Pad for Centigrid®</p>		122C, A152	.320 (8.13)
		ER116C, J116C	.300 (7.62)
		ER136C, J136C	.400 (10.16)
		RF180	.325 (8.25)
		A150	.305 (7.75)

**Notes:**

1. Spacer pad material: Polyester film.
2. To specify an “M4” or “M9” spacer pad, refer to the mounting variants portion of the part numbering example in the applicable datasheet.
3. Dimensions are in inches (mm).
4. Unless otherwise specified, tolerance is  $\pm .010$  (.25 mm).
5. Add 10 m $\Omega$  to the contact resistance shown in the datasheet.
6. Add 0.01 oz. (0.25 g) to the weight of the relay assembly shown in the datasheet.

## APPENDIX A : Spreader Pads

Pad designation and bottom view dimensions	Height	For use with the following:	Dim. H Max.
<p style="text-align: center;">“M” Spreader Pad <u>5/</u> <u>6/</u></p>		ER411T, ER412, J412	.388 (9.86)
		712	.393 (9.99)
		ER432, J432	.493 (12.52)
		732	.503 (12.78)
		J421, J422, ER422, 722	.398 (10.11)

**Notes:**

1. Spreader pad material: Diallyl Phthalate.
2. To specify an “M”, “M2” or “M3” spreader pad, refer to the mounting variants portion of the part number example in the applicable datasheet.
3. Dimensions are in inches (mm).
4. Unless otherwise specified, tolerance is  $\pm .010$ ” (0.25 mm).
- 5/. Add 25 m $\Omega$  to the contact resistance shown in the datasheet.
- 6/. Add .01 oz. (0.25 g) to the weight of the relay assembly shown in the datasheet.
- 7/. Add 50 m $\Omega$  to the contact resistance shown in the datasheet.
- 8/. Add 0.025 oz (0.71 g) to the weight of the relay assembly shown in the datasheet.
- 9/. M3 pad to be used only when the relay has a center pin (e.g. ER411M3-12A, 722XM3-26.)

# APPENDIX A : Ground Pin Positions

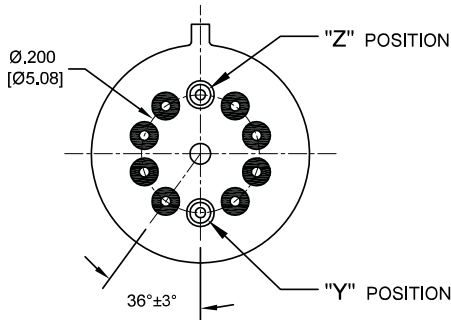

### TO-5 Relays:

ER412, ER412T, ER422, ER432, ER432T, 712, 712TN, 400H, 400K, 400V, RF300, RF303, RF341, RF312, RF332, RF310, RF313, RF320, RF323, SI800, SI803, RF700, RF703

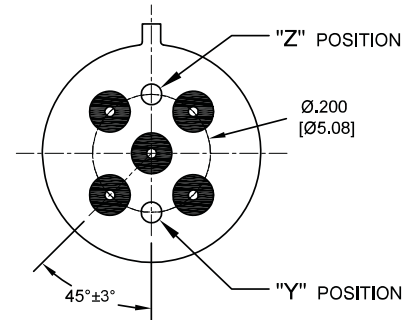

### TO-5 Relays:

ER411, RF311, RF331

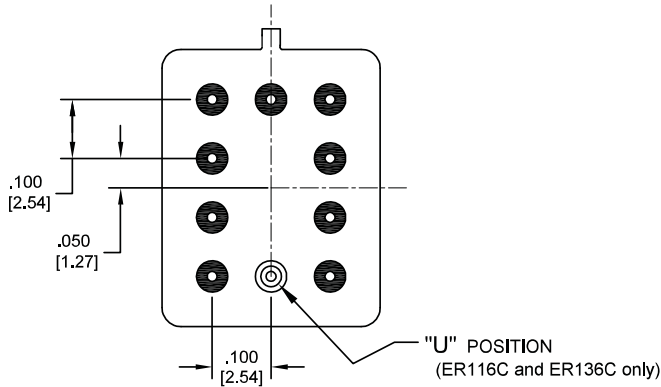

### Centigrid® Relays:

RF180, ER116C, 122C, ER136C

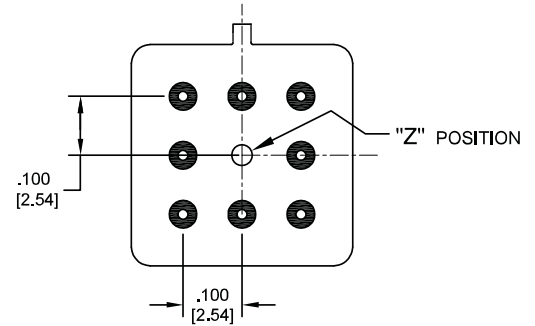

### Centigrid® Relays:

RF100, RF103, ER114, ER134, 172

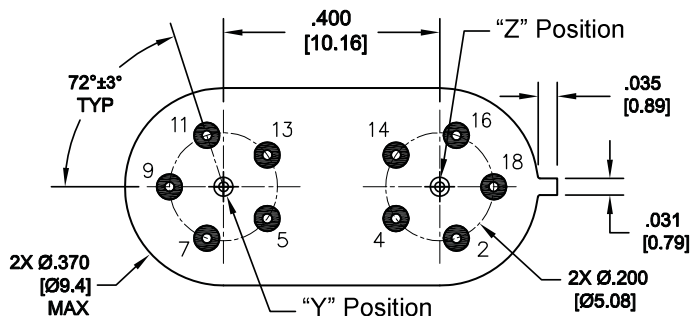

### Loopback Relays:

LB363

### NOTES

1. Terminal views shown
  2. Dimensions are in inches (mm)
  3. Tolerances:  $\pm .010$  ( $\pm .25$ ) unless otherwise specified
  4. Ground pin positions are within  $.015$  ( $0.38$ ) dia. of true position
  5. Ground pin head dia.,  $0.035$  ( $0.89$ ) ref: height  $0.010$  ( $0.25$ ) ref.
  6. Lead dia.  $0.017$  ( $0.43$ ) nom.
- Indicates ground pin position
  - Indicates glass insulated lead position
  - ⊙ Indicates ground pin or lead position depending on relay type