

ULTRA-SMALL PRESSURE SENSOR



Product Number: SM6841

HIGHLIGHTS

- Small, low cost, robust SO8 package
- For high-volume applications
- Miniature Form Factor

TYPICAL APPLICATIONS

- Automotive tire pressure (TPMS)
- Engine control
- Barometric sensing
- Altitude correction detection
- Pneumatic gauges
- Home appliances
- Pressure Switches

BASICS

- Absolute pressure
- PCB mountable
- Center Hole
- Tape and reel

FEATURES

- 30 & 100 PSI (200 & 700 kPa)
- Wide temperature range (-40° to +125°C)
- Suitable for automated assembly
- Constant current or constant voltage drive
- High millivolt output
- RoHS & REACH Compliant



SOIC8 Packaged Pressure Sensor

DESCRIPTION

The SM6841 is a small outline SO-8 packaged pressure sensor that incorporates SMI's SM5108C MEMS piezoresistive pressure sensing die. The SM6841 has been optimized to provide the highest possible accuracy for a package of this size. Performance is achieved through careful resistor placement and mechanical configuration along with advanced MEMS processing.

The packaged sensor is intended for high volume applications where cost is a critical factor, such as consumer and automotive products. The SM6841 is available as an absolute pressure sensor in full-scale range of 30 & 100 PSI (200 & 700 kPa). It is designed to be surface-mounted on ceramic or PC board substrates by high-volume OEM manufacturers.

The SM6841 is available in a non-ported, centered hole, configuration that is designed to be immersed in the media being measured.

The standard configuration offers a protective gel over the die. A non-gel version is also available for high volumes where the maximum stability is required, such as in barometric, weather station sensing applications. The SM6841 is shipped tape & reel.

Product Number: SM6841

ABSOLUTE MAXIMUM RATING TABLE FOR SM6841 SENSOR

All parameters are specified at $V_{SUPPLY} = 5.00$ V DC supply at room temperature, unless otherwise noted. All parts are covered with gel.

No.	Characteristic	Symbol	Minimum	Typical	Maximum	Units
1	Excitation Voltage ^(a)	V_{SUPPLY}	0.0	5.0	10.0	V
2	Excitation Current ^(a)	I_{SUPPLY}	0.0	1.0	1.6	mA
3	Proof Pressure ^(b, c)	p_{PROOF}	3×	—	—	FS pRANGE
4	Burst Pressure ^(b, d)	p_{BURST}	5×	—	—	FS pRANGE
5	Operating Temperature ^(b)	T_{OP}	-40	—	+125	°C
6	Storage Temperature ^(b)	T_{STG}	-55	—	+150	°C

NOTES:

- (a) The device can only be driven with the supply voltage connected to the pins as shown. The positive output will increase with increasing pressure applied to the package.
- (b) Tested on a sample basis.
- (c) Proof Pressure is 3X or 220 PSI, whichever is less
- (d) Burst Pressure is 5X or 220 PSI, whichever is less

OPERATING CHARACTERISTICS FOR SM6841 SENSOR - SPECIFICATIONS

All parameters are specified at $V_{SUPPLY} = 5.00$ V DC supply at room temperature, unless otherwise noted. All parts are covered with gel.

No.	Characteristic	Symbol	Minimum	Typical	Maximum	Units
7	Span (30 & 100 PSI) ^(g)	V_{SPAN}	65	100	135	mV
8	Zero Offset	V_{ZERO}	-35	0	35	mV
9	TC Span ^(b, g)	TCS	-0.24	-0.19	-0.155	%FS/°C
10	TC Zero Offset ^(b, g)	TCZ	-0.07	-0.01	+0.07	%FS/°C
11	TC Resistance ^(b, e, g)	TCR	0.24	0.275	0.33	% R_B /°C
12	Linearity ^(f)	NL	-0.2	-0.07	0.2	%FS
13	Bridge Resistance	R_B	4.0	5.0	6.0	k Ω
14	Input Capacitance ^(b)	C_{IN}	—	< 2	—	pF

NOTES:

- (e) Determined by measurements taken at 0°C and 70°C.
- (f) Defined as best fit straight line.
- (g) For specifications regarding zero offset and span stability, please contact SMI Sales at +1-(408) 577-0100 or sales@si-micro.com

QUALIFICATION STANDARDS

- REACH compliant
- RoHS compliant
- PFOS/PFOA compliant
- For qualification specifications please contact Sales at sales@si-micro.com



Product Number: SM6841

Diagrams and Dimensions

H(ole) Configuration

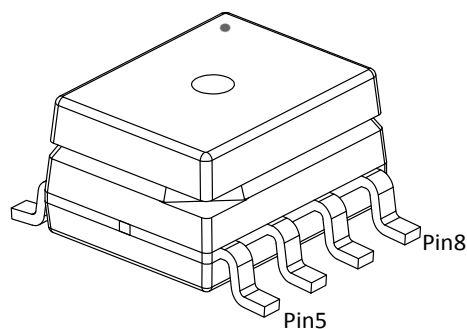
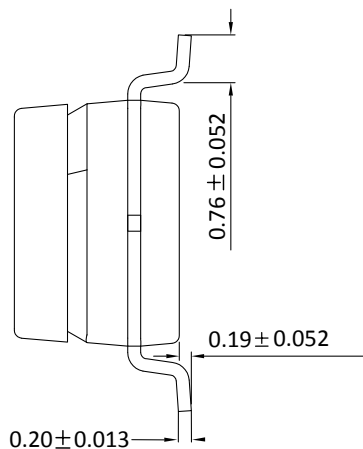
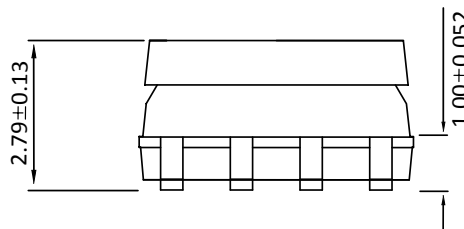
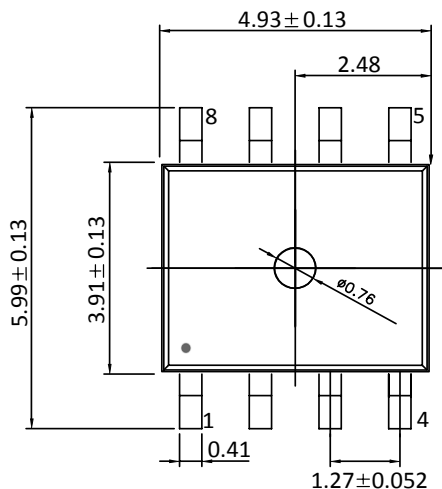

Note: • All dimensions in mm
• MSL = 3

Pin-Out

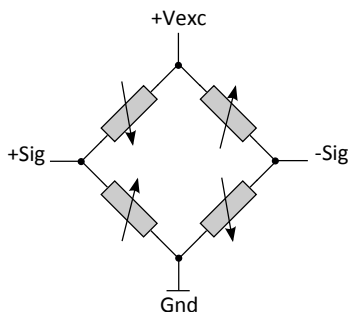

PIN	DESCRIPTION
1	NC
2	+Sig
3	NC
4	Gnd
5	NC
6	-Sig
7	NC
8	+Vexc

Typical Operation

PIN	DESCRIPTION	TYPE	VALUE
2	+Sig	Analog Out	-
4	Gnd	Gnd	0 V
6	-Sig	Analog Out	-
8	+Vexc	Power	+5 V

Ordering Information

Order Code	Full-Scale Pressure Range	Pressure Type	Minimum Order Quantity
SM6841-030-A-H-T	30 PSI / 200 kPa	Absolute	2,000 units
SM6841-100-A-H-T	100 PSI / 700 kPa		

For samples, please contact the Sales Department at: sales@si-micro.com

Product Number: SM6841

Silicon Microstructures Warranty and Disclaimer:

Silicon Microstructures, Inc. reserves the right to make changes without further notice to any products herein and to amend the contents of this data sheet at any time and at its sole discretion.

Information in this document is provided solely to enable software and system implementers to use Silicon Microstructures, Inc. products and/or services. No express or implied copyright licenses are granted hereunder to design or fabricate any silicon-based microstructures based on the information in this document.

Silicon Microstructures, Inc. makes no warranty, representation, or guarantee regarding the suitability of its products for any particular purpose, nor does Silicon Microstructures, Inc. assume any liability arising out of the application or use of any product or silicon-based microstructure, and specifically disclaims any and all liability, including without limitation consequential or incidental damages. "Typical" parameters which may be provided in Silicon Microstructure's data sheets and/or specifications can and do vary in different applications and actual performance may vary over time. All operating parameters, including "Typicals", must be validated for each customer application by customer's technical experts. Silicon Microstructures, Inc. does not convey any license under its patent rights nor the rights of others. Silicon Microstructures, Inc. makes no representation that the circuits are free of patent infringement. Silicon Microstructures, Inc. products are not designed, intended, or authorized for use as components in systems intended for surgical implant into the body, or other applications intended to support or sustain life, or for any other application in which the failure of the Silicon Microstructures, Inc. product could create a situation where personal injury or death may occur. Should Buyer purchase or use Silicon Microstructures, Inc. products for any such unintended or unauthorized application, Buyer shall indemnify and hold Silicon Microstructures, Inc. and its officers, employees, subsidiaries, affiliates, and distributors harmless against all claims, costs, damages, and expenses, and reasonable attorney fees arising out of, directly or indirectly, any claim of personal injury or death associated with such unintended or unauthorized use, even if such claim alleges that Silicon Microstructures, Inc. was negligent regarding the design or manufacture of the part.

Silicon Microstructures, Inc. warrants goods of its manufacture as being free of defective materials and faulty workmanship. Silicon Microstructures, Inc. standard product warranty applies unless agreed to otherwise by Silicon Microstructures, Inc. in writing; please refer to your order acknowledgement or contact Silicon Microstructures, Inc. directly for specific warranty details. If warranted goods are returned to Silicon Microstructures, Inc. during the period of coverage, Silicon Microstructures, Inc. will repair or replace, at its option, without charge those items it finds defective. The foregoing is buyer's sole remedy and is in lieu of all warranties, expressed or implied, including those of merchantability and fitness for a particular purpose. In no event shall Silicon Microstructures, Inc. be liable for consequential, special, or indirect damages.

While Silicon Microstructures, Inc. provides application assistance personally, through its literature and the Silicon Microstructures, Inc. website, it is up to the customer to determine the suitability of the product for its specific application. The information supplied by Silicon Microstructures, Inc. is believed to be accurate and reliable as of this printing. However, Silicon Microstructures, Inc. assumes no responsibility for its use. Silicon Microstructures, Inc. assumes no responsibility for any inaccuracies and/or errors in this publication and reserves the right to make changes without further notice to any products or specifications herein

Silicon Microstructures, Inc.TM and the Silicon Microstructures, Inc. logo are trademarks of Silicon Microstructures, Inc. All other service or product names are the property of their respective owners.

© Silicon Microstructures, Inc. 2001-2017. All rights reserved.