

86A



- 316L SS Pressure Sensor
- Small Profile
- 0.5 - 4.5V High Level Output
- Gage, Absolute
- ASIC Calibrated

(Image displays Absolute type)



DESCRIPTION

The 86A is a small profile, media compatible, piezoresistive silicon pressure sensor packaged in a 316L stainless steel housing. The 86A is designed for o-ring mounting. The sensing package utilizes silicone oil to transfer pressure from the 316L stainless steel diaphragm to the sensing element.

The 86A is designed for high performance, low pressure applications. A custom ASIC is used for temperature compensation, offset correction, and provides an amplified output of 0.5 to 4.5V.

For a similar sensor with a plastic threaded fitting, refer to the LM pressure transducer.

FEATURES

- O-Ring Mount
- -20°C to +85°C Operating Temperature Range
- ±1.0% Pressure Non Linearity
- Down to ±3.0% Total Error Band
- Solid State Reliability

APPLICATIONS

- Level Controls
- Tank Level Measurement
- OEM Equipment
- Corrosive Fluids and Gas Measurement Systems
- Sealed Systems
- Manifold Pressure Measurement
- Barometric Pressure Measurement
- Submersible Depth Monitoring

STANDARD RANGES

Range	psig	psia	Range	Barg	Bara
0 to 1	•		0 to .07	•	
0 to 2	•		0 to .14	•	
0 to 5	•		0 to .35	•	
0 to 15	•	•	0 to 1	•	•
0 to 30	•	•	0 to 2	•	•
0 to 50	•	•	0 to 5	•	•
0 to 100	•	•	0 to 7	•	•
0 to 150	•	•	0 to 10	•	•

Intermediate ranges available, contact factory.

PERFORMANCE SPECIFICATIONS

Supply Voltage: 5.0Vdc

Ambient Temperature: 25°C (unless otherwise specified)

PARAMETERS	MIN	TYP	MAX	UNITS	NOTES
Full Scale Output Span		4.5		V	
Zero Pressure Output (Offset)		0.5		V	
Pressure Non Linearity	-1	±0.3	1	%Span	1
Pressure Hysteresis	-0.1		0.1	%Span	
Repeatability		±0.02		%Span	
Temperature Error – Span (0°C to 40°C)		1, 2psi and .07bar: ±2.0 ≥5psi or ≥.35bar: ±1.5		%Span	2
Temperature Error – Zero (0°C to 40°C)		1, 2psi and .07bar: ±2.0 ≥5psi or ≥.35bar: ±1.5		%Span	2
Accuracy (combined linearity, hysteresis, & repeatability)		0.25		%Span	1
Total Error Band (includes calibration errors above & temperature effects over the compensated range)		1, 2psi and .07bar: ±7 5psi and .35bar: ±5 >5psi or .35bar: ±3		%Span	
Supply Voltage	4.75	5.00	5.25	V	3
Insulation Resistance (50Vdc)	50			MΩ	4
Pressure Overload			3X	Rated	
Compensated Temperature	0		+40	°C	
Operating Temperature	-20		+85	°C	
Media – Pressure Port	Liquids and Gases compatible with 316L Stainless Steel				

Notes

1. Best fit straight line.
2. Over the compensated temperature range with respect to 25°C.
3. Guarantees output/input ratiometricity.
4. Between case and sensing element.
5. The maximum pressure that can be applied to a transducer without rupture of either the sensing element or transducer.

DIMENSIONS

DIMENSIONS ARE IN INCHES [mm]

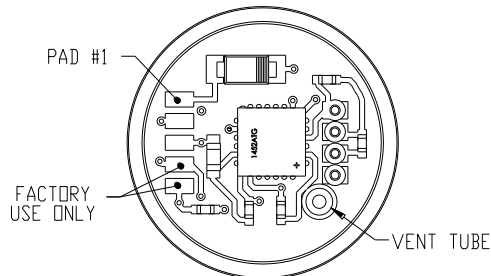
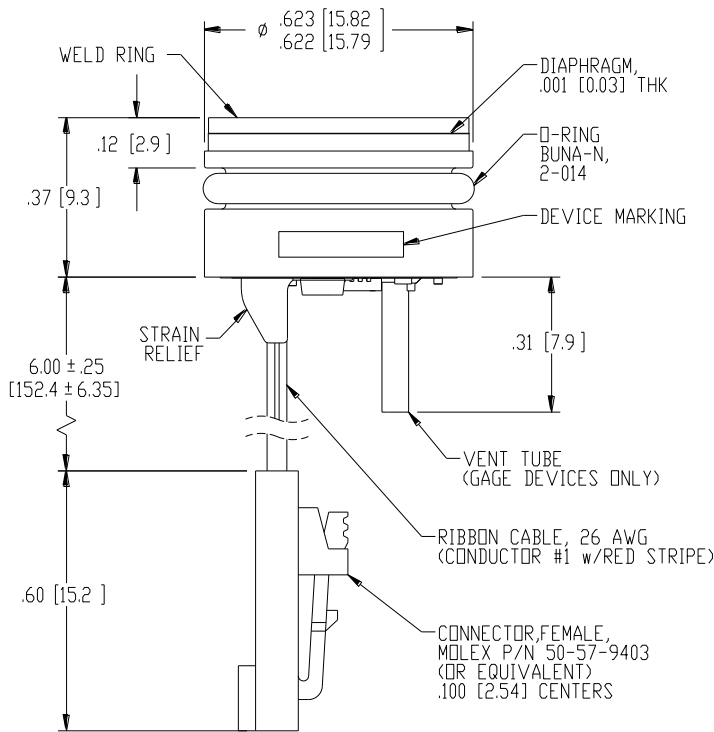

VIEW SHOWN w/o CABLE AND CONNECTOR FOR CLARITY

PAD/WIRE NO	FUNCTION
1	+Vin
2	GND
3	+Vout

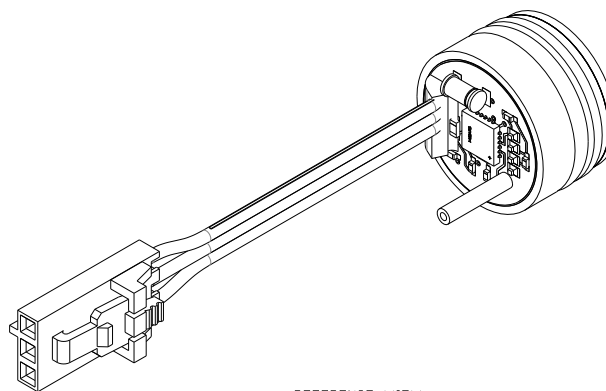

REFERENCE VIEW (GAGE DEVICE SHOWN)

ORDERING INFORMATION

86A 3 R - 00000 0 - 150P G

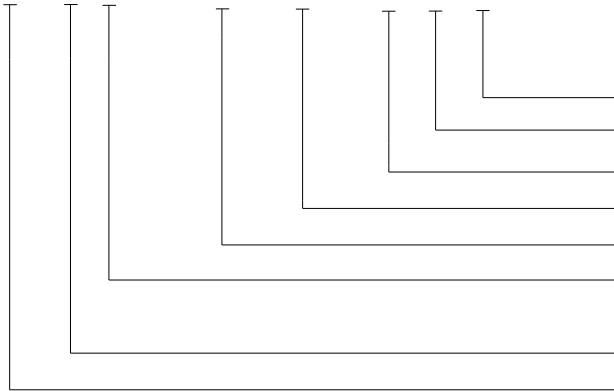

Pressure Unit (G = Gage, A = Absolute)
 Units (P = psi, B = Bar)
 Pressure Range
 Port Type (0 = Standard, X = Special)
 Custom P/N (00000 = Standard Product)
 Connection (R = 6" Ribbon Cable, C = 6" Ribbon Cable with Connector,
 X = Special Connection)
 Output (3 = 0.5 to 4.5V, X = Special Output)
 Model

NORTH AMERICA

Measurement Specialties
 45738 Northport Loop West
 Fremont, CA 94538
 Tel: 1-800-767-1888
 Fax: 1-510-498-1578
 Sales: pfg.cs.amer@meas-spec.com

EUROPE

Measurement Specialties
 (Europe), Ltd.
 26 Rue des Dames
 78340 Les Clayes-sous-Bois, France
 Tel: +33 (0) 130 79 33 00
 Fax: +33 (0) 134 81 03 59
 Sales: pfg.cs.emea@meas-spec.com

ASIA

Measurement Specialties
 (China), Ltd.
 No. 26 Langshan Road
 Shenzhen High-Tech Park (North)
 Nanshan District, Shenzhen 518057
 China
 Tel: +86 755 3330 5088
 Fax: +86 755 3330 5099
 Sales: pfg.cs.asia@meas-spec.com

The information in this sheet has been carefully reviewed and is believed to be accurate; however, no responsibility is assumed for inaccuracies. Furthermore, this information does not convey to the purchaser of such devices any license under the patent rights to the manufacturer. Measurement Specialties, Inc. reserves the right to make changes without further notice to any product herein. Measurement Specialties, Inc. makes no warranty, representation or guarantee regarding the suitability of its product for any particular purpose, nor does Measurement Specialties, Inc. assume any liability arising out of the application or use of any product or circuit and specifically disclaims any and all liability, including without limitation consequential or incidental damages. Typical parameters can and do vary in different applications. All operating parameters must be validated for each customer application by customer's technical experts. Measurement Specialties, Inc. does not convey any license under its patent rights nor the rights of others.