

J-Line™ Interconnection Systems

J-Line™
4P4W Max.
30 through 200A

Robust service in metal for many industrial applications, the J-Line™ offers a value alternative to MaxGard® in 3P4W, 30–200 Amp applications with less severe needs. Unique among competitors, the J-Line™ uses a reversible contract carrier for maximum flexibility in many portable service applications.

Design Features

Russellstoll® J-Line™ Load-Breaking Plugs, Connectors and Receptacles

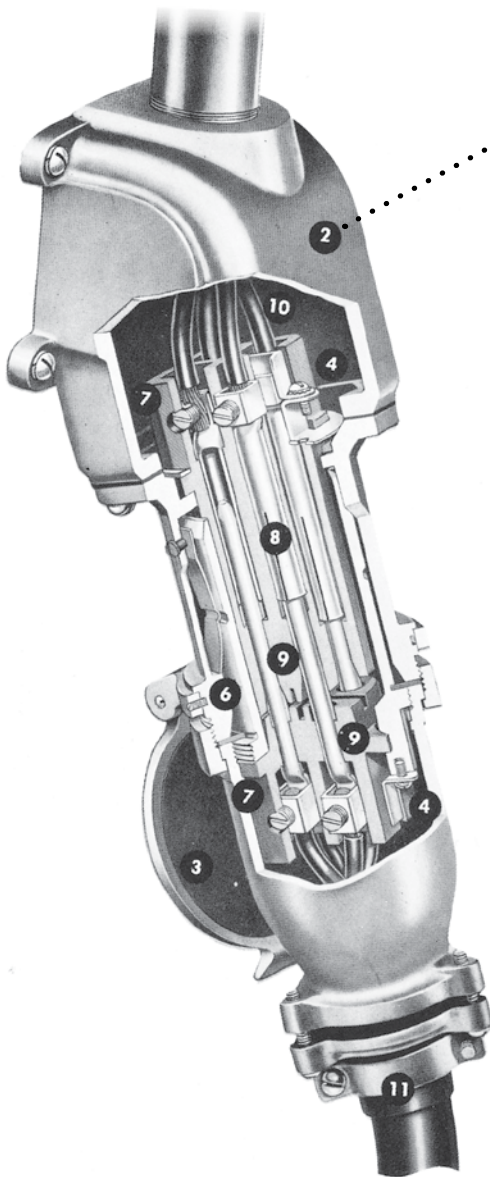

1. Circuit-interrupting rated safety
2. Cast aluminum, corrosion-resistant copper-free alloy housings and enclosures provide lightweight and maximum corrosion resistance, along with electrostatic epoxy powder coat finish
3. Quick conversion between weathertight flap cover and watertight screw cap assemblies. Basic receptacle housing accommodates both covers and is the basic component of all complete units. All watertight configured plugs may be used interchangeably
4. Two grounding arrangements (Style No. 1 and Style No. 2)
5. Four complete J-Lines: 30, 60, 100 and 200 amps; 600VAC/250VDC (plus 150A/270A specials)
6. Flap cover can be rotated and locked in any convenient position
7. Pressure-type solderless wiring terminals
8. Silver-plated contacts
9. One-piece interior assemblies interchangeable from regular to reverse service in the field with a screwdriver
10. Wiring space ample for maximum requirements
11. Cable clamps adjustable for maximum range of cable size. Oil-resistant Neoprene strain-relief bushing compresses around cable tightly, prevents entry of dust and moisture
12. Polarization provides positive non-interchangeability for different electrical systems
13. Reversed contacts flexibility: male–female reversed installation within any housing

J-Line™ Interconnection Systems

Polarization

Devices offer standard and custom polarization for total operator safety so that plugs will fit only into receptacles or connectors having the same electrical/specification characteristics.

Visual means of aligning units for a specific, positive polarization are provided:

- Button inside of receptacle housing mates to groove on plug shroud
- Smaller primary guides also assist positive part-part mating
- External I.D. of 1 of 8 polarization indexes visible
- Different polarizations assigned to voltages can't mate — a safer system!



Conversion to Weathertight and Watertight Types



*Weathertight J-Line™
with flap cover assembly*



*Watertight J-Line™
with screw cap*

Substitution of either the flap cover assembly or the screw cap assembly on the housing of the basic receptacle permits quick and easy conversion between the weathertight and watertight types. Only a small screwdriver is needed to change in the field.

The basic receptacle housing is constructed with a threaded end to accommodate a screw cap or the collar nut of a watertight plug. A special groove above the threads accommodates the flap cover assembly. The flap cover assembly may be rotated around this grooved shell and the set-screw locked in any convenient position.

The watertight plug, with its collar screwed firmly to the basic receptacle shell, forms a completely watertight connection on either type of receptacle assembly.

These conversion features also permit the use of flap cover or screw cap on connector housings.

J-Line™ Interconnection Systems

30–200/270 Amp (30–200A Load Breaking), Maximum 600VAC/250VDC
Load-Breaking Receptacles, Plugs, Connectors and Inlets

Power & High Voltage — Russellstoll® Pin & Sleeve Power Connectors

For all Weathertight and Watertight types.

Reversed Contacts Service

All J-Line™ plugs, receptacles and connectors can be furnished for Reverse Service — male (plug) interiors in the receptacles and female (receptacle) interiors in the plugs. When ordering reverse service, add a final suffix “R” to the complete catalog number. Price on request.

Example: JRFA334HR

J-Line™ receptacle and plug interior assemblies of the same amperage may be quickly interchanged from regular to reverse service (or vice versa) in the field. A screwdriver is the only tool required.

Example: Panel-mounted low-profile receptacles with male interiors act as male inlets in remote equipment; receive power from female plugs. (Cup cap also recommended.)

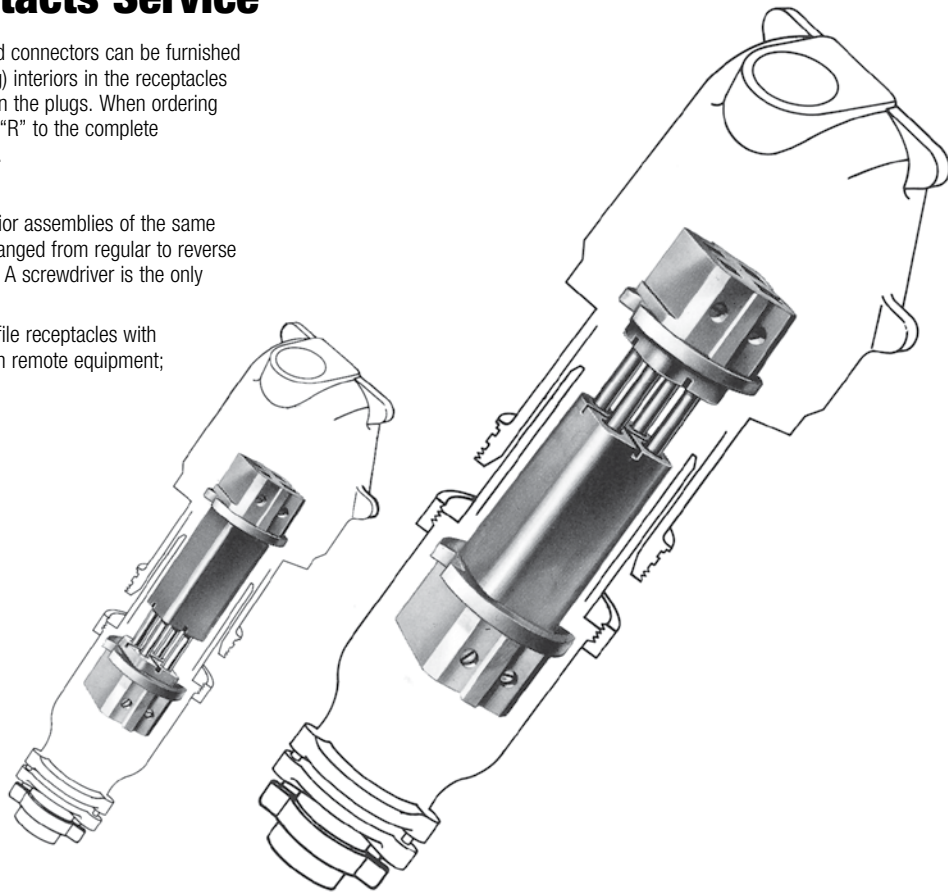

Regular Service

Interior assemblies placed in normal, standard positions — female interior assembly is positioned in the receptacle housing and the male interior assembly is positioned in the plug housing.

Reversed Service

Note the complete interior assemblies have now been interchanged so that the male (plug) interior assembly is positioned in the receptacle housing and the female (receptacle) interior assembly is positioned in the plug housing.

J-Line™ Interconnection Systems

30–200/270 Amp (30–200A Load-Breaking), Maximum 600VAC/250VDC
Load-Breaking Receptacles, Plugs, Connectors and Inlets

Grounding Data

Effective grounding of portable electrical equipment is necessary to protect operators from electric shock. The National Electrical Code® requires that in most cases, exposed non-current-carrying metal parts of portable equipment shall be grounded if operated at more than 150 volts to ground. Grounding must be used in other than residential occupancies when used in damp or wet locations, or by persons standing on the ground or on metal floors or working inside of metal tanks or boilers, except where supplied through an insulating transformer with ungrounded secondary of not over 50 volts.

Plugs and receptacles provide for grounding of portable equipment in either of two ways:

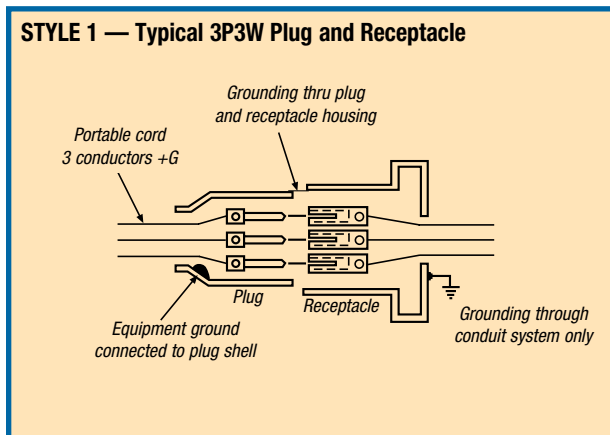

Style 1

4P4W (or 3P3W) through Metal Housings of Plug and Receptacle

In this system shown **above**, the equipment grounding conductor in the flexible cable is electrically connected directly to the plug or cable connector housing by a suitable terminal. The receptacle is grounded by being part of a grounded conduit system.

When inserted, the plug housing makes contact with the grounded receptacle or connector housing by means of the receptacle ground spring before the current-carrying contacts engage. On withdrawal, it remains in contact until after the current-carrying contacts disengage.

Corrosive Locations

The National Electrical Code® requires that under conditions favorable to corrosion, the grounding conductor for enclosures and equipment be of copper or other corrosion-resistant material. In alternating current systems, this necessitates running another conductor back to the common grounding electrode. This may be run through the conduit containing the circuit conductors. At the receptacle, this grounding conductor should be connected to the extra (grounding) pole by the pressure connector provided for that purpose. Where such an extra grounding conductor is required, Style 2 receptacles should be used.

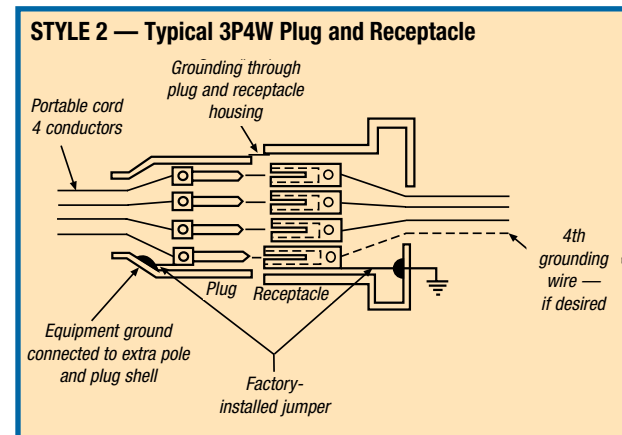

Style 2

3P4W (or 2P3W) through a Separate Grounding Pole in Plug and Receptacle

In this system shown **above**, the equipment grounding conductor in the flexible cable is electrically connected to the equipment grounding pole in the plug or cable connector interior. The grounding pole of the receptacle interior is electrically connected by a spring-strap jumper to the receptacle housing, which itself is grounded by being part of the ground spring of the receptacle or connector housing as described in Style 1.

The grounding contact in a type 2 receptacle is longer than the current-carrying contacts so that the ground connection makes first and breaks last.

NEC and National Electrical Code are registered trademarks of the National Fire Protection Association, Inc.

J-Line™ Interconnection Systems

Connectors



Receptacles



	PANEL MOUNT	BASIC RECEPTACLE	STANDARD SERIES*
◆ □ ▼ JCF323H _ JCF333F JCF334H JCF344F	◆ □ ▼ JRF323H _ JRF333F JRF334H JRF344F	◆ □ ▼ JRF323H _ JRF333F JRF334H JRF344F	◆ □ ▼ JRFA323H _ JRFA333F JRFA334H JRFA344F
JCS323H JCS333F JCS334H JCS344F	JRSX323H JRSX333F JRSX334H JRSX344F	JRS323H JRS333F JRS334H JRS344F	JRSA323H JRSA333F JRSA334H JRSA344F
JCF623H JCF633F JCF634H JCF644F	JRF623H JRF633F JRF634H JRF644F	JRF623H JRF633F JRF634H JRF644F	JRFA623H JRFA633F JRFA634H JRFA644F
JCS623H JCS633F JCS634H JCS644F	JRSX623H JRSX633F JRSX634H JRSX644F	JRS623H JRS633F JRS634H JRS644F	JRSA623H JRSA633F JRSA634H JRSA644F
JCF1023H JCF1033F JCF1034H JCF1044F	JRF1023H JRF1033F JRF1034H JRF1044F	JRF1023H JRF1033F JRF1034H JRF1044F	JRFA1023H JRFA1033F JRFA1034H JRFA1044F
JCS1023H JCS1033F JCS1034H JCS1044F	JRSX1023H JRSX1033F JRSX1034H JRSX1044F	JRS1023H JRS1033F JRS1034H JRS1044F	JRSA1023H JRSA1033F JRSA1034H JRSA1044F
JCF2023H JCF2033F JCF2034H JCF2044F	JRF2023H JRF2033F JRF2034H JRF2044F	JRF2023H JRF2033F JRF2034H JRF2044F	JRFA2023H JRFA2033F JRFA2034H JRFA2044F
JCS2023H JCS2033F JCS2034H JCS2044F	JRSX2023H JRSX2033F JRSX2034H JRSX2044F	JRS2023H JRS2033F JRS2034H JRS2044F	JRSA2023H JRSA2033F JRSA2034H JRSA2044F

Conduit Size (Using JPA_ Series Conduit Adapters)

CURRENT RATING	STD. SIZE	MAX. SIZE
30	1"	1¼"
60	1½"	1½"
100	2"	2"
200	3"	3"

* Smaller NPT openings available on request.

Cable Conduit Adapters, see **page H-355**.

Conduit Entry Location: Standard Series

