

J-Line™ Interconnection Systems

J-Line™
4P4W Max.
30 through 200A

Robust service in metal for many industrial applications, the J-Line™ offers a value alternative to MaxGard® in 3P4W, 30–200 Amp applications with less severe needs. Unique among competitors, the J-Line™ uses a reversible contract carrier for maximum flexibility in many portable service applications.

Design Features

Russellstoll® J-Line™ Load-Breaking Plugs, Connectors and Receptacles

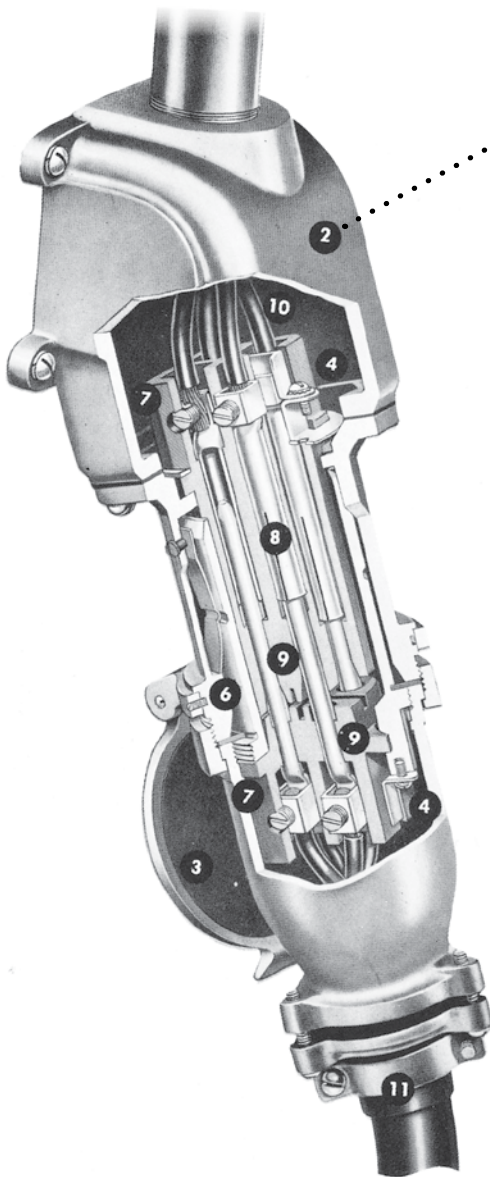

1. Circuit-interrupting rated safety
2. Cast aluminum, corrosion-resistant copper-free alloy housings and enclosures provide lightweight and maximum corrosion resistance, along with electrostatic epoxy powder coat finish
3. Quick conversion between weathertight flap cover and watertight screw cap assemblies. Basic receptacle housing accommodates both covers and is the basic component of all complete units. All watertight configured plugs may be used interchangeably
4. Two grounding arrangements (Style No. 1 and Style No. 2)
5. Four complete J-Lines: 30, 60, 100 and 200 amps; 600VAC/250VDC (plus 150A/270A specials)
6. Flap cover can be rotated and locked in any convenient position
7. Pressure-type solderless wiring terminals
8. Silver-plated contacts
9. One-piece interior assemblies interchangeable from regular to reverse service in the field with a screwdriver
10. Wiring space ample for maximum requirements
11. Cable clamps adjustable for maximum range of cable size. Oil-resistant Neoprene strain-relief bushing compresses around cable tightly, prevents entry of dust and moisture
12. Polarization provides positive non-interchangeability for different electrical systems
13. Reversed contacts flexibility: male–female reversed installation within any housing

J-Line™ Interconnection Systems

Polarization

Devices offer standard and custom polarization for total operator safety so that plugs will fit only into receptacles or connectors having the same electrical/specification characteristics.

Visual means of aligning units for a specific, positive polarization are provided:

- Button inside of receptacle housing mates to groove on plug shroud
- Smaller primary guides also assist positive part-part mating
- External I.D. of 1 of 8 polarization indexes visible
- Different polarizations assigned to voltages can't mate — a safer system!



Conversion to Weathertight and Watertight Types



*Weathertight J-Line™
with flap cover assembly*



*Watertight J-Line™
with screw cap*

Substitution of either the flap cover assembly or the screw cap assembly on the housing of the basic receptacle permits quick and easy conversion between the weathertight and watertight types. Only a small screwdriver is needed to change in the field.

The basic receptacle housing is constructed with a threaded end to accommodate a screw cap or the collar nut of a watertight plug. A special groove above the threads accommodates the flap cover assembly. The flap cover assembly may be rotated around this grooved shell and the set-screw locked in any convenient position.

The watertight plug, with its collar screwed firmly to the basic receptacle shell, forms a completely watertight connection on either type of receptacle assembly.

These conversion features also permit the use of flap cover or screw cap on connector housings.

J-Line™ Interconnection Systems

30–200/270 Amp (30–200A Load Breaking), Maximum 600VAC/250VDC
Load-Breaking Receptacles, Plugs, Connectors and Inlets

Power & High Voltage — Russellstoll® Pin & Sleeve Power Connectors

For all Weathertight and Watertight types.

Reversed Contacts Service

All J-Line™ plugs, receptacles and connectors can be furnished for Reverse Service — male (plug) interiors in the receptacles and female (receptacle) interiors in the plugs. When ordering reverse service, add a final suffix “R” to the complete catalog number. Price on request.

Example: JRFA334HR

J-Line™ receptacle and plug interior assemblies of the same amperage may be quickly interchanged from regular to reverse service (or vice versa) in the field. A screwdriver is the only tool required.

Example: Panel-mounted low-profile receptacles with male interiors act as male inlets in remote equipment; receive power from female plugs. (Cup cap also recommended.)

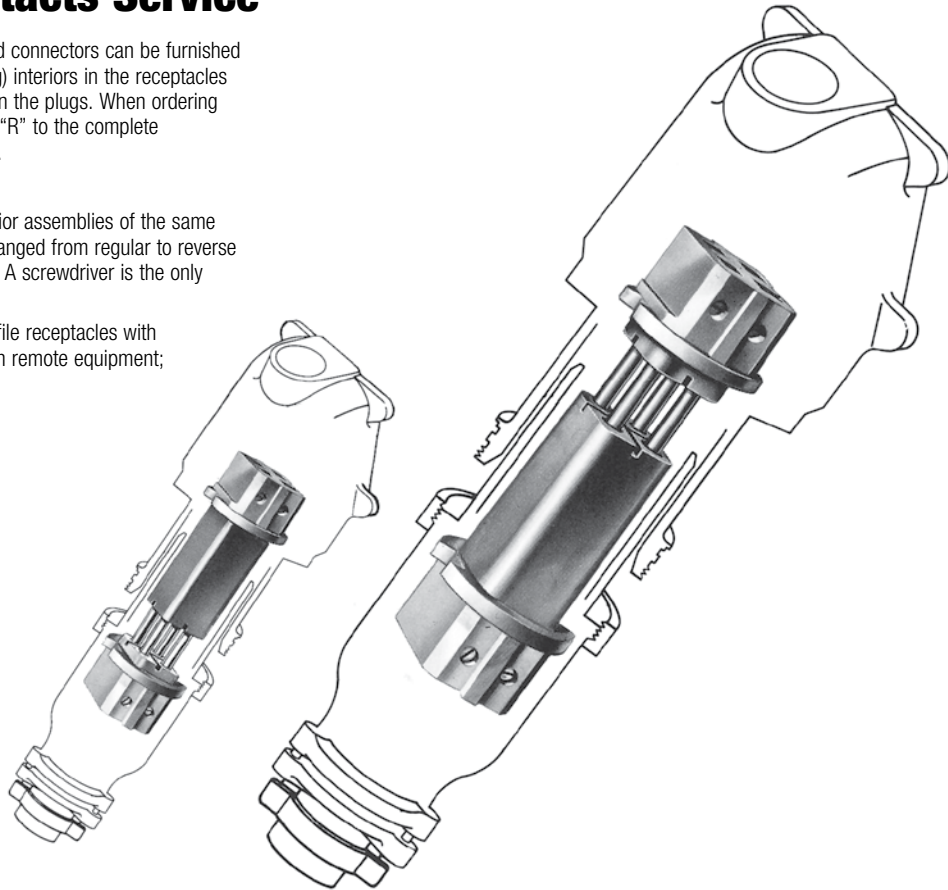

Regular Service

Interior assemblies placed in normal, standard positions — female interior assembly is positioned in the receptacle housing and the male interior assembly is positioned in the plug housing.

Reversed Service

Note the complete interior assemblies have now been interchanged so that the male (plug) interior assembly is positioned in the receptacle housing and the female (receptacle) interior assembly is positioned in the plug housing.

J-Line™ Interconnection Systems

30–200/270 Amp (30–200A Load-Breaking), Maximum 600VAC/250VDC
Load-Breaking Receptacles, Plugs, Connectors and Inlets

Grounding Data

Effective grounding of portable electrical equipment is necessary to protect operators from electric shock. The National Electrical Code® requires that in most cases, exposed non-current-carrying metal parts of portable equipment shall be grounded if operated at more than 150 volts to ground. Grounding must be used in other than residential occupancies when used in damp or wet locations, or by persons standing on the ground or on metal floors or working inside of metal tanks or boilers, except where supplied through an insulating transformer with ungrounded secondary of not over 50 volts.

Plugs and receptacles provide for grounding of portable equipment in either of two ways:

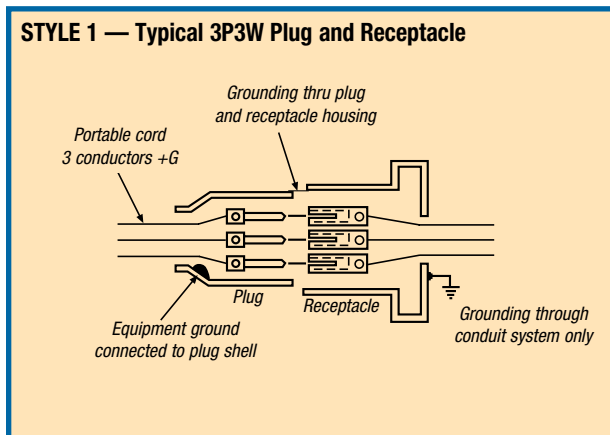

Style 1

4P4W (or 3P3W) through Metal Housings of Plug and Receptacle

In this system shown **above**, the equipment grounding conductor in the flexible cable is electrically connected directly to the plug or cable connector housing by a suitable terminal. The receptacle is grounded by being part of a grounded conduit system.

When inserted, the plug housing makes contact with the grounded receptacle or connector housing by means of the receptacle ground spring before the current-carrying contacts engage. On withdrawal, it remains in contact until after the current-carrying contacts disengage.

Corrosive Locations

The National Electrical Code® requires that under conditions favorable to corrosion, the grounding conductor for enclosures and equipment be of copper or other corrosion-resistant material. In alternating current systems, this necessitates running another conductor back to the common grounding electrode. This may be run through the conduit containing the circuit conductors. At the receptacle, this grounding conductor should be connected to the extra (grounding) pole by the pressure connector provided for that purpose. Where such an extra grounding conductor is required, Style 2 receptacles should be used.

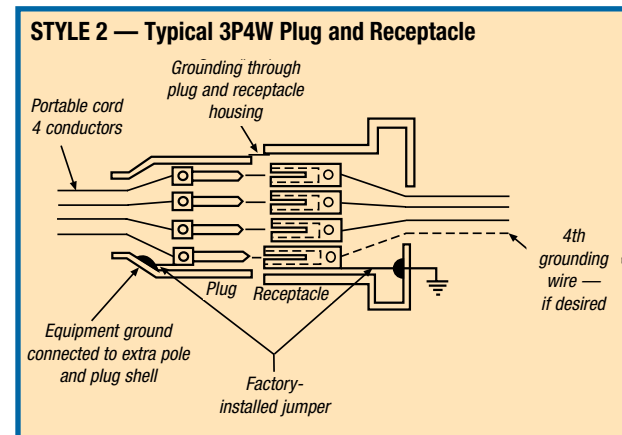

Style 2

3P4W (or 2P3W) through a Separate Grounding Pole in Plug and Receptacle

In this system shown **above**, the equipment grounding conductor in the flexible cable is electrically connected to the equipment grounding pole in the plug or cable connector interior. The grounding pole of the receptacle interior is electrically connected by a spring-strap jumper to the receptacle housing, which itself is grounded by being part of the ground spring of the receptacle or connector housing as described in Style 1.

The grounding contact in a type 2 receptacle is longer than the current-carrying contacts so that the ground connection makes first and breaks last.

NEC and National Electrical Code are registered trademarks of the National Fire Protection Association, Inc.

J-Line™ Interconnection Systems

30–270 Amp (30, 60, 100 and 200 Amp Load-Breaking, 150 and 270 Amp Special Service), Maximum 600VAC/250VDC Receptacles, Plugs, Connectors and Inlets

Plugs



(All plugs come with watertight screw collar)

Max. 600VAC/250VDC

CURRENT RATING	WEATHERTIGHT/WATERTIGHT	CONFIGURATION	
30 Amp	Weathertight (Spring Hinged Flap Cover)	2P3W	JPS323H ▾
		3P3W*	JPS333F
	Watertight (Screw Cover)	3P4W	JPS334H
		4P4W*	JPS344F
60 Amp	Weathertight (Spring Hinged Flap Cover)	2P3W	JPS623H
		3P3W*	JPS633F
	Watertight (Screw Cover)	3P4W	JPS634H
		4P4W*	JPS644F
100 Amp (150 Amp)**	Weathertight (Spring Hinged Flap Cover)	2P3W	JPS1023H
		3P3W*	JPS1033F
	Watertight (Screw Cover)	3P4W	JPS1034H
		4P4W*	JPS1044F
200 Amp (270 Amp)**	Weathertight (Spring Hinged Flap Cover)	2P3W	JPS2023H
		3P3W*	JPS2033F
	Watertight (Screw Cover)	3P4W	JPS2034H
		4P4W*	JPS2044F

* Housing Ground Only (Style 1 Grounding), see [page H-347](#).

+ Shown with 20° angle adapter. Can be furnished with 45° angle at same price. When ordering, add suffix -45 to catalog number.

** Special rated devices (not shown). Consult Customer Service for details.

Note: To order Reverse Service, add a final suffix "R" to catalog number.
Example: JRFA334HR — a receptacle housing with male interior.

□ Polarization index (std. shown); consult Technical Services for more information.

◆ Flap Cover "F" noted. Screw Cover "S" also available.

▼ For Reversed Contacts, use "R" suffix to any catalog number.

Std. Cable Bushing

CURRENT RATING	BUSHING I.D.	MAX. AWG SIZE
30	7/8"	#6 7-strand or #8 flexible
60	1 1/16"	#4 7-strand or flexible
100	1 1/2"	#10 19-strand or #1 flexible
200	2"	4/0 19-strand or flexible

(See [page H-354](#) for other bushings.)