



Device Boxes, Covers & Accessories

T&B Catalog Number:

2CCB

UPC Number:

04226935045

Status:

Active

Description:

Two Gang Weatherproof Receptacle Cover, Silver, Aluminum, Blank, Device Mount

General

Material	Stamped Aluminum
Color	Silver
Mounting	Device Mount
Number of Gangs	Two

Packaging

T&B Inner Pack	10
Package in Units	50
T&B Sold in UOM	Each
T&B Weight Per UOM	0.13 lbs. Each

Application Support

T&B Instruction Sheets	ta04883-tb2
D-Pak Merchandising System	Available on Website
Industry Cross Reference	Available on Website

Notes

Rain tight when used with appropriate Red Dot covers.

Certifications



File Nbr:

E 28688

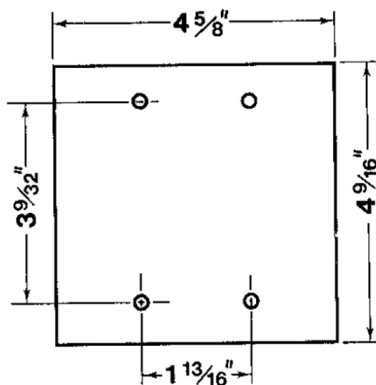
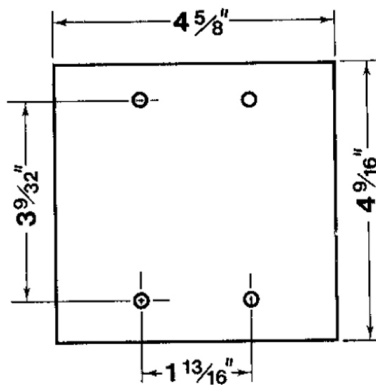

For further technical assistance, please contact us...

Thomas & Betts - USA
8155 T&B Blvd.
Memphis, TN 38125
www.tnb.com

T&B Technical Support
MS 3B-50
8155 T&B Blvd.
Memphis, TN 38125

Hours: 7AM - 6PM CDT
Monday-Friday
Phone: (888) 862-3289
Fax: (901) 252-1321
Email:techsupport@tnb.com