

DATE	REV	ECN	APP'D. BY
1-13-15	A4	10188	TRM
3-8-16	A5	10594	TRM

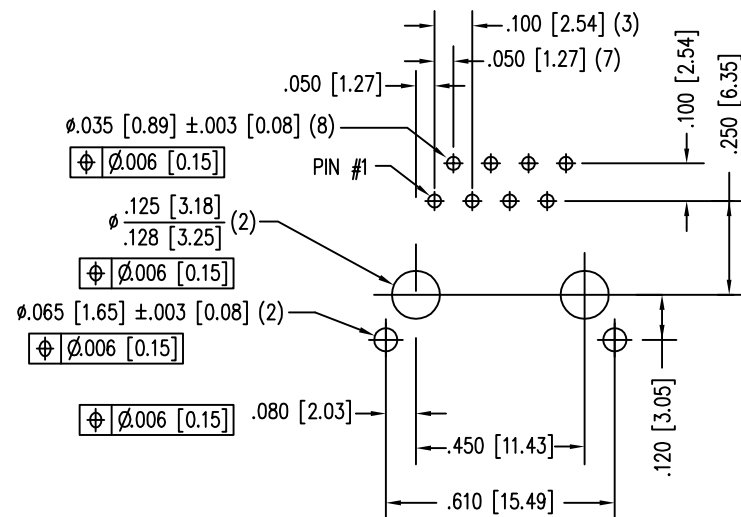
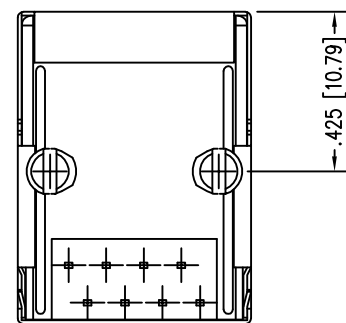
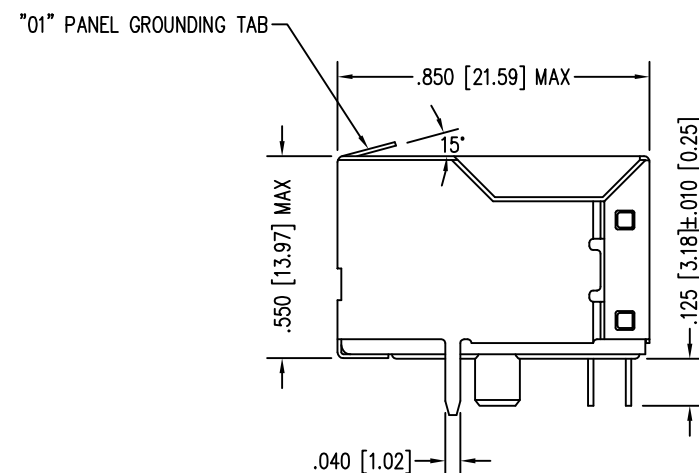
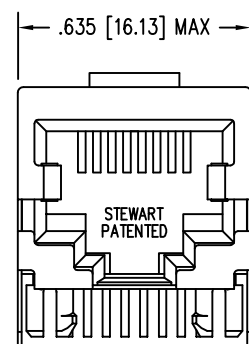
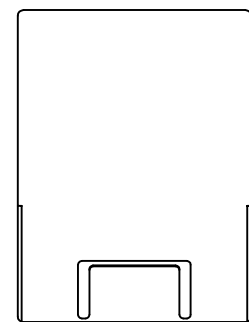

P.C.B. RECOMMENDED HOLE LAYOUT
SEEN FROM COMPONENT SIDE
ALL CENTERLINE DIMENSIONS ARE BASIC.

NOTES:

- CONNECTOR MATERIALS:
HOUSING: THERMOPLASTIC UL94 V-0
CONTACTS/SHIELD: COPPER ALLOY
SHIELD PLATING: NICKEL OR "REFLOW" TIN
CONTACT PLATING: SELECTIVE GOLD IN CONTACT AREA
SEE CHART FOR PART NUMBER
- FOR PRODUCT SPECIFICATIONS SEE PR022-01.
- RATED AT MAX. 260°C FOR MAX. 10 SECS.
- DIMENSIONS AND TOLERANCES COMPLY WITH TIA-1096 STANDARD.

50 MICRO-INCHES [1.27um]	SS64800-077F
30 MICRO-INCHES [0.76um]	SS64800-035F
CONTACT PLATING IN MATING AREA	PART NUMBER

THIRD ANGLE PROJECTION

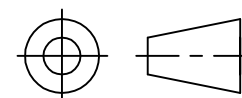

1118 Susquehanna Trail South
Glen Rock, PA 17327-9199
(717) 235-7512

<http://www.stewartconnector.com>

DO NOT SCALE DRAWING
DRAWING IS SUBJECT TO
CHANGE WITHOUT NOTICE

TITLE: EIGHT CONTACT, EIGHT POSITION, SHIELDED JACK, NON-FLANGED
ALTERNATE SOLDER TAIL POSITION, TOP PANEL GROUND AT 15°

DIMENSIONS: INCHES [METRIC]
UNLESS OTHERWISE SPECIFIED
TOLERANCES ARE ±.005 [0.13]
ANGLES ARE ± 1°

THIS DRAWING AND THE SUBJECT MATTER SHOWN THEREON
ARE CONFIDENTIAL AND THE PROPRIETARY PROPERTY OF
STEWART CONNECTOR AND SHALL NOT BE REPRODUCED,
COPIED, OR USED IN ANY MANNER WITHOUT PRIOR WRITTEN
CONSENT OF STEWART CONNECTOR. ONE OR MORE U.S. PATENTS
MAY APPLY TO THIS PRODUCT. FOR DETAILS, PLEASE
VISIT: [HTTP://BELFUSE.COM/STEWART/STEWART_PATENTS/](http://BELFUSE.COM/STEWART/STEWART_PATENTS/)

DRN BY:	RVO	DATE	04-08-05
APPD BY:	RGC	DATE	04-11-05
DWG NO.	CT640095F	REV.	A5

SHEET NO. 1 OF 1

