



Main

Range of product	Harmony XAC
Product or component type	Pendant control station
Device short name	XACB

Complementary

Control station type	Double insulated
Enclosure material	Glass reinforced polyester
Electrical circuit type	Power circuit Control circuit
Enclosure type	Empty enclosure
Number of cut-out	2 cut-outs
Control station colour	Yellow
Cable entry	Rubber sleeve with stepped entry 7...13 mm
Guard rail	Without
Vertical operator cut-out centre	40 mm
Standards	CSA C22.2 No 14 EN/IEC 60947-5-1
Product certifications	CSA type 4
Protective treatment	TH
Ambient air temperature for operation	-25...70 °C
Ambient air temperature for storage	-40...70 °C
Vibration resistance	15 gn (f= 10...500 Hz) conforming to IEC 60068-2-6
Shock resistance	100 gn conforming to IEC 60068-2-27
Overvoltage category	Class II conforming to IEC 61140
IP degree of protection	IP65 conforming to IEC 60529
IK degree of protection	IK08 conforming to EN 50102
Mechanical durability	1000000 cycles
Net weight	0.76 kg

Packing Units

Unit Type of Package 1	PCE
Number of Units in Package 1	1
Package 1 Height	11.5 cm
Package 1 Width	10.5 cm
Package 1 Length	26.5 cm
Package 1 Weight	625.0 g
Unit Type of Package 2	S04
Number of Units in Package 2	12
Package 2 Height	30.0 cm
Package 2 Width	40.0 cm

Package 2 Length	60.0 cm
Package 2 Weight	8.285 kg

Offer Sustainability

REACH Regulation	REACH Declaration
REACH free of SVHC	Yes
EU RoHS Directive	Pro-active compliance (Product out of EU RoHS legal scope) EU RoHS Declaration
Toxic heavy metal free	Yes
Mercury free	Yes
China RoHS Regulation	China RoHS Declaration
RoHS exemption information	Yes

Contractual warranty

Warranty	18 months
----------	-----------

Dimensions

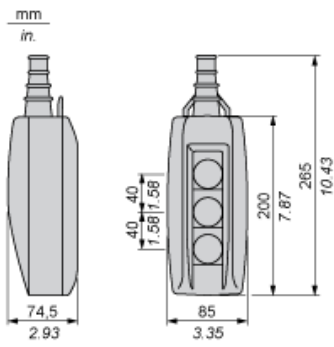

Protective cable sleeves

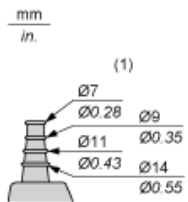

(1) Internal \emptyset

Control of Single-Speed Reversing Motor

With XESD1181 contact block, to be ordered separately

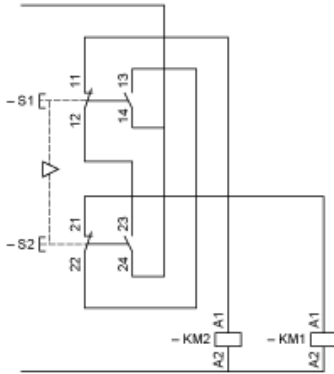

Control of 2-Speed Reversing Motor

With XESD1281 contact block, to be ordered separately

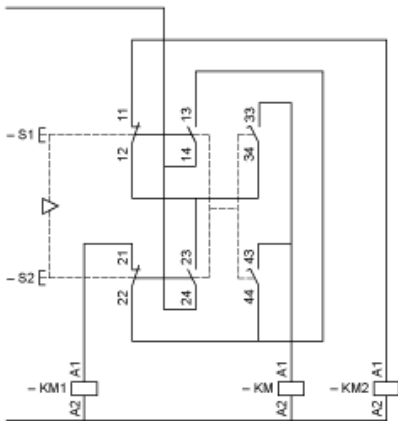

KM High speed contactor

Control of Single-Speed Reversing Motor 2-Phase Switching

With XESD1191 contact block, to be ordered separately

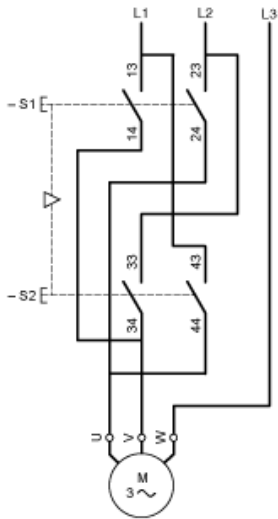

Combined with 3-pole isolating block XACS399 or XACS3991, shown in the unoperated position (pendant station "supplied"), fitted with key release trigger action latching Emergency stop operator.

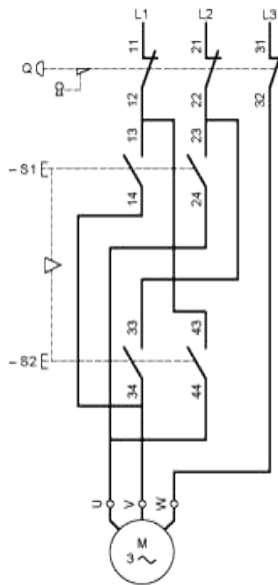

Control of 2-Speed Reversing Motor 2-Phase Switching

With XESD1291 contact block, to be ordered separately

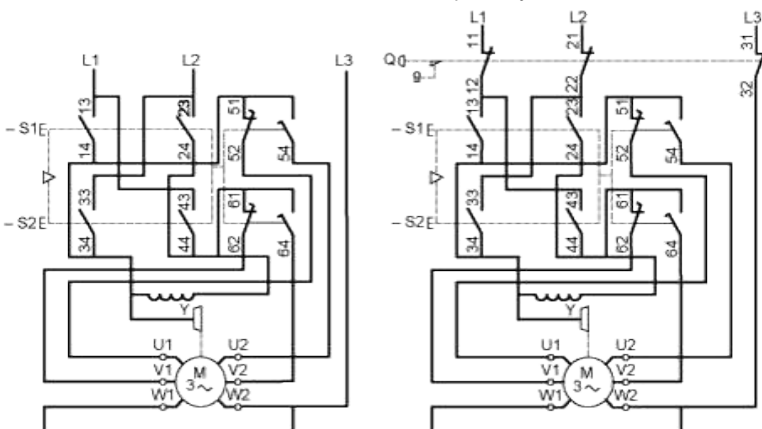

Control of Single-Speed Reversing Motor 3-Phase switching, Reversing by 2-Phase Inversion

With XESD2201 contact block, to be ordered separately

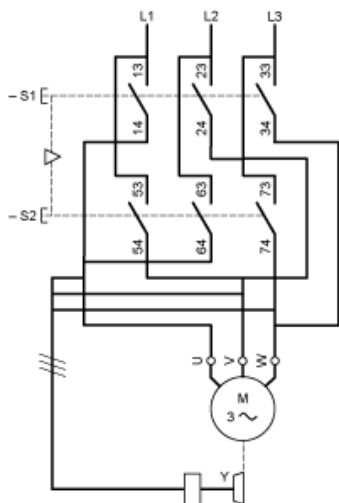

Control of Single-Speed Reversing Motor 3-Phase switching, Reversing by 2-Phase Inversion

With XESD2241 contact block, to be ordered separately

