

Product data sheet

Specifications



discrete output module, Modicon TM3, 16 relay outputs, screw, 24V DC

TM3DQ16R

Product availability: Stock - Normally stocked in distribution facility

Main

Range of Product	Modicon TM3
Product or Component Type	Discrete output module
Range Compatibility	Modicon M241 Modicon M251 Modicon M221 Modicon M262
Discrete output type	Relay normally open
Discrete output number	16
Discrete output logic	Positive or negative
Discrete output voltage	240 V AC relay output 30 V DC relay output
Discrete output current	2000 mA relay output

Complementary

Discrete I/O number	16
Current consumption	0 mA 24 V DC via bus connector at state off) 75 mA 24 V DC via bus connector at state on)
Response time	10 ms (turn-on) 5 ms (turn-off)
Mechanical durability	20000000 cycles
Minimum load	10 mA 5 V DC relay output
Local signalling	1 LED per channel (green) for output status
Electrical connection	10 x 1.5 mm ² removable screw terminal block with pitch 3.81 mm adjustment for outputs
Maximum cable distance between devices	Unshielded cable <98.4 ft (30 m) relay output
Insulation	Between output and internal logic 2300 V AC Between outputs 750 V AC Between output groups 1500 V AC
Marking	CE
Mounting support	Top hat type TH35-15 rail IEC 60715 Top hat type TH35-7.5 rail IEC 60715 plate or panel with fixing kit
Height	3.5 in (90 mm)
Depth	3.3 in (84.6 mm)
Width	1.08 in (27.4 mm)
Net Weight	0.320 lb(US) (0.145 kg)

Price is "List Price" and may be subject to a trade discount – check with your local distributor or retailer for actual price.

Environment

Standards	IEC 61131-2
Product Certifications	cULus CE UKCA RCM EAC cULus HazLoc
Resistance to electrostatic discharge	8 kV in air IEC 61000-4-2 4 kV on contact IEC 61000-4-2
Resistance to electromagnetic fields	9.1 V/m (10 V/m) 80 MHz...1 GHz IEC 61000-4-3 2.7 V/m (3 V/m) 1.4 GHz...2 GHz IEC 61000-4-3 0.9 V/m (1 V/m) 2 GHz...3 GHz IEC 61000-4-3
Resistance to magnetic fields	98.4 A/m (30 A/m) 50/60 Hz IEC 61000-4-8
Resistance to fast transients	2 kV relay output IEC 61000-4-4
Surge withstand	1 kV I/O common mode IEC 61000-4-5 DC
Resistance to conducted disturbances	10 V 0.15...80 MHz IEC 61000-4-6 3 V spot frequency (2, 3, 4, 6.2, 8.2, 12.6, 16.5, 18.8, 22, 25 MHz) Marine specification (LR, ABS, DNV, GL)
Electromagnetic emission	Radiated emissions 40 dB μ V/m QP class A 10 m)30...230 MHz IEC 55011 Radiated emissions 47 dB μ V/m QP class A 10 m)230...1000 MHz IEC 55011
Ambient Air Temperature for Operation	14...95 °F (-10...35 °C) vertical installation 14...131 °F (-10...55 °C) horizontal installation
Ambient Air Temperature for Storage	-13...158 °F (-25...70 °C)
Relative humidity	10...95 %, without condensation in operation) 10...95 %, without condensation in storage)
IP degree of protection	IP20 with protective cover in place
pollution degree	2
Operating altitude	0...6561.68 ft (0...2000 m)
Storage altitude	0...9842.5 ft (0...3000 m)
Vibration resistance	3.5 mm 5...8.4 Hz DIN rail 3 gn 8.4...150 Hz DIN rail 3.5 mm 5...8.4 Hz panel 3 gn 8.4...150 Hz panel
Shock resistance	15 gn 11 ms

Ordering and shipping details

Category	US10MSX22533
Discount Schedule	0MSX
GTIN	3606480611445
Returnability	Yes
Country of origin	CN

Packing Units

Unit Type of Package 1	PCE
Number of Units in Package 1	1
Package 1 Height	2.92 in (7.426 cm)
Package 1 Width	4.14 in (10.516 cm)
Package 1 Length	4.95 in (12.583 cm)

Package 1 Weight	8.8 oz (248.9 g)
Unit Type of Package 2	S04
Number of Units in Package 2	42
Package 2 Height	11.81 in (30 cm)
Package 2 Width	15.75 in (40 cm)
Package 2 Length	23.62 in (60 cm)
Package 2 Weight	26.5 lb(US) (12.0 kg)
Unit Type of Package 3	P12
Number of Units in Package 3	504
Package 3 Height	29.53 in (75 cm)
Package 3 Width	47.24 in (120 cm)
Package 3 Length	31.50 in (80 cm)
Package 3 Weight	299.8 lb(US) (136 kg)

Environmental Data

Schneider Electric aims to achieve Net Zero status by 2050 through supply chain partnerships, lower impact materials, and circularity via our ongoing “Use Better, Use Longer, Use Again” campaign to extend product lifetimes and recyclability.

[Environmental Data explained >](#)

[How we assess product sustainability >](#)

Environmental footprint

Carbon footprint (kg CO2 eq, Total Life cycle) 86

Environmental Disclosure [Product Environmental Profile](#)

Use Better

Materials and Substances

Packaging made with recycled cardboard Yes

Packaging without single use plastic Yes

[EU RoHS Directive](#) Pro-active compliance (Product out of EU RoHS legal scope)

REACH Regulation [REACH Declaration](#)

California proposition 65 **WARNING:** This product can expose you to chemicals including: Lead and lead compounds, which is known to the State of California to cause cancer and birth defects or other reproductive harm. For more information go to www.P65Warnings.ca.gov

PVC free Yes

Use Again

Repack and remanufacture

Circularity Profile [End of Life Information](#)

Take-back No

WEEE  The product must be disposed on European Union markets following specific waste collection and never end up in rubbish bins.

Dimensions Drawings

Dimensions

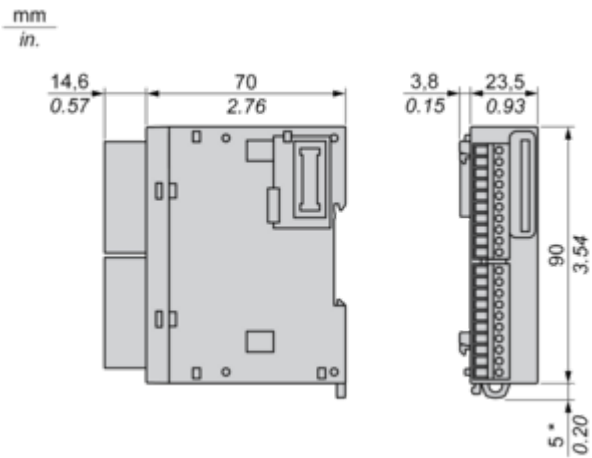

(*) 8.5 mm/0.33 in. when the clamp is pulled out.

Mounting and Clearance

Spacing Requirements

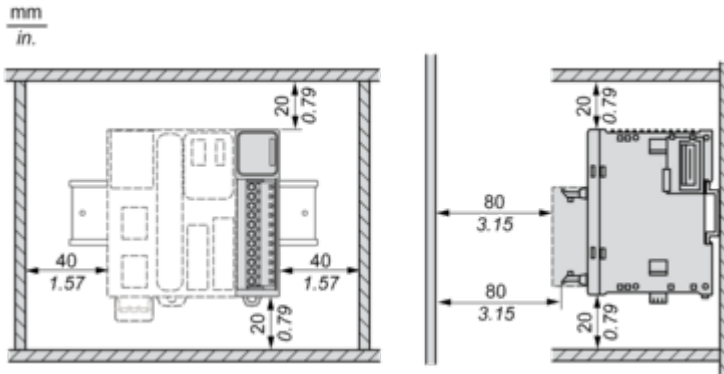

Mounting on a Rail

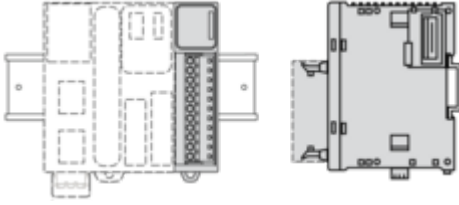

Incorrect Mounting

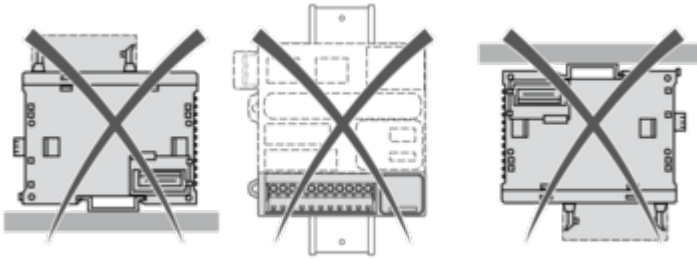

Mounting on a Panel Surface

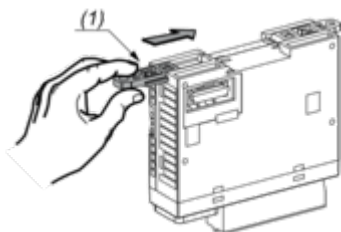

(1) Install a mounting strip

Mounting Hole Layout

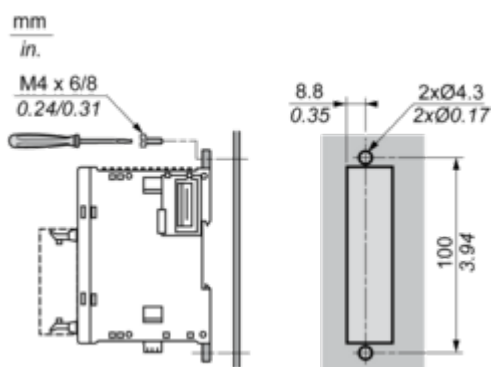

Connections and Schema

Digital Relay Output Module (16-channel)

Wiring Diagram (Positive Logic)

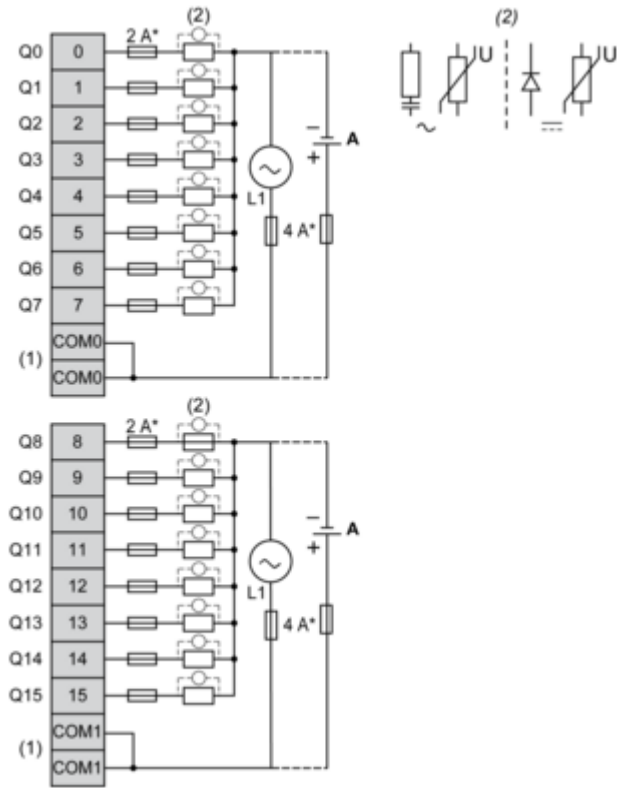

(*) Type T fuse

(1) The COM0 and COM1 terminals are **not** connected internally.

(2) To improve the life time of the contacts, and to protect from potential inductive load damage, it is recommended to connect a free wheeling diode in parallel to each inductive DC load or an RC snubber in parallel of each inductive AC load.

(A) Source wiring (positive logic).

Wiring Diagram (Negative Logic)

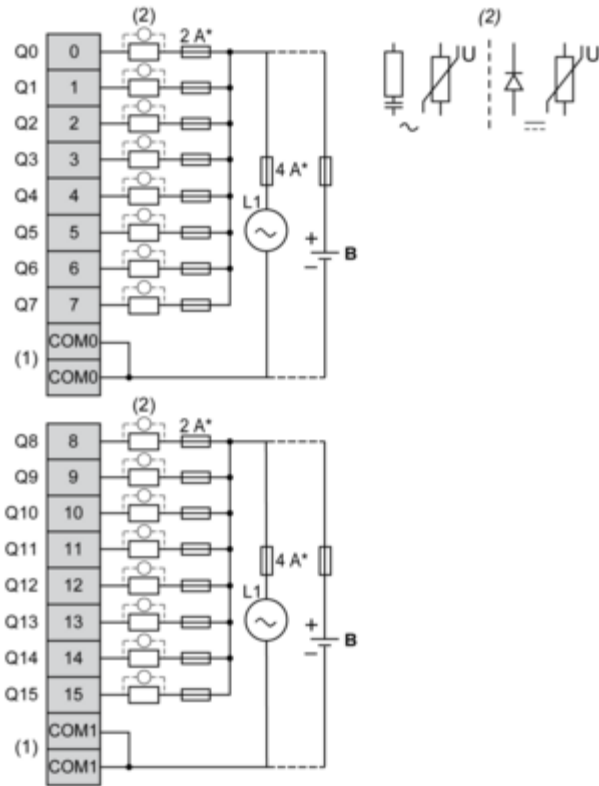

(*) Type T fuse

(1) The COM0 and COM1 terminals are **not** connected internally.

(2) To improve the life time of the contacts, and to protect from potential inductive load damage, it is recommended to connect a free wheeling diode in parallel to each inductive DC load or an RC snubber in parallel of each inductive AC load.

(B) Sink wiring (negative logic)