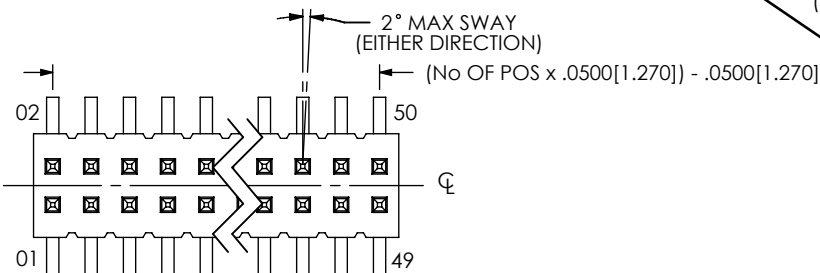
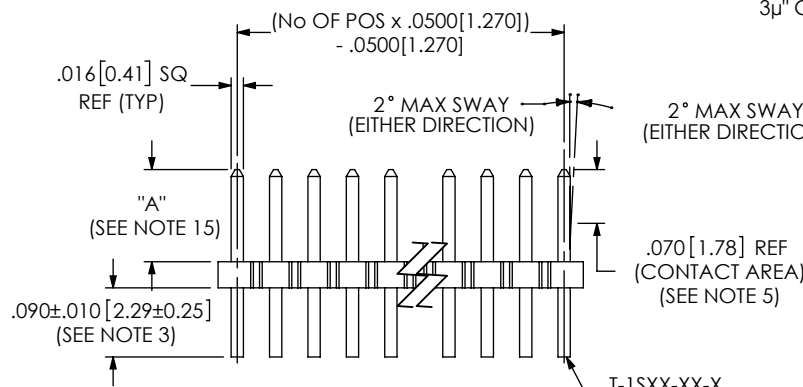
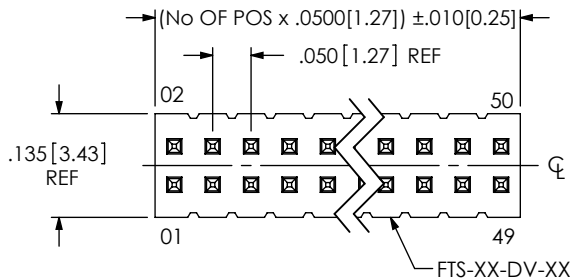


REVISION CI

TABLE 1			
LEAD STYLE	"A"	HAND FILL	BKT MACHINE
-01	0.120 [3.05]	T-1S40-04-XX-2	T-1S15-03-XXX
-02	0.075 [1.91]	T-1S15-03-XXX	T-1S15-03-XXX
-03	0.065 [1.65]	T-1S15-06-XXX	T-1S15-03-XXX
-04	0.150 [3.81]	T-1S15-03-XXX	T-1S15-03-XXX

DO NOT SCALE FROM THIS PRINT



MAY SUBSTITUTE ASP-61746-05-X FOR RETENTION PURPOSES FOR -DV STYLE ONLY

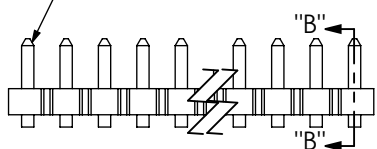


FIG 2 FTS-1XX-03-XX-DV SHOWN (DIFFERENT AS SHOWN, OTHERWISE SAME AS FIG 1)

SECTION "B"-B'

FTS-1XX-XX-XX-XX-XX-X-XX

No OF POSITIONS  
-02 THRU -50 (UNSHROUDED)  
-05 THRU -46 (SHROUDED)

LEAD STYLE  
SEE TABLE 1

PLATING SPECIFICATION

- L: 10μ" GOLD IN CONTACT AREA, MATTE TIN ON TAIL
- F: 3μ" GOLD IN CONTACT AREA, MATTE TIN ON TAIL
- S: 30μ" GOLD IN CONTACT AREA, MATTE TIN ON TAIL
- H: 30μ" GOLD IN CONTACT AREA, 3μ" GOLD ON TAIL
- SM: 30μ" GOLD IN CONTACT AREA, MATTE TIN ON TAIL
- LM: 10μ" GOLD IN CONTACT AREA, MATTE TIN ON TAIL
- FM: 3μ" GOLD IN CONTACT AREA, MATTE TIN ON TAIL
- G: 10μ" GOLD IN CONTACT AREA, 3μ" GOLD ON TAIL

PACKAGING

- BLANK: TUBES/BULK (SEE NOTE 14)
- TR: TAPE & REEL PACKAGING (SEE FIG 10, SHT 4) (SEE NOTE 19 & 20) (ONLY AVAILABLE WITH -DV OPTION)
- FR: FULL REEL QTY. TAPE & REEL (SEE NOTE 19 & 20) (ONLY AVAILABLE WITH -DV OPTION) (SEE FIG 10, SHT 4)

PICK & PLACE OPTION

- P: PICK AND PLACE PAD (USE PPP-25) (AVAILABLE ON POSITIONS 04 THRU 50) (SEE FIG 5, SHT 2 & FIG 7, SHT 3) (USE PPP-25-NT FOR TAPE & REEL)

OPTIONS

- S: END SHROUDS (SEE FIG 3, SHT 2 & FIG 6 SHT 3) (LEAD STYLE -02 & -03 ONLY) (05 POS MINIMUM, 46 POS MAXIMUM) (NOT AVAILABLE WITH -A OPTION; ORDER -SA FOR ALIGNMENT PIN WITH SHROUD) (SEE NOTES 6 & 7)
- SA: END SHROUDS W/ ALIGNMENT PINS (SEE FIG 4, SHT 2 & FIG 8, SHT 3) (LEAD STYLE -02 & -03 ONLY) (05 POS MINIMUM, 46 POS MAXIMUM) (SEE NOTES 6 & 7)
- A: MOLDED ALIGNMENT PIN (USE FTS-XX-DV-XX) (ONLY AVAILABLE IN -DV OPTION, 5 POS MINIMUM) (SEE FIG 9, SHT 3) (NOT AVAILABLE WITH -S OPTION; ORDER -SA FOR ALIGNMENT PIN AND SHROUD)

TAIL OPTION

- D: DOUBLE ROW THROUGH HOLE
- DV: DOUBLE ROW VERTICAL SURFACE MOUNT

NOTES:

1. Ⓢ REPRESENTS A CRITICAL DIMENSION.
2. PARTS MAY BE CUT TO POSITION.
3. SHEAR TAILS TO DIMENSION SHOWN.
4. MEASURED AT BEND RADIUS, NOT AT END OF PIN.
5. GOLD PLATING TO BE ON POST, TIN PLATING TO BE ON TAIL.
6. 4 POSITIONS PER ROW WILL BE COVERED BY SHROUDS. (2 POSITIONS PER ROW ON EACH END).
7. 4 POSITIONS MUST BE ADDED TO PART CALLOUT TO ALLOW FOR SHROUDS, EXAMPLE FTS-125-02-L-D-SA REQUIRES A 29 POSITION BODY.
8. NOTE DELETED.
9. MINIMUM PUSHOUT FORCE: .5 LB (8 OZ)
10. MAXIMUM CUT FLASH: .015 [0.38]
11. PPP-25-NT MUST BE USED FOR ALL TAPE AND REEL PACKAGING.
12. FILL BODY SO THAT THE LEAD IN OF THE CORE IS ON THE TAILS SIDE FOR -DV OPTION ONLY.
13. MAXIMUM BURR ALLOWANCE: .003 [0.08]
14. FOR PACKAGING OPTION LEFT BLANK, POSITIONS -05 THRU -50 TO BE TUBED, POSITIONS -02 THRU -04 ON TAIL OPTION -D TO BE LAYER PACKAGED.
15. MAX HEIGHT VARIATION BETWEEN ROWS: .005 [0.13].
16. NOTE DELETED
17. NOTE DELETED
18. ALL POSITIONS -2 THROUGH -4 FOR -DV MUST SHIP IN TAPE AND REEL WITH OR WITHOUT -XR IN THE CALLOUT
19. ORDERS WILL BE PACKAGED ACCORDING TO THE SAMTEC PACKAGING EFFICIENCY STANDARDS (SPES) FOUND ON WWW.SAMTEC.COM
20. ATTACH LABEL TO EACH REEL

FIG 1 FTS-1XX-01-XX-D SHOWN

UNLESS OTHERWISE SPECIFIED, DIMENSIONS ARE IN INCHES.

TOLERANCES ARE:  
DECIMALS ANGLES  
.XX: ±.01 [.3]  
.XXX: ±.005 [.13]  
.XXXX: ±.0020 [.051]

PROPRIETARY NOTE

THIS DOCUMENT CONTAINS CONFIDENTIAL AND PROPRIETARY INFORMATION AND ALL DESIGN, MANUFACTURING, REPRODUCTION, USE, PATENT RIGHTS AND SALES RIGHTS ARE EXPRESSLY RESERVED BY SAMTEC, INC. THIS DOCUMENT SHALL NOT BE DISCLOSED, IN WHOLE OR PART, TO ANY UNAUTHORIZED PERSON OR ENTITY NOR REPRODUCED, TRANSFERRED OR INCORPORATED IN ANY OTHER PROJECT IN ANY MANNER WITHOUT THE EXPRESS WRITTEN CONSENT OF SAMTEC, INC.



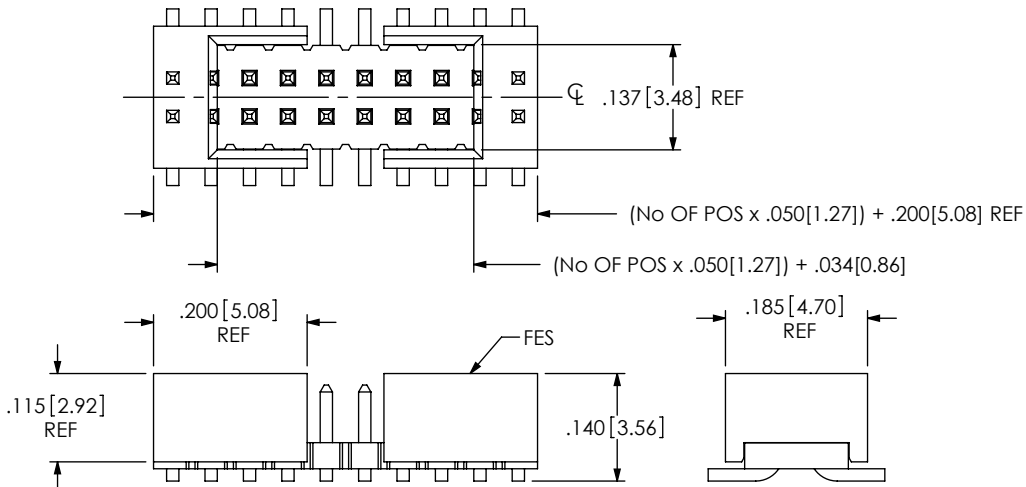
520 PARK EAST BLVD, NEW ALBANY, IN 47150  
PHONE: 812-944-6733 FAX: 812-948-5047  
e-Mail: info@SAMTEC.com code 55322

MATERIAL: DO NOT SCALE DRAWING SHEET SCALE: 4:1  
INSULATOR: LCP, UL 94 V0, COLOR: BLACK  
TERMINAL: PHOS BRONZE

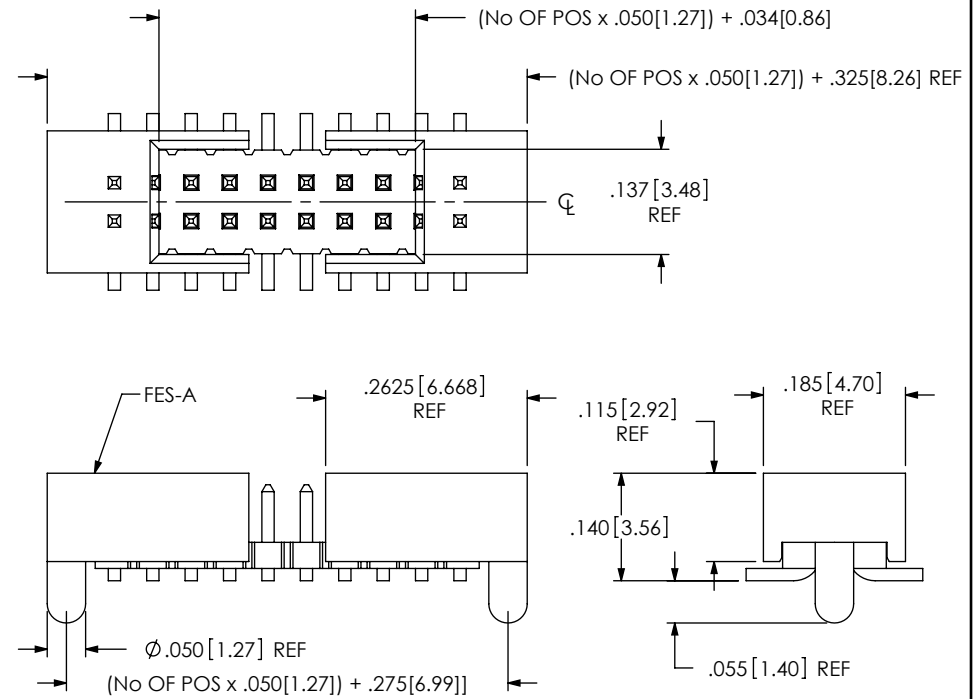
DESCRIPTION: .050 X .050 C.L. LOW PROFILE TERMINAL STRIP ASSEMBLY

DWG. NO. FTS-1XX-XX-XX-XX-XX-X-XX

BY: BRATCHER 11/29/1993 SHEET 1 OF 4

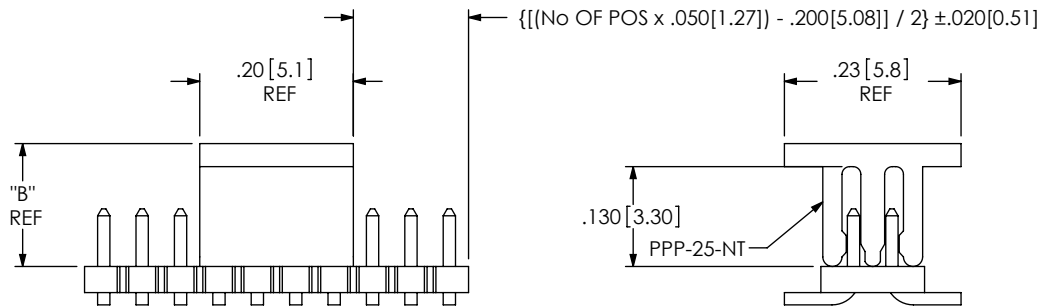


**FIG 3**  
 -DV-S OPTION (SEE NOTES 6 & 7)  
 FTS-106-02-XX-DV-S SHOWN  
 (DIFFERENT AS SHOWN, OTHERWISE SAME AS FIG 1)  
 NOTE: 4 POSITIONS MUST BE ADDED TO PART CALLOUT TO ACHIEVE DIMS  
 (NOT AVAILABLE WITH -A OPTION; ORDER -SA FOR ALIGNMENT PIN WITH SHROUD)

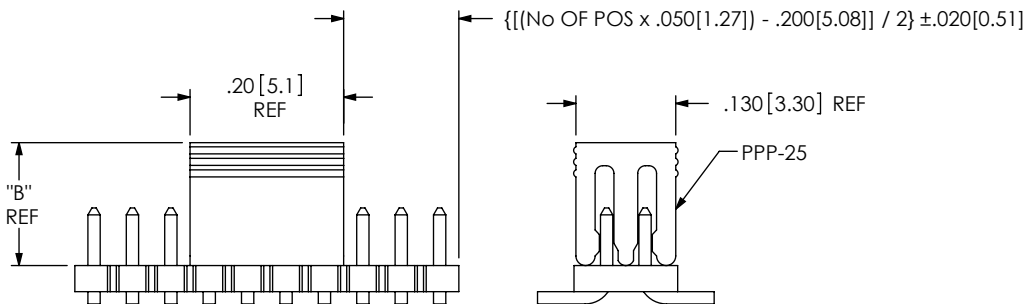


**FIG 4**  
 -DV-SA OPTION (SEE NOTES 6 & 7)  
 FTS-106-02-XX-DV-SA SHOWN  
 (DIFFERENT AS SHOWN, OTHERWISE SAME AS FIG 1)  
 NOTE: 4 POSITIONS MUST BE ADDED TO PART CALLOUT TO ACHIEVE DIMS

TABLE 3	
LEAD STYLE	"B"
-01, 02, 03	0.160 [4.06]
-04	0.180 [4.57]



(USE PPP-25-NT FOR TAPE AND REEL PACKAGING ONLY)



**FIG 5**  
 -DV-P OPTION  
 FTS-110-02-XX-DV-P SHOWN  
 (DIFFERENT AS SHOWN, OTHERWISE SAME AS FIG 1)

F:\DWG\MISC\MKTG\FTS-1XX-XX-XX-XX-X-XX-MKT.SLDDRW

**PROPRIETARY NOTE**  
 THIS DOCUMENT CONTAINS CONFIDENTIAL AND PROPRIETARY INFORMATION AND ALL DESIGN, MANUFACTURING, REPRODUCTION, USE, PATENT RIGHTS AND SALES RIGHTS ARE EXPRESSLY RESERVED BY SAMTEC, INC. THIS DOCUMENT SHALL NOT BE DISCLOSED, IN WHOLE OR PART, TO ANY UNAUTHORIZED PERSON OR ENTITY NOR REPRODUCED, TRANSFERRED OR INCORPORATED IN ANY OTHER PROJECT IN ANY MANNER WITHOUT THE EXPRESS WRITTEN CONSENT OF SAMTEC, INC.

DO NOT SCALE DRAWING

SHEET SCALE: 4:1

**samtec**

520 PARK EAST BLVD, NEW ALBANY, IN 47150  
 PHONE: 812-944-6733 FAX: 812-948-5047  
 e-Mail info@SAMTEC.com code 55322

DESCRIPTION: .050 X .050 C.L. LOW PROFILE  
 TERMINAL STRIP ASSEMBLY

DWG. NO.  
**FTS-1XX-XX-XX-XX-XX-X-XX**

BY: BRATCHER 11/29/1993 SHEET 2 OF 4

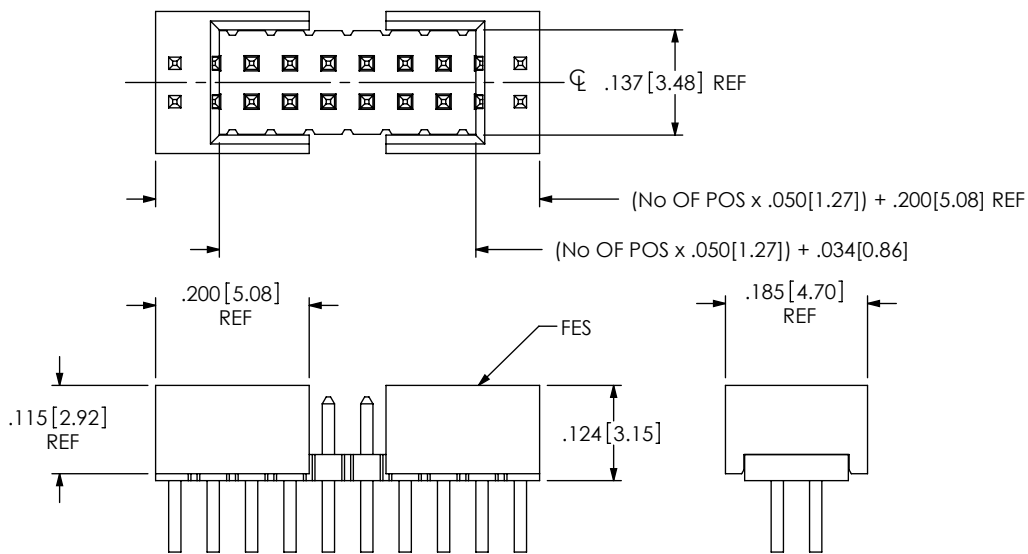


FIG 6

-D-S OPTION (SEE NOTES 6 & 7)  
FTS-106-02-XX-D-S SHOWN

(DIFFERENT AS SHOWN, OTHERWISE SAME AS FIG 1)

NOTE: 4 POSITIONS MUST BE ADDED TO PART CALLOUT TO ACHIEVE DIMS  
(NOT AVAILABLE WITH -A OPTION; ORDER -SA FOR ALIGNMENT PIN WITH SHROUD)

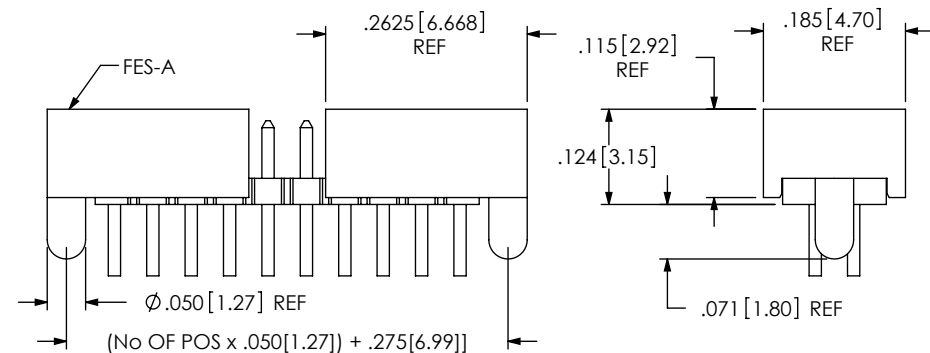
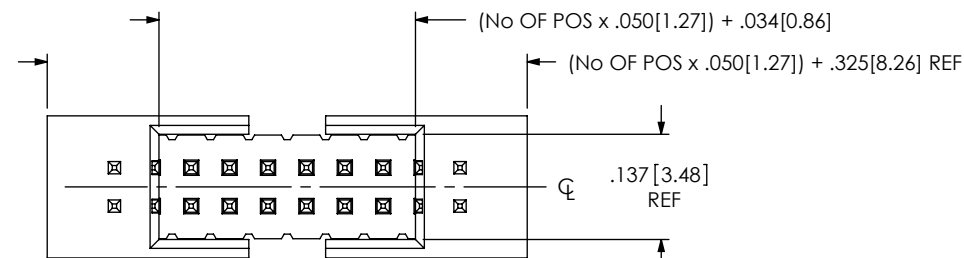


FIG 8

-D-SA OPTION (SEE NOTES 6 & 7)  
FTS-106-02-XX-D-SA SHOWN

(DIFFERENT AS SHOWN, OTHERWISE SAME AS FIG 1)

NOTE: 4 POSITIONS MUST BE ADDED TO PART CALLOUT TO ACHIEVE DIMS

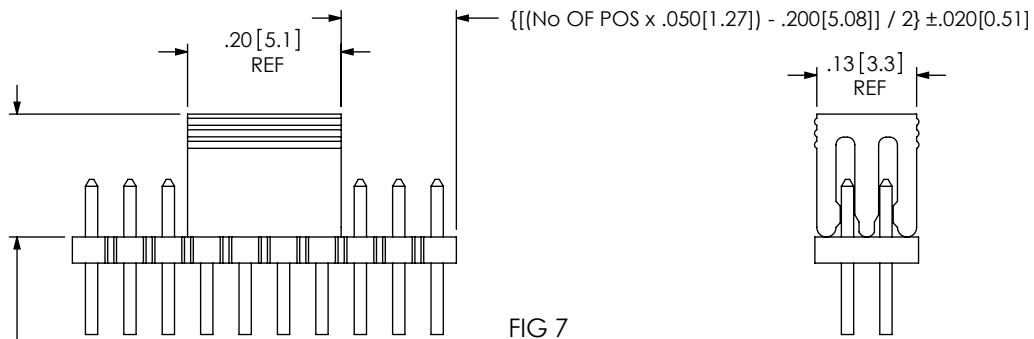


FIG 7

-D-P OPTION

FTS-110-02-XX-D-P SHOWN

(DIFFERENT AS SHOWN, OTHERWISE SAME AS FIG 1)

"B" REF  
(SEE TABLE 3, SHT 2)

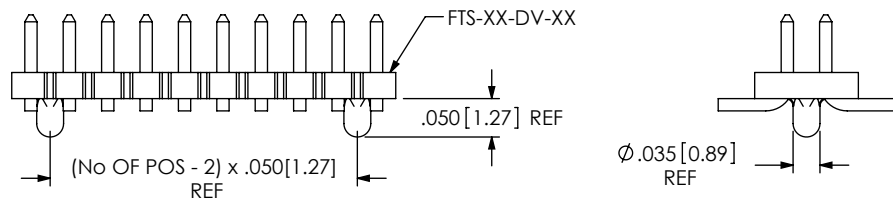


FIG 9

-A MOLDED ALIGNMENT PIN  
FTS-110-02-XX-DV-A SHOWN

(ONLY AVAILABLE IN -DV OPTION)

(DIFFERENT AS SHOWN, OTHERWISE SAME AS FIG 1)

PROPRIETARY NOTE

THIS DOCUMENT CONTAINS CONFIDENTIAL AND PROPRIETARY INFORMATION AND ALL DESIGN, MANUFACTURING, REPRODUCTION, USE, PATENT RIGHTS AND SALES RIGHTS ARE EXPRESSLY RESERVED BY SAMTEC, INC. THIS DOCUMENT SHALL NOT BE DISCLOSED, IN WHOLE OR PART, TO ANY UNAUTHORIZED PERSON OR ENTITY NOR REPRODUCED, TRANSFERRED OR INCORPORATED IN ANY OTHER PROJECT IN ANY MANNER WITHOUT THE EXPRESS WRITTEN CONSENT OF SAMTEC, INC.

DO NOT SCALE DRAWING

SHEET SCALE: 4:1

F:\DWG\MISC\MKTG\FTS-1XX-XX-XX-XX-XX-MKT.SLDDRW

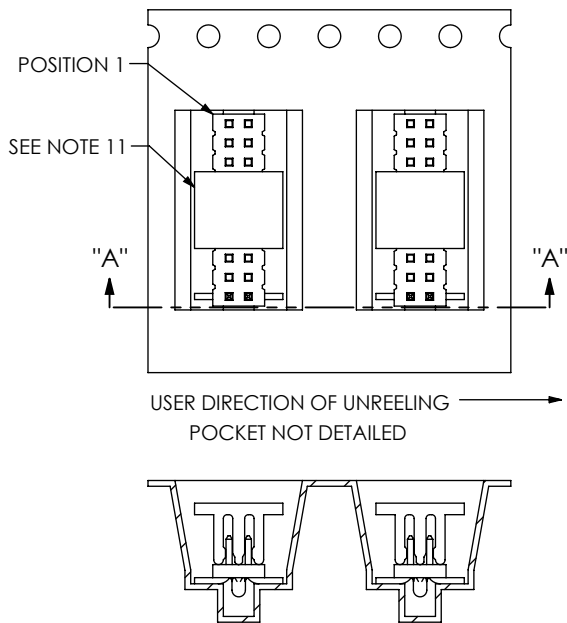


520 PARK EAST BLVD, NEW ALBANY, IN 47150  
PHONE: 812-944-6733 FAX: 812-948-5047  
e-Mail info@SAMTEC.com code 55322

DESCRIPTION: .050 X .050 C.L. LOW PROFILE  
TERMINAL STRIP ASSEMBLY

DWG. NO.  
FTS-1XX-XX-XX-XX-XX-X-XX

BY: BRATCHER 11/29/1993 SHEET 3 OF 4



SECTION "A"- "A"

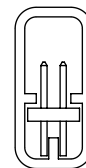
FIG 10

-TR: TAPE AND REEL PACKAGING WITH PPP-25-NT PAD  
NOT AVAILABLE ON THROUGH HOLE LEAD STYLES

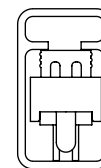
TABLE 2		
LEAD STYLE	PACKAGING TUBE	PLUG
-01/02/03/04-D	PT-FW001-D-.070-.198	TP-24
-DV, -D-P, -DV-P, -DV-A	PT-1-24-01-43	TP-24
-D-S(A)-P	PT-1-24-11-09	TP-24
-DV-S(A)-P	PT-1-24-01-09	TP-24
-D-S(A)	PT-1-24-01-37	TP-24-02
DV-S(A)	PT-1-24-02-36	TP-24-02

SEE NOTE 14

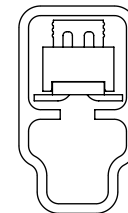
TUBE PACKAGING VIEW



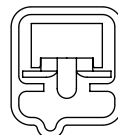
-01-D, -02-D, -03-D



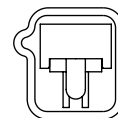
-D-S(A)-P



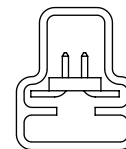
-DV-S(A)-P



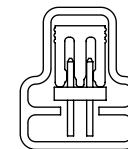
-DV-S(A)



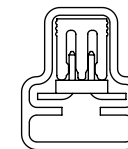
-D-S(A)



-DV



-D-P

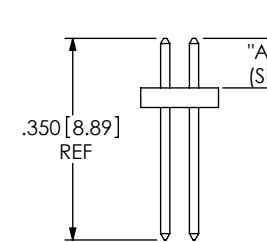


-DV-P

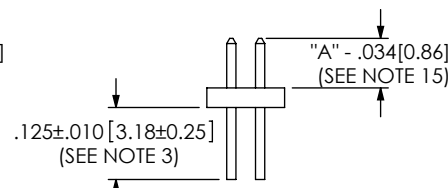
IN PROCESS VIEWS

(HANDFILL ONLY)

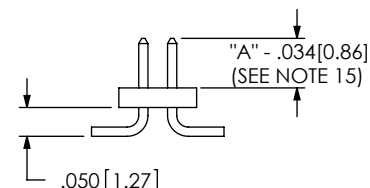
NOTE: -02 & -03 LEAD STYLES WITH -A PINS; BKT MACHINE ONLY



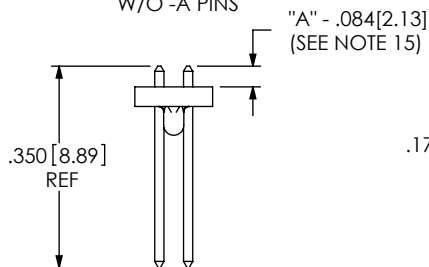
IN PROCESS 1  
W/O -A PINS



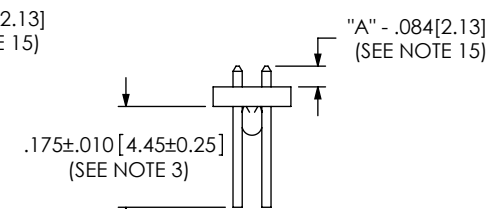
IN PROCESS 2  
W/O -A PINS



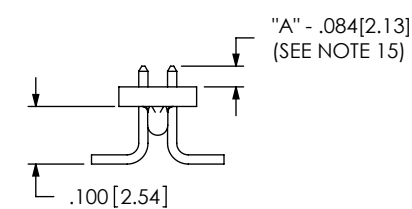
IN PROCESS 2  
W/O -A PINS



IN PROCESS 1  
WITH -A PINS



IN PROCESS 2  
WITH -A PINS



IN PROCESS 3  
WITH -A PINS

PROPRIETARY NOTE

THIS DOCUMENT CONTAINS CONFIDENTIAL AND PROPRIETARY INFORMATION AND ALL DESIGN, MANUFACTURING, REPRODUCTION, USE, PATENT RIGHTS AND SALES RIGHTS ARE EXPRESSLY RESERVED BY SAMTEC, INC. THIS DOCUMENT SHALL NOT BE DISCLOSED, IN WHOLE OR PART, TO ANY UNAUTHORIZED PERSON OR ENTITY NOR REPRODUCED, TRANSFERRED OR INCORPORATED IN ANY OTHER PROJECT IN ANY MANNER WITHOUT THE EXPRESS WRITTEN CONSENT OF SAMTEC, INC.

DO NOT SCALE DRAWING

SHEET SCALE: 2:1



520 PARK EAST BLVD, NEW ALBANY, IN 47150  
PHONE: 812-944-6733 FAX: 812-948-5047  
e-Mail info@SAMTEC.com code 55322

DESCRIPTION: .050 X .050 C.L. LOW PROFILE  
TERMINAL STRIP ASSEMBLY

DWG. NO.  
FTS-1XX-XX-XX-XX-XX-X-XX

BY: BRATCHER 11/29/1993 SHEET 4 OF 4