

POWER MANAGEMENT

Description

The SC2595 is an integrated linear DDR termination device, which provides a complete solution for DDR termination designs; while meeting the JEDEC requirements of SSTL-2 specifications for DDR-SDRAM termination.

The SC2595 can source and sink 1.5A current at the output V_{TT} while maintaining excellent load regulation.

V_{TT} is designed to track the V_{REF} voltage with a tight tolerance over the entire current range while preventing shoot through on the output stage.

A V_{SENSE} pin is incorporated to provide excellent load regulation, along with a buffered reference voltage.

The SC2595 incorporates a disable function built into the AV_{CC} pin to tri-state the output during Suspend To Ram (STR) states.

Features

- ◆ Regulates while sourcing or sinking 1.5A
- ◆ AV_{CC} range is from 2.5V to 5V
- ◆ Reference output
- ◆ Minimum number of external components
- ◆ Accurate internal voltage divider
- ◆ SOIC8-EDP package. Pb-free, Halogen free, and RoHS/WEEE compliant

Applications

- ◆ DDR memory termination
- ◆ High speed data line termination
- ◆ PC motherboards
- ◆ Graphics boards
- ◆ Disk drives
- ◆ CD-ROM drives

(Multiple patents pending.)

Typical Application Circuit

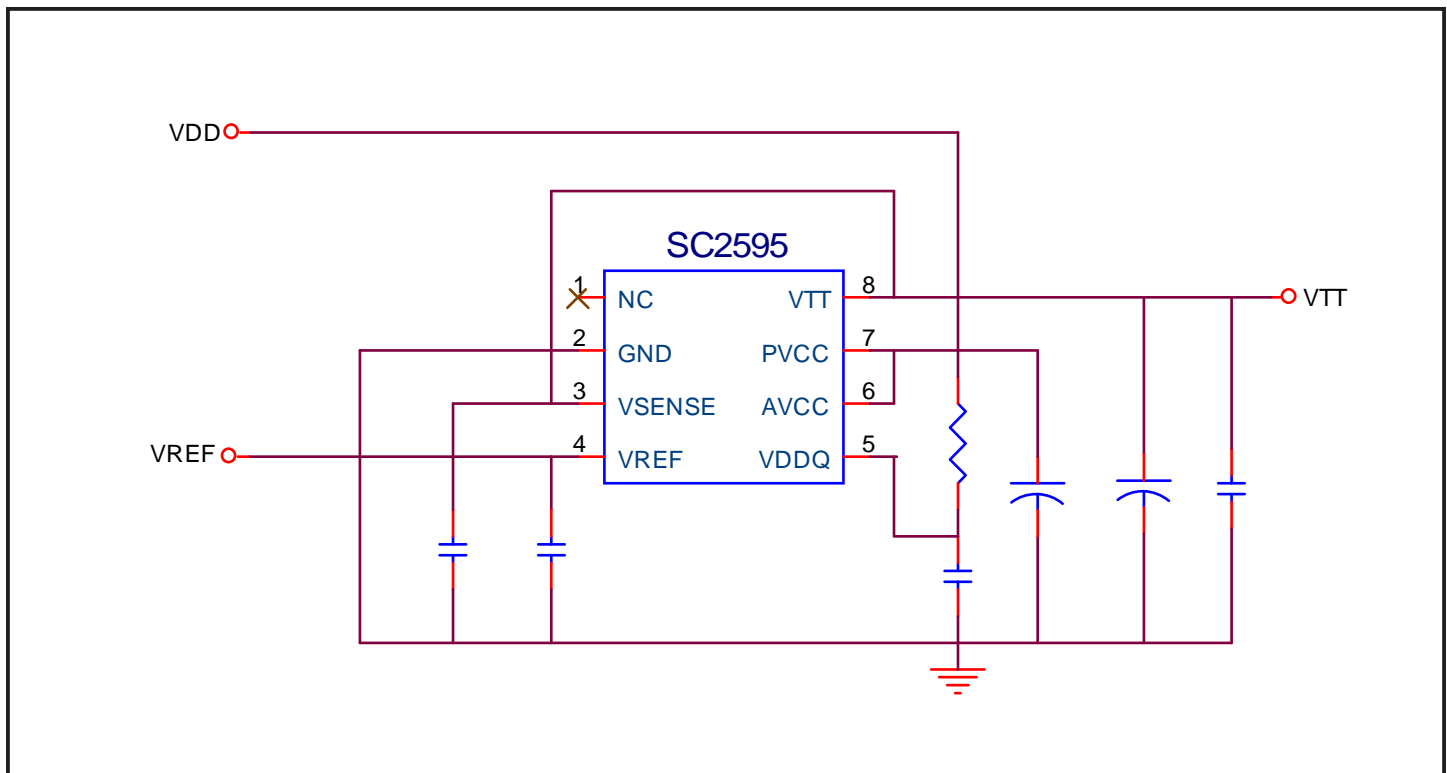

POWER MANAGEMENT
Absolute Maximum Ratings

Exceeding the specifications below may result in permanent damage to the device, or device malfunction. Operation outside of the parameters specified in the Electrical Characteristics section is not implied.

Parameter	Symbol	Maximum	Units
PVCC, AVCC, VDDQ to GND	V_{CC}	-0.3 to +6.0	V
Thermal Resistance Junction to Case SOIC8-EDP	θ_{JC}	5.5	°C/W
Thermal Resistance Junction to Ambient SOIC8-EDP	θ_{JA}	36.5	°C/W
Operating Temperature Range	T_A	-40 to +105	°C
Operating Junction Temperature Range	T_J	-40 to +150	°C
Storage Temperature Range	T_{STG}	-65 to +150	°C
Peak IR Reflow Temperature 10 - 40s	T_{LEAD}	240	°C
Peak IR Reflow Temperature 10 - 40s	T_{LEAD}	260	°C
ESD Rating (Human Body Model)	ESD	2	KV

Operating Range

Parameter	Symbol	Maximum	Units
Junction Temperature Range	T_J	-40 to +150	°C
AVCC to GND	AV_{CC}	2.3 to 5.5	V
PVCC to GND	PV_{CC}	2.3 to AV_{CC}	V

Electrical Characteristics

Specifications with standard typeface are for $T_J = 25^\circ\text{C}$ and limits in boldface type apply over the full Operating Temperature Range ($T_J = -40^\circ\text{C}$ to $+150^\circ\text{C}$). Unless otherwise specified, $AV_{CC} = PV_{CC} = 2.5\text{V}$, $V_{DDQ} = 2.5\text{V}$.

Parameter	Symbol	Test Conditions	Min	Typ	Max	Units
Reference Voltage	V_{REF}	$I_{REF_OUT} = 0\text{mA}$	$V_{DDQ}/2$ - 40mV	1.25	$V_{DDQ}/2$ + 40mV	V
Load Regulation ⁽¹⁾	REG_{LOAD}	$I_{LOAD} : 0$ to $+1.5\text{A}$ $I_{LOAD} : 0$ to -1.5A		-0.5 +0.5		%
VTT Output Voltage Offset	VOS_{VTT}	$I_{OUT} = 0\text{A}$, $V_{TT} - V_{REF}$	-20	0	+20	mV
Quiescent Current	I_Q	$I_{LOAD} = 0\text{A}$		400		µA
AVCC Enable Threshold				2.1		V
VDDQ Input Impedance	Z_{VDDQ}			100		kΩ

Note:

(1) For Load Regulation, use a 10ms current pulse width when measuring V_{TT} .

POWER MANAGEMENT

Pin Configuration

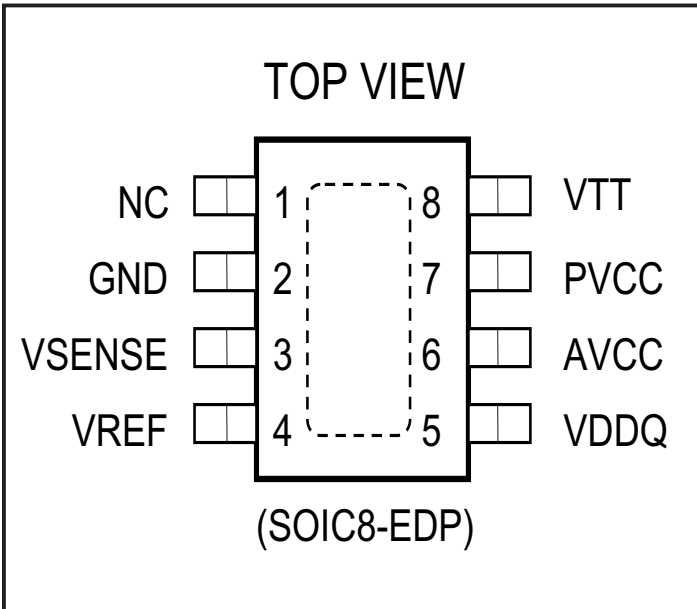

Ordering Information

Part Number	Package	Temp. Range (T _A)
SC2595STRT ⁽¹⁾⁽²⁾	SOIC8-EDP	-40 to +105°C
SC2595EVB	Evaluation Board	

Notes:

- (1) Only available in tape and reel packaging. A reel contains 2500 devices for SOIC8-EDP package.
- (2) Pb-free, Halogen free, and RoHS and WEEE compliant.

POWER MANAGEMENT
Pin Descriptions

SOIC-8L EDP Pin #	Pin Name	Pin Function
1	NC	No internal connection. ⁽¹⁾
2	GND	Ground.
3	VSENSE	<p>V_{SENSE} is a feedback pin. V_{TT} plane is always a narrow and long strip plane in most motherboard applications. This long strip plane will cause a large trace inductance and trace resistance. Consider the load transient condition; a fast load current going through V_{TT} strip plane can create voltage spikes on the V_{TT} plane. The load current can also cause a DC voltage drop on the V_{TT} plane. It is recommended that V_{SENSE} should be connected to the center of V_{TT} plane to improve the load regulation and the noise immunity. In case that one can't connect the V_{SENSE} pin to the center of the V_{TT} plane, one should connect it to the SC2595 V_{TT} pin directly. A longer trace of V_{SENSE} may pick up noise and cause the error of load regulation; hence the longer trace must be avoided.</p> <p>A 10nF to 100nF ceramic capacitor close to the V_{SENSE} pin is required to avoid oscillation during transient condition.</p>
4	VREF	<p>V_{REF} is an output pin, which provides the buffered output of the internal reference voltage. System designer can use the V_{REF} output voltage for Northbridge chipset and memory. Because these input pins are typically high impedance, there should be a small amount of current drawn from the V_{REF} pin [figure 9, 10]. To improve the noise immunity, a ceramic capacitor (10nF - 100nF) should be added from the V_{REF} pin to ground with short distance.</p>
5	VDDQ ⁽²⁾	<p>The V_{DDQ} pin is an input for creating internal reference voltage to regulate V_{TT}. The V_{DDQ} voltage is connected to internal 100Kohm resistor divider. The central tap of resistor divider ($V_{DDQ}/2$) is connected to the internal voltage buffer, which output is connected to V_{REF} pin and the non-inverting input of the error amplifier as the reference voltage. With the feedback loop closed, the V_{TT} output voltage will always track the $V_{DDQ}/2$ precisely. It is recommended to use 5.1 ohm + a 1uF ceramic capacitor for V_{DDQ} pin's filter to increase the noise immunity.</p>
6	AVCC ⁽²⁾	<p>The AV_{CC} pin is used to supply all of the internal control circuitry. AV_{CC} voltage has to be greater than its UVLO threshold voltage (2.1V typical) to allow the SC2595 be in normal operation. If AV_{CC} voltage is lower than the UVLO threshold voltage, the V_{TT} output voltage will remain at 0V.</p>
7	PVCC ⁽²⁾	<p>The PV_{CC} pin provides the rail voltage from where the V_{TT} pin draws load current. There is a limitation between AV_{CC} and PV_{CC}. The PV_{CC} voltage must be less or equal to AV_{CC} voltage to ensure the correct output voltage regulation. The V_{TT} source current capability is dependent on PV_{CC} voltage. Higher the voltage on PV_{CC}, higher the source current; however, it will cause more power loss and higher temperature rise [figure 5, 11, 12].</p>
8	VTT	<p>The V_{TT} pin is the output of SC2595. It can sink and source 1.5A continuous current and 3A peak current while keeping excellent load regulation. It is recommended that one should use at least 220uF low ESR capacitors (ESR should be lower than 250m ohm) and 10uF ceramic capacitors, which are uniformly spread on the V_{TT} strip plane to reduce the voltage spike under load transient condition.</p>
	Thermal Pad	Thermal pad should be connected to GND.

POWER MANAGEMENT

Notes:

- (1) Can be used for vias.
- (2) Power up of AV_{CC} , PV_{CC} and V_{DDQ} supplies.
 - (a) The preferred mode of operation is when the AV_{CC} , PV_{CC} and V_{DDQ} pins are tied together to a single supply.
 - (b) If and when AV_{CC} , PV_{CC} pins are tied to a supply separate to that of the V_{DDQ} supply pin; then the V_{DDQ} supply should lead AV_{CC} , PV_{CC} supply or the V_{DDQ} supply and the AV_{CC} , PV_{CC} supply should rise simultaneously.
 - (c) If the AV_{CC} , PV_{CC} and V_{DDQ} supply pins are connected in a way such that, AV_{CC} , PV_{CC} supplies precedes V_{DDQ} supply; then V_{TT} output precedes V_{DDQ} . This can cause the SDRAM device to latch-up, which may cause permanent damage to the SDRAM.

Block Diagram

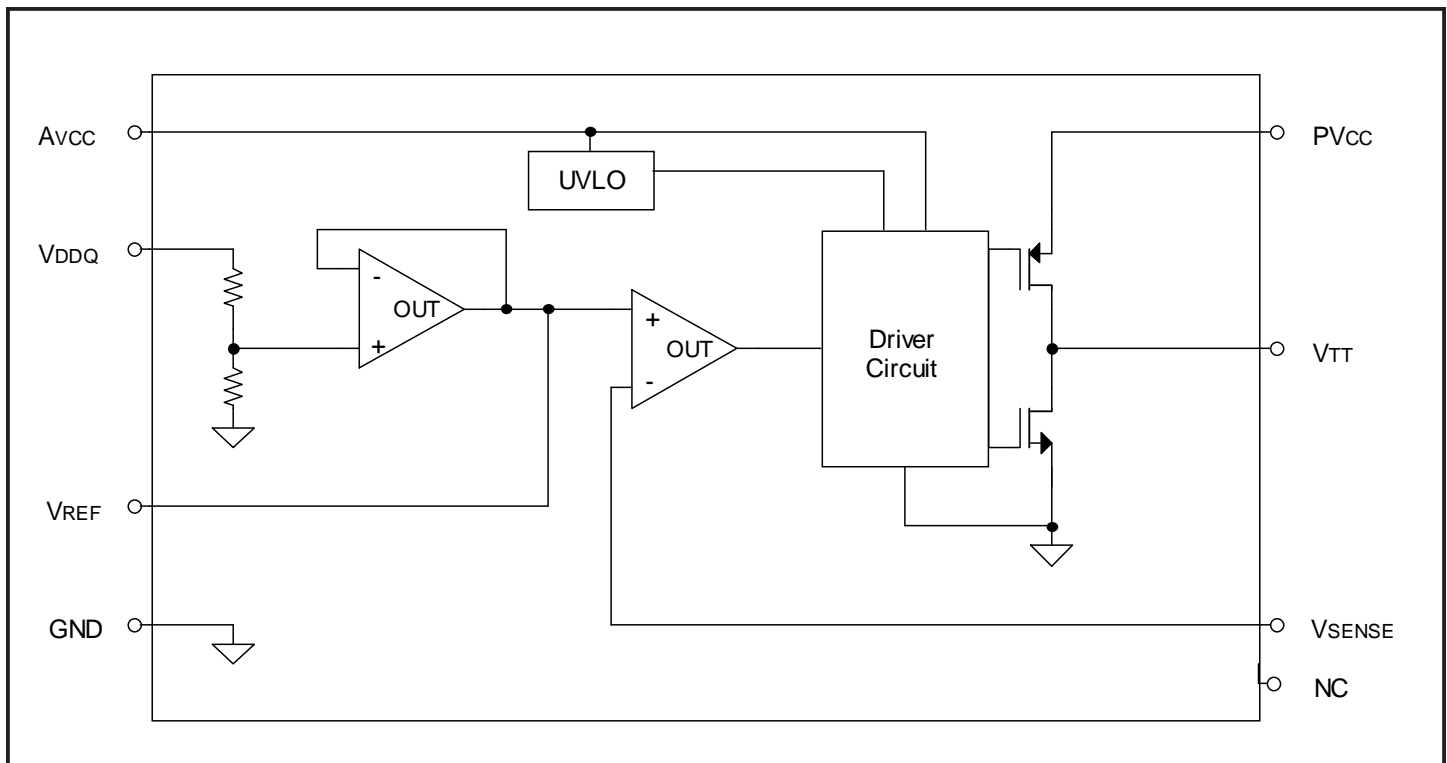

POWER MANAGEMENT

Application Information

Overview

Double Data Rate (DDR) SDRAM was defined by JEDEC 1997. Its clock speed is the same as previous SDRAM but data transfers speed is twice than previous SDRAM. By now, the requirement voltage range is changed from 3.3V to 2.5V; the power dissipation is smaller than SDRAM. For above reasons, it is very popular and widely used in M/B, N/B, Video-cards, CD ROM drives, Disk drives.

Regarding the DDR power management solution, there are two topologies can be selected for system designers. One is switching mode regulator that has bigger sink/source current capability, but the cost is higher and the board space needed is bigger. Another solution is linear mode regulator, which costs less, and needs the less board space. For two DIMM motherboards, system designers usually choose the linear mode for DDR power management solution.

Typical Application Circuits & Waveforms

Two different application circuits are shown below in Figure 1 to Figure 2. Each circuit is designed for specific condition. More details are described below. See Note 1. Below for recommended power up sequencing.

Application_1: Standard SSTL-2 Application

The AV_{CC} pins, the PV_{CC} pin, and the V_{DDQ} pin can be tied together for SSTL-2 application. It only needs a 2.5V power rail for normal operation. System designer can save the PCB space and reduce the cost. Please refer to figures 3 to 4 for test waveforms.

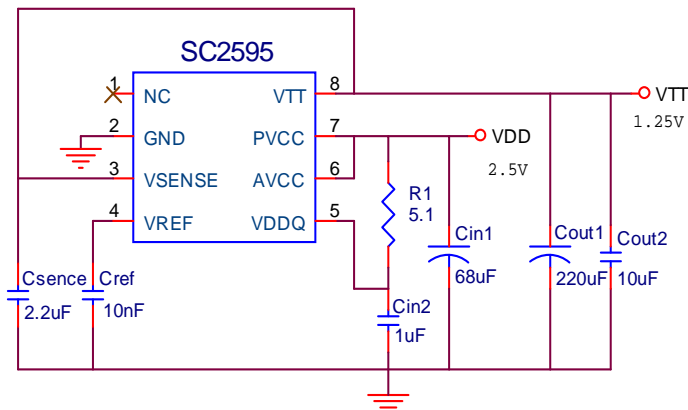

Figure 1: Standard SSTL-2 application

Application_2: Lower Power Loss Configuration for SSTL-2

If power loss is a major concern, separated the PV_{CC} from the AV_{CC} and the V_{DDQ} will be a good choice. The PV_{CC} can operate at lower voltage (1.8V to 2.5V). If 2.5V voltage is applied on AV_{CC} and the V_{DDQ}, but the source current is lower due to the lower operating voltage applied on the PV_{CC}. Please find the relative test result in Figures 5, 11 and 12.

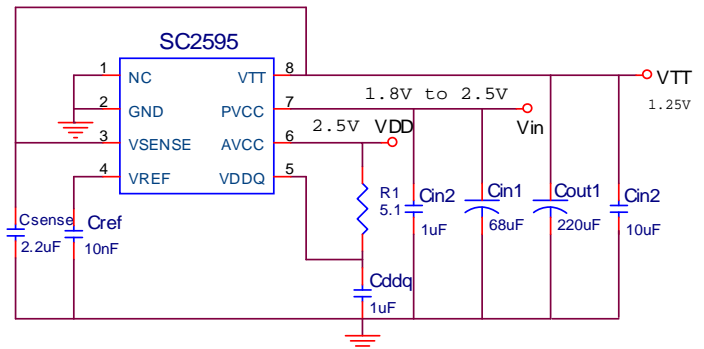

Figure 2: Lower power loss for SSTL-2 application

Notes:

- (1) Power up of AV_{CC}, PV_{CC} and V_{DDQ} supplies.
 - (a) The preferred mode of operation is when the AV_{CC}, PV_{CC} and V_{DDQ} pins are tied together to a single supply.
 - (b) If and when AV_{CC}, PV_{CC} pins are tied to a supply separate to that of the V_{DDQ} supply pin; then the V_{DDQ} supply should lead AV_{CC}, PV_{CC} supply or the V_{DDQ} supply and the AV_{CC}, PV_{CC} supply should rise simultaneously.
 - (c) If the AV_{CC}, PV_{CC} and V_{DDQ} supply pins are connected in a way such that, AV_{CC}, PV_{CC} supplies precedes V_{DDQ} supply; then V_{TT} output precedes V_{DDQ}. This can cause the SDRAM device to latch-up, which may cause permanent damage to the SDRAM.

POWER MANAGEMENT**Application Information (Cont.)****Layout guidelines**

1)The SC2595 has a SOIC8-EDP package. It can improve the thermal impedance (θ_{JC}) significantly. A suitable thermal pad should be added when PCB layout. Some thermal vias are required to connect the thermal pad to the PCB ground layer. This will improve the thermal performance .

2)To increase the noise immunity, a ceramic capacitor of 10nf to 100nf is required to decouple the V_{REF} pin with the shortest connection trace, also A 10nF to 100nF ceramic capacitor close to the V_{SENSE} pin is required to avoid oscillation during transient condition.

3)To reduce the noise on the input power rail for standard SSTL-2 application, a 68 μ F low ESR capacitor and a 1 μ F ceramic capacitor have to be used on the input power rail with shortest possible connection.

4)For lower power loss SSTL-2 application, a 220 μ F AL capacitor (ESR should be lower than 250m ohm) and a 10 μ F ceramic has to be added on the PV_{CC} pin and a 1 μ F ceramic capacitor +5.1 ohm filter has to be added on the V_{DDQ} pin with shortest possible connection.

5) V_{TT} output copper plane should be as large as possible.

6) V_{SENSE} trace should be as short as possible.

POWER MANAGEMENT

Test Waveforms

Test condition: Avcc=PVcc=VDDQ=2.5V, VTT=1.25V
Cout1=220uF, Cout2=10uF, Source 2A.

30-Apr-04
11:56:22

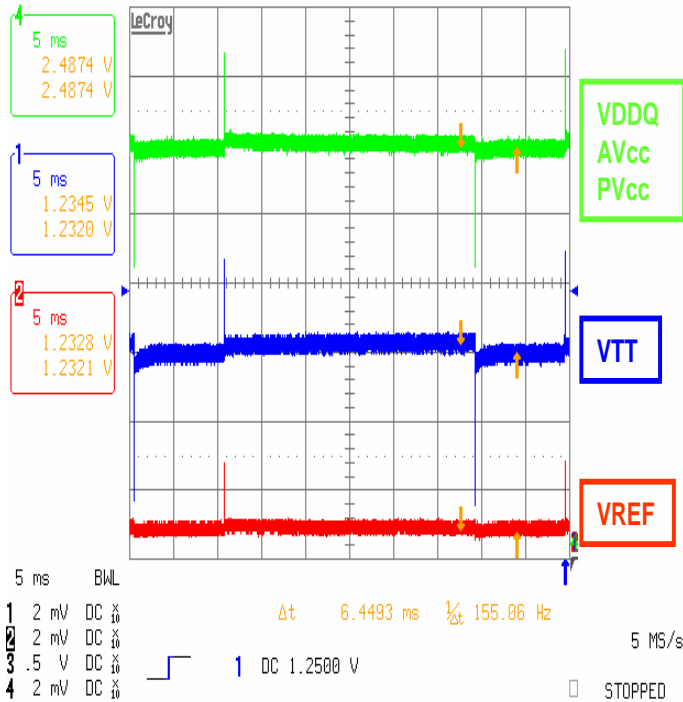

Figure 3

Test condition: Avcc=PVcc=VDDQ=2.5V, VTT=1.25V
Cout1=220uF, Cout2=10uF, Sink 2A.

30-Apr-04
11:55:23

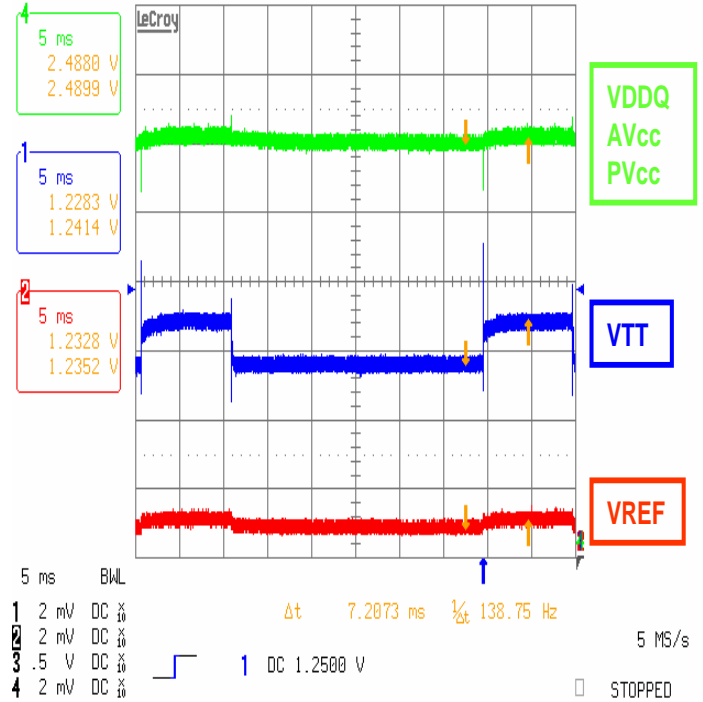

Figure 4

Typical Characteristics

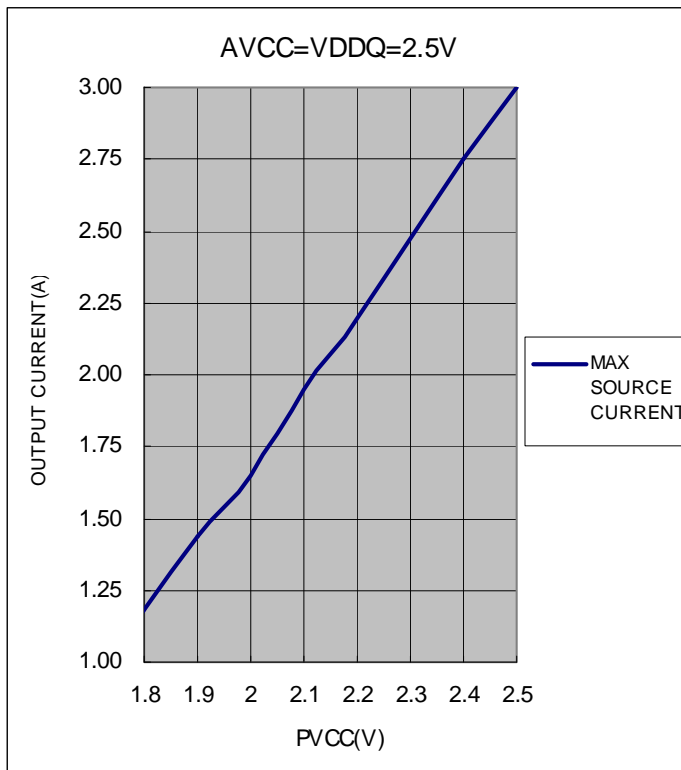

Figure 5

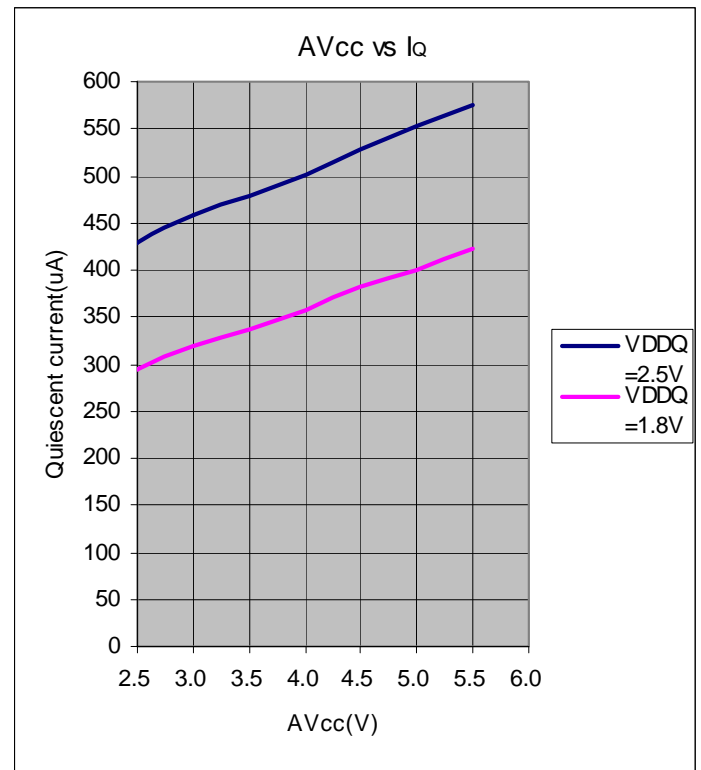

Figure 6

POWER MANAGEMENT

Typical Characteristics (Cont.)

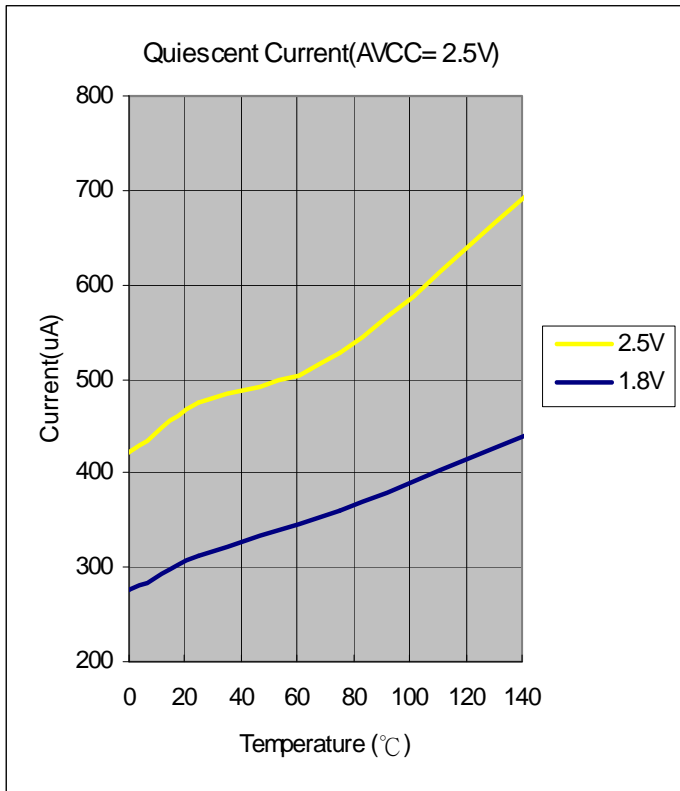

Figure 7

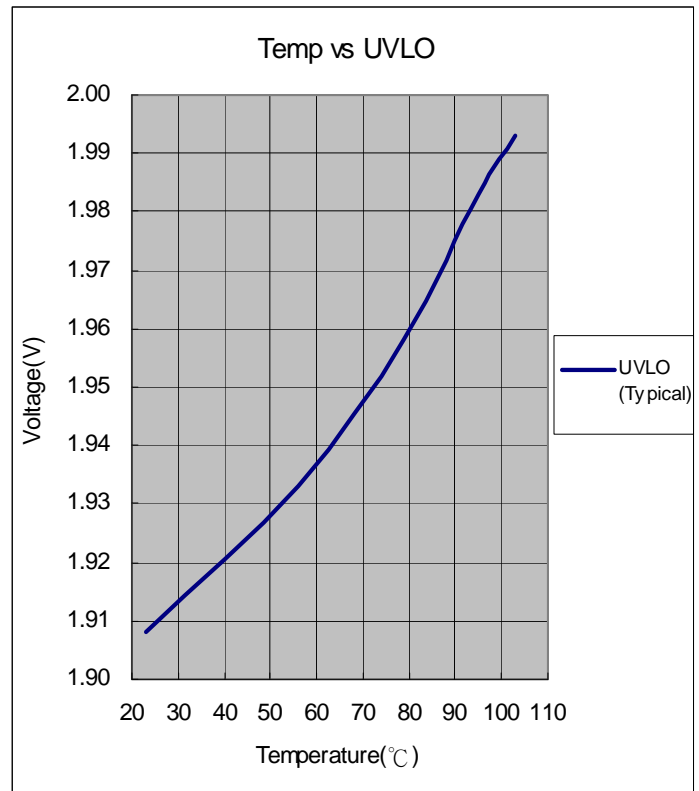

Figure 8

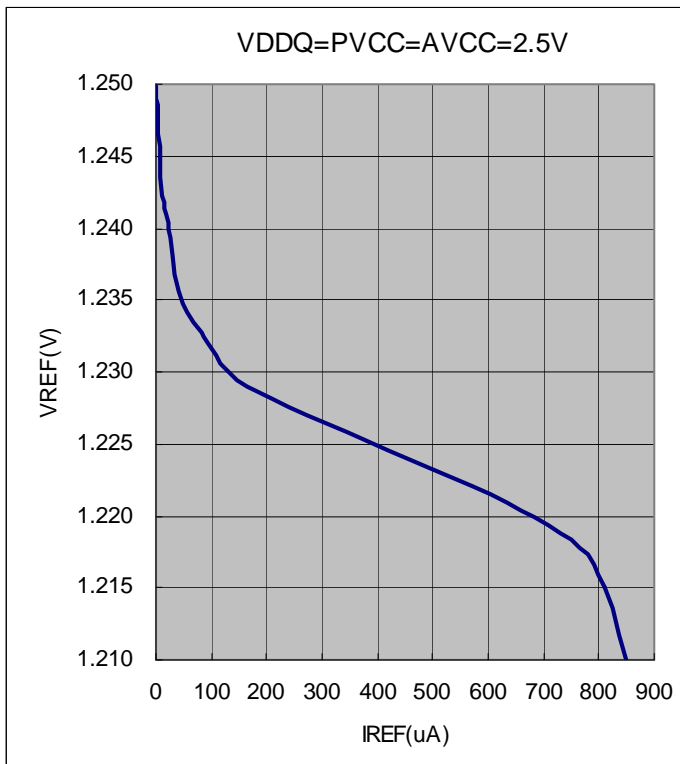

Figure 9

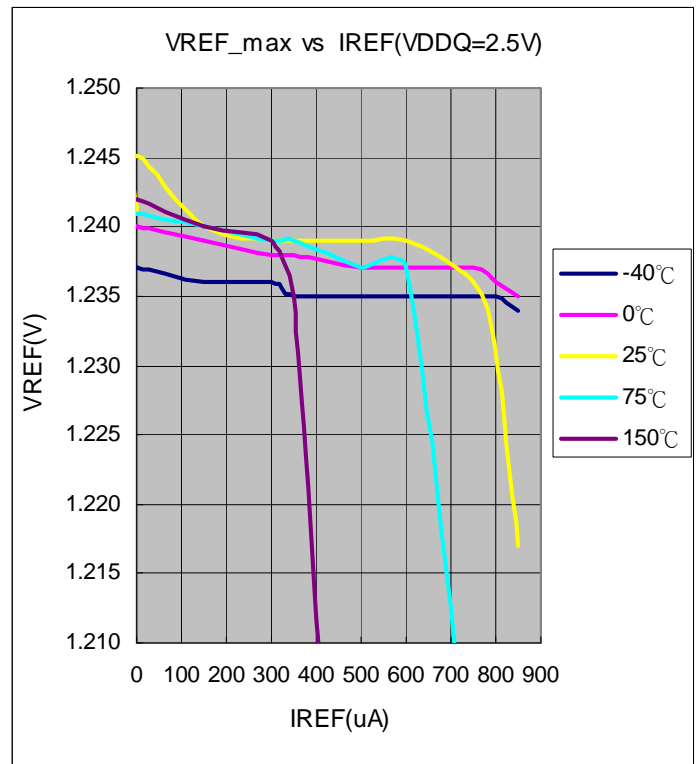

Figure 10

POWER MANAGEMENT

Typical Characteristics (Cont.)

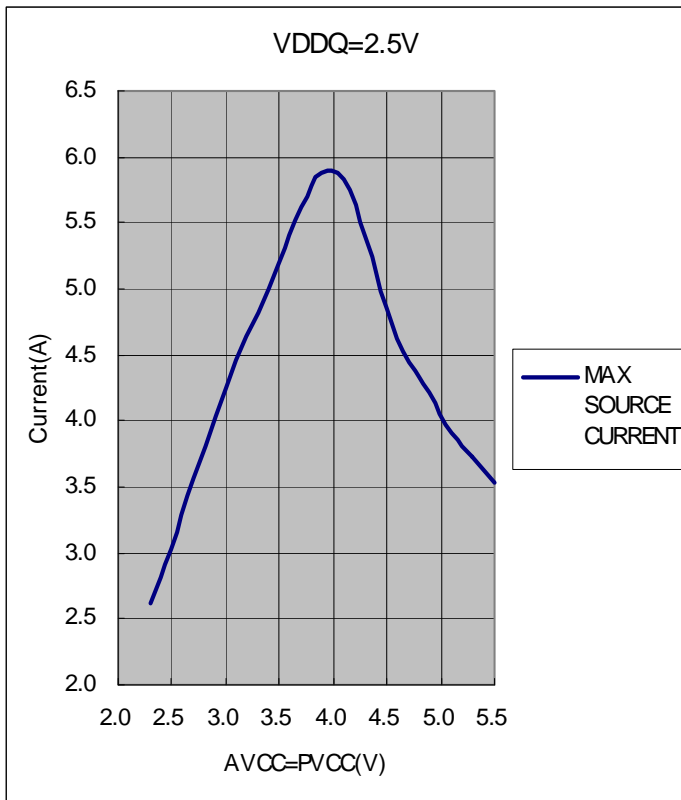

Figure 11

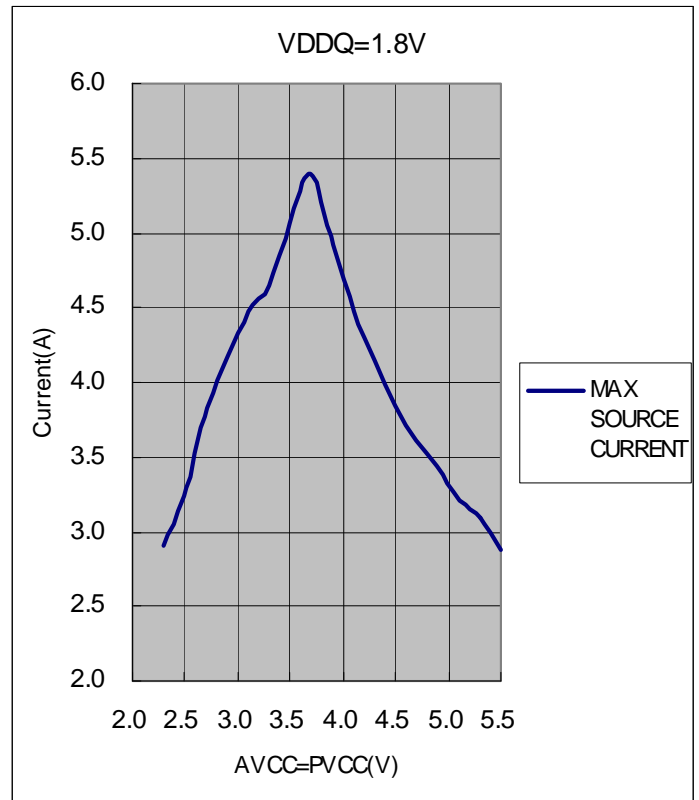

Figure 12

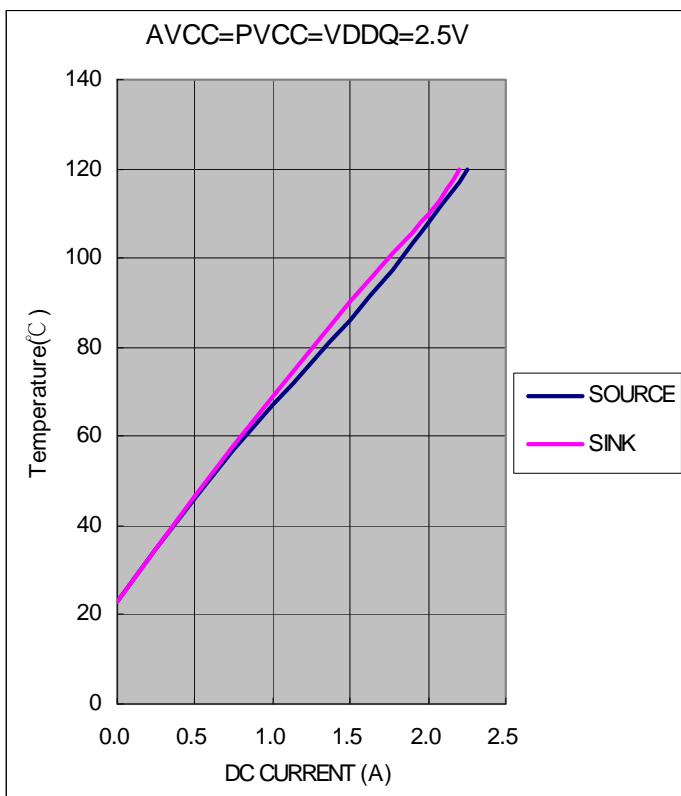
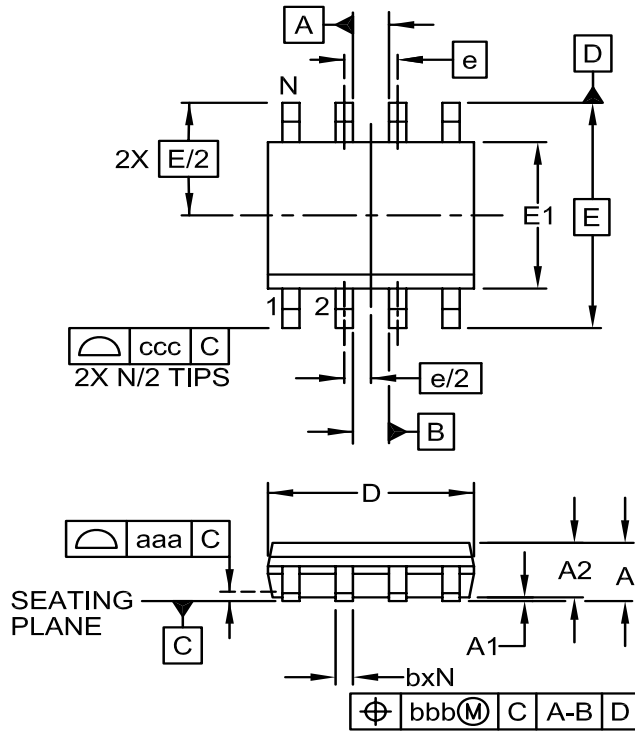

Figure 13

POWER MANAGEMENT

Outline Drawing - SOIC8-EDP



DIM	INCHES			MILLIMETERS		
	MIN	NOM	MAX	MIN	NOM	MAX
A	.053	-	.069	1.35	-	1.75
A1	.000	-	.005	0.00	-	0.13
A2	.049	-	.065	1.25	-	1.65
b	.012	-	.020	0.31	-	0.51
c	.007	-	.010	0.17	-	0.25
D	.189	.193	.197	4.80	4.90	5.00
E1	.150	.154	.157	3.80	3.90	4.00
E	.236 BSC			6.00 BSC		
e	.050 BSC			1.27 BSC		
F	.086	-	.130	2.19	-	3.30
H	.085	-	.099	2.15	-	2.51
h	.010	-	.020	0.25	-	0.50
L	.016	.028	.041	0.40	0.72	1.04
L1	(.041)			(1.05)		
N	8			8		
θ_1	0°	-	8°	0°	-	8°
aaa	.004			0.10		
bbb	.010			0.25		
ccc	.008			0.20		

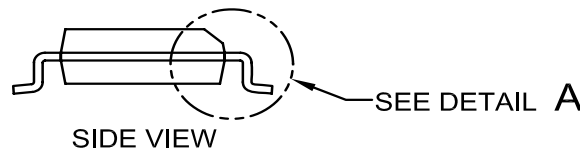
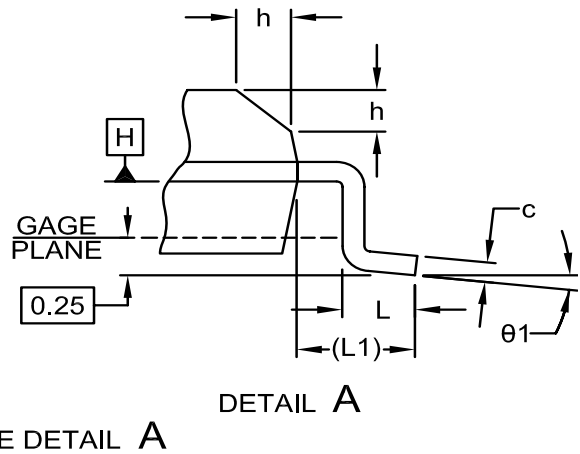

NOTES:

1. CONTROLLING DIMENSIONS ARE IN MILLIMETERS (ANGLES IN DEGREES).
2. DATUMS **-A-** AND **-B-** TO BE DETERMINED AT DATUM PLANE **-H-**
3. DIMENSIONS "E1" AND "D" DO NOT INCLUDE MOLD FLASH, PROTRUSIONS OR GATE BURRS.

POWER MANAGEMENT

Land Pattern - SOIC8-EDP

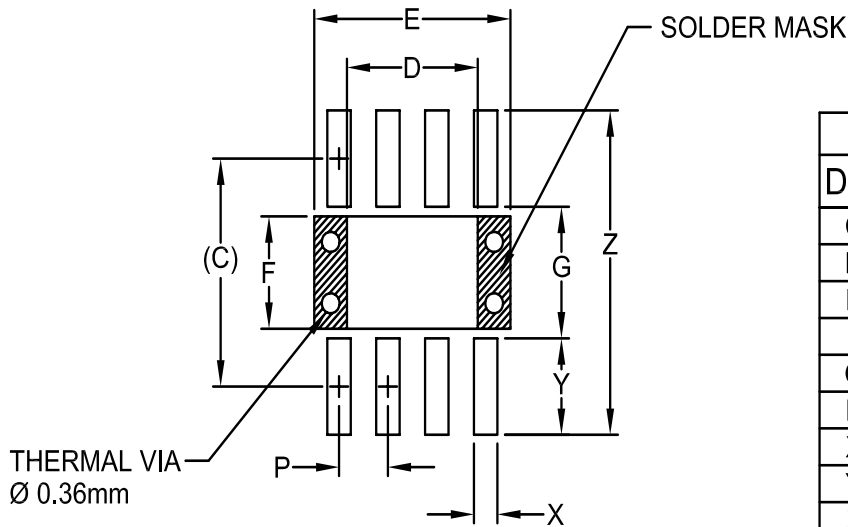

DIMENSIONS		
DIM	INCHES	MILLIMETERS
C	(.205)	(5.20)
D	.134	3.40
E	.201	5.10
F	.101	2.56
G	.118	3.00
P	.050	1.27
X	.024	0.60
Y	.087	2.20
Z	.291	7.40

NOTES:

1. CONTROLLING DIMENSIONS ARE IN MILLIMETERS (ANGLES IN DEGREES).
2. THIS LAND PATTERN IS FOR REFERENCE PURPOSES ONLY. CONSULT YOUR MANUFACTURING GROUP TO ENSURE YOUR COMPANY'S MANUFACTURING GUIDELINES ARE MET.
3. REFERENCE IPC-SM-782A, RLP NO. 300A.
4. THERMAL VIAS IN THE LAND PATTERN OF THE EXPOSED PAD SHALL BE CONNECTED TO A SYSTEM GROUND PLANE. FAILURE TO DO SO MAY COMPROMISE THE THERMAL AND/OR FUNCTIONAL PERFORMANCE OF THE DEVICE.

Contact Information

Taiwan Branch Tel: 886-2-2748-3380
Fax: 886-2-2748-3390

Korea Branch Tel: 82-2-527-4377
Fax: 82-2-527-4376

Shanghai Office Tel: 86-21-6391-0830
Fax: 86-21-6391-0831

Semtech Switzerland GmbH Tel: 81-3-6408-0950
Japan Branch Fax: 81-3-6408-0951

Semtech Limited (U.K.) Tel: 44-1794-527-600
Fax: 44-1794-527-601

Semtech France SARL Tel: 33-(0)169-28-22-00
Fax: 33-(0)169-28-12-98

Semtech Germany GmbH Tel: 49-(0)8161-140-123
Fax: 49-(0)8161-140-124

Semtech International AG is a wholly-owned subsidiary of Semtech Corporation, which has its headquarters in the U.S.A.