

Data sheet

OpDAT 24 PF 1RU patch panel fixed installation 6xSC-D MM (ceramic, heather violet) pigtails OM4 placed and stripped

P/N
150207BB06-E
EAN 4250184168768

2015-22-06

Illustrations



Dimensional drawing

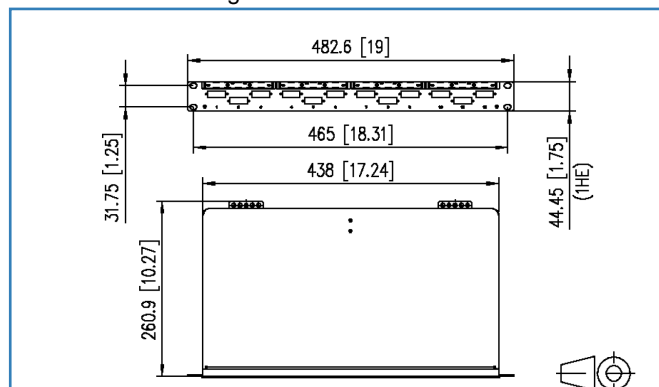

See enlarged drawings at the end of document

Product specification

- 19 inch 1RU fiber optic patch panel for fixed installation
 - light aluminum construction
 - equipped with SC-D couplers (metal)
 - unused cutouts are closed by blank plugs
 - removable front plate for easy adapter mounting
 - variable cable entry (straight / inclined) from both sides possible
 - cable relief with supplied cable tie or optional cable screw connection also possible
 - cable diameter from 3 to 20 mm
 - strain relief for central element / Kevlar
 - cable management by means of freely positionable guide elements
 - snap-on cover for easy access during service work
 - label window for enclosed identification labels
 - compact conductor pigtails with dia. 0.9 mm, length 2.0 m
 - pigtails inserted and stripped in standard splice trays with crimp splice holders
 - pigtails are cleaned and plugged in couplers
- variants: equipped with 6 or 12 SC-D couplers and pigtails each made of metal (OS2), heather violet (OM4), aqua (OM3) or metal (OM2)



**OpDAT 24 PF 1RU patch panel fixed installation
6xSC-D MM (ceramic, heather violet) pigtailed OM4 placed and
stripped**

P/N
150207BB06-E
EAN 4250184168768

2015-22-06

Technical Data

General Data

Fields of application	Structured building cabling, Data center
Design	patch panel
Mounting style	1RU
Transmission technology	Fiber optic
Port numbering	yes
Color	heather violet
Dimensions	
Dimension (L x W x H)	260.90 x 482.60 x 44.45 mm
Dimension (L x W x H)	10.27 x 19.00 x 1.75 in.
Inches	19 inches
Height unit	1RU
Number of cables/ cores	12
Cable Type	pigtail(s)
Fiber class	OM4 (ISO/IEC 11801/EN 50173 & IEC 60793-2-10/EN 60793-2-10 A1.a.1)
Mode type of the fiber	Multimode
Labeling option	label window with identification label + printed numbers

Connections/interfaces

Connector technology interface 1	SC-D Couplers
Connector technology interface 2	SC-D Couplers
Number of ports interface 1	12
Number of ports interface 2	12
Number of equipped ports interface 1	6
Number of ports interface 2 equipped	6
Number of ports with dust protection interface 2	6
Number of blind covers interface 2	6
Semi-tight buffered fiber pigtail length	2.00 m
Semi-tight buffered fiber pigtail length	6.56 ft
Semi-tight buffered fiber pigtail diameter	0.90 mm
Semi-tight buffered fiber pigtail diameter	0.04 in.
Cable access/outlet	variable, straight / inclined, from both sides possible



**OpDAT 24 PF 1RU patch panel fixed installation
6xSC-D MM (ceramic, heather violet) pigtailed OM4 placed and
stripped**

P/N
150207BB06-E
EAN 4250184168768

2015-22-06

Technical Data

Electrical characteristics

Insertion loss	max. 0.4 dB
Return loss	min. 20 dB

Mechanical characteristics

Cut-out	SC-D, LC-Q, ST-D
Connector type	Duplex
Life - Number of mating cycles	min. 1000
Strain relief	yes

Materials and material properties

Material - Coupler housing	Plastics
Material - Front cover	Al (Aluminium)
Material - Sleeve	ceramic, slotted

Approvals

RoHS	compliant
------	-----------

The product meets the following standards

Fibre optic connector interfaces	DIN EN 61754-4
----------------------------------	----------------

Classifications

ETIM 5.0	EC001130
----------	----------

Packing details

Type of packaging	1 pc(s) / box
Packaging unit - Weight (gram)	2085.00 g
Packaging unit - Weight (pound)	82.09 lb
Packaging dimension (W x H x D)	523.00 x 361.00 x 45.00 mm
Packaging dimension (W x H x D)	20.59 x 14.21 x 1.77 in.



Data sheet

Page 4/7

**OpDAT 24 PF 1RU patch panel fixed installation
6xSC-D MM (ceramic, heather violet) pigtails OM4 placed and
stripped**

P/N
150207BB06-E
EAN 4250184168768

2015-22-06

Accessories

P/N	Designation
899789-01	Label sheet for E-DAT C6 and E-DAT design patch panels



Data sheet

Page 5/7

**OpDAT 24 PF 1RU patch panel fixed installation
6xSC-D MM (ceramic, heather violet) pigtails OM4 placed and
stripped**

P/N
150207BB06-E
EAN 4250184168768

2015-22-06

Illustrations

Dimensional drawing

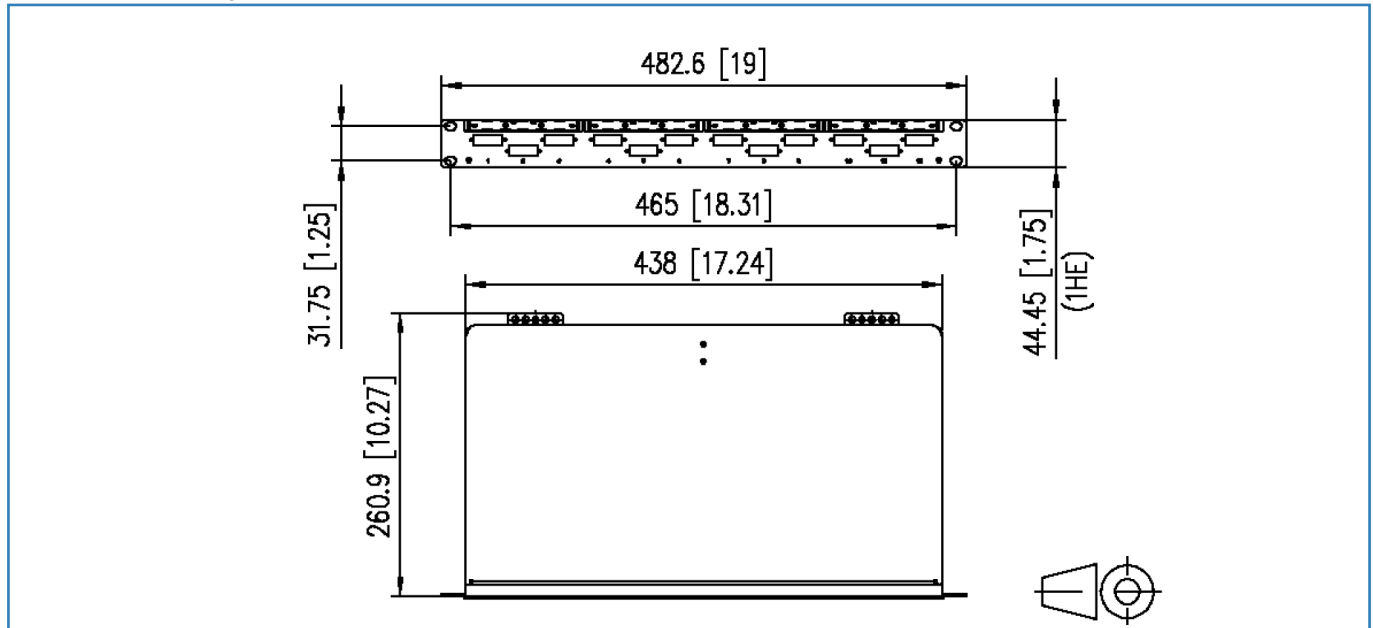

Technical Data

General Data

Transmission technology	Fiber optic
Mode type of the fiber	Multimode
Fiber class	OM4 (ISO/IEC 11801/EN 50173 & IEC 60793-2-10/EN 60793-2-10 A1.a.3)
Fiber construction	50/125 µm

Transmission characteristics

Transmission rate up to 100 GBit	IEEE 802.3ba
Reach	
Reach 100BASE	2000 m
Reach 1000BASE LX	550 m
Reach 1000BASE SX	1000 m
Reach 10GBASE LX4	300 m
Reach 10GBASE SW/SR	550 m
Reach 40GBASE SR4	150 m
Overfilled (OFL) modal bandwidth at 850 nm (min.)	3500 MHz * km
Overfilled (OFL) modal bandwidth at 1300 nm (min.)	500 MHz * km
Effective modal bandwidth (EMB) at 850 nm (min.)	4700 MHz * km

Connections/interfaces

Connector technology interface 1	Free line end
Connector technology interface 2	Free line end
Fiber core diameter	50 ± 2.0 µm
Fiber cladding diameter	125.0 ± 1.0 µm
Primary coating diameter - colored	242 ± 0.5 µm
Primary coating diameter - uncolored	250 ± 15 µm

Electrical characteristics

Maximum value of cable attenuation at 850 nm	3.0 dB/km
Maximum value of cable attenuation at 1300 nm	1.0 dB/km

Mechanical characteristics

Proof stress level	min. 0.7 (~ 1 %) GPa
Strip force (peak)	1.3 = F _{peak.strip} max. 8.9 N
Fiber bending loss R=7.5 mm 850/1300 nm	max. 0.2 / = 0.5 dB
Fiber bending loss R=15 mm 850/1300 nm	max. 0.1 / = 0.3 dB

Data sheet
OpDAT fiber OM4 BR

Page 7/7

P/N
150XXX7

2015-22-06

Technical Data

Mechanical characteristics

Fiber cladding non-circularity	max. 0.7 %
Core non-circularity	max. 5 %
Core (MDF)-cladding concentricity error	max. 1.5 µm
Primary coating concentricity error	max. 5 %
Primary coating-cladding concentricity error	max. 6
Inhomogeneity of OTDR trace for any two 1000 metre fiber length	max. 0.1 dB/km
Group refractive index at 1310 and 1550 nm	1.482
Group refractive index at 1625 nm	1.477
Numerical aperture	0.200 ± 0.015

Materials and material properties

Bend insensitivity	Ja
--------------------	----

The product meets the following standards

Generic cabling systems	
General requirements	ISO/IEC 11801 DIN EN 50173-1
Optical fibers: Generic specification - basic test procedures for optical cables	
General and definitions	ISO/IEC 60794-1-20
Mechanical Tests Methods	ISO/IEC 60794-1-21
Optical fibers: Measuring methods and test procedures	
Fibre proof test	ISO/IEC 60793-1-30
Coating strippability	ISO/IEC 60793-1-32
Numerical aperture	ISO/IEC 60793-1-43
Optical fibers: Indoor optical cables	
Family specification for simplex and duplex cables	ISO/IEC 60793-2-10 (A1a.3)
TIA/ANSI-492	AAAD

Packing details

Primary coating diameter - colored	242 ± 0.5 µm
------------------------------------	--------------

