

Data sheet

OpDAT Industry IP67 2SC SM mounting flange

Page 1/4

P/N

1501706303-E

EAN 4250184108108

2015-19-06

Illustrations



Dimensional drawing

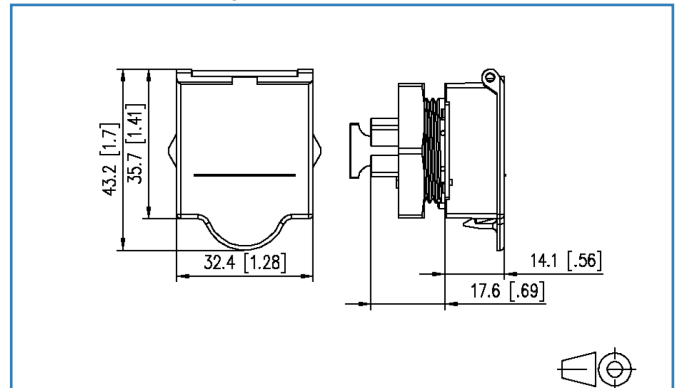

See enlarged drawings at the end of document

Product specification

- flange with fine thread with two optical SC jacks and two retrofittable electrical socket contacts for AWG 22-24
- IP67 fiber optic plug system for rough environments
- alternatively with M25x1.5 screw fastening (nut) or with four M3 screws
- easy-to-mount round installation cutout (diameter: 25 mm) with notch to prevent twisting
- SC and 2SC compatibility on IP20 end of the mounting flange
- labeling area on edge of mounting flange
- solid screw connection
- variants: 2SC SM and 2SC MM (also for POF)

Data sheet
OpDAT Industry IP67 2SC SM mounting flange

Page 2/4

P/N
1501706303-E
EAN 4250184108108

2015-19-06

Technical Data

General Data

Fields of application	Harsh environment
Design	Jack
Transmission technology	Fiber optic
Color	light gray
Dimensions	
Dimension (L x W x H)	35.80 x 32.40 x 42.80 mm
Dimension (L x W x H)	1.41 x 1.28 x 1.69 in.
Mode type of the fiber	Single mode
Labeling option	on housing

Connections/interfaces

Connector technology interface 2	SC
Number of ports interface 2	1
Number of ports interface 2 equipped	1
Protective housing interface 1	yes
Protective housing interface 2	yes

Mechanical characteristics

Cut-out	SC, LC-D, E2000
Life - Number of mating cycles	min. 1000

Materials and material properties

Material - Housing	Plastics
--------------------	----------

Environmental conditions

Particulate ingress	IP6X with protective housing
Liquid ingress/immersion	IPX7 with protective housing

Certifications

Gost Certification	yes
--------------------	-----

Data sheet
OpDAT Industry IP67 2SC SM mounting flange

Page 3/4

P/N
1501706303-E
EAN 4250184108108

2015-19-06

Technical Data

Approvals

RoHS compliant

The product meets the following standards

Generic cabling systems	
Industrial area	ISO/IEC 24702 AMD 1
Degrees of Protection Provided by Enclosures	IEC 60529:2014-09

Classifications

ETIM 5.0 EC001122

Packing details

Type of packaging	10 pc(s) / box
Packaging unit - Weight (gram)	257.00 g
Packaging unit - Weight (pound)	0.57 lb
Packaging dimension (D x W x H)	135.00 x 235.00 x 165.00 mm
Packaging dimension (D x W x H)	5.31 x 9.25 x 6.50 in.

© 2015 METZ CONNECT - Technische Änderungen vorbehalten! Subject to modifications! Sous réserve de modifications techniques!



Illustrations

Dimensional drawing

