

WITH ATTACHMENT

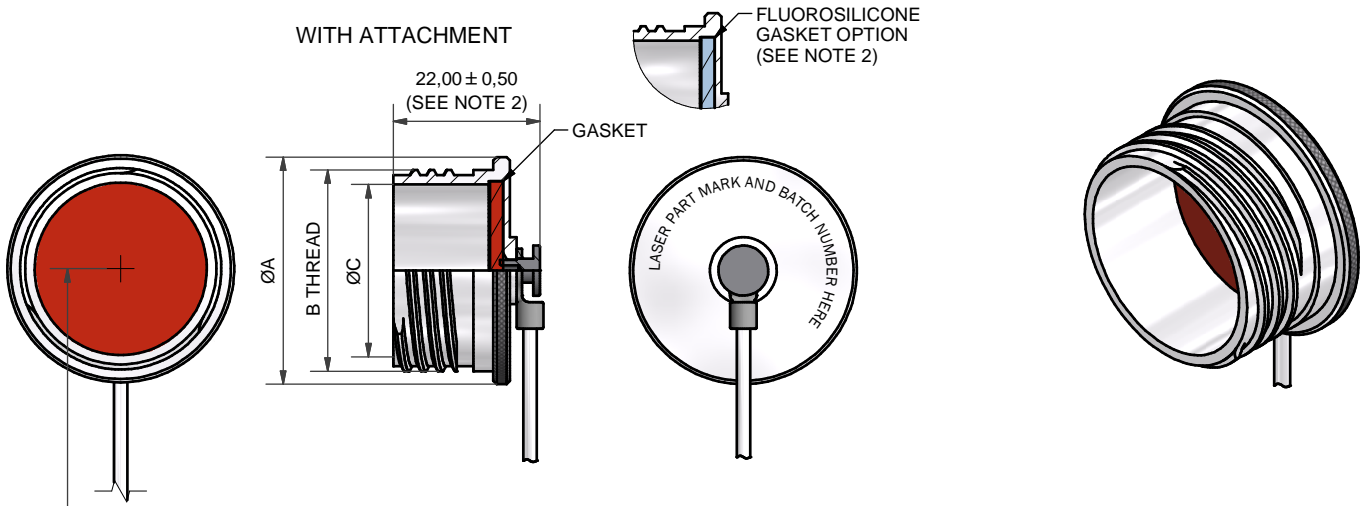

ATTACHMENT OPTIONS:

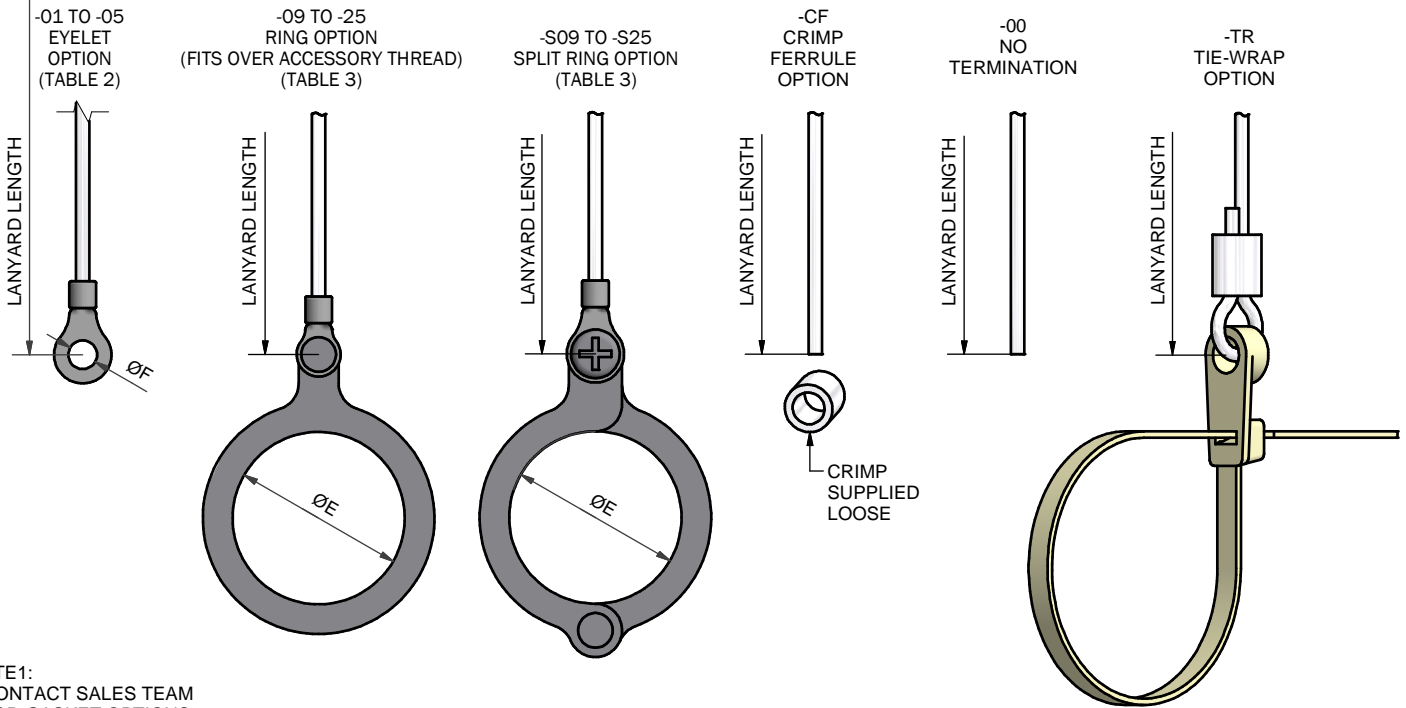

NOTE 1:  
CONTACT SALES TEAM  
FOR GASKET OPTIONS.

NOTE 2:  
DOES NOT APPLY FOR COMPOSITE  
(OPTION 74). ACTUAL VALUE FOR  
COMPOSITE IS 23,00 ± 0,50

OMIT FOR NO ATTACHMENT  
(SEE SHEET 2)

100P237-17-1-C-WR4-17

SERIES \_\_\_\_\_  
 INSERT 'F' FOR FLUOROSILICONE GASKET  
 OMIT FOR STANDARD SILICONE GASKET  
 SHELL SIZE (TABLE 1) \_\_\_\_\_  
 MATERIAL (TABLE 5) \_\_\_\_\_  
 FINISH (TABLE 6) \_\_\_\_\_  
 LANYARD TYPE (TABLE 4) \_\_\_\_\_  
 LANYARD LENGTH (IN INCHES) \_\_\_\_\_  
 +1,0"/-0" TOLERANCE  
 ATTACHMENT (SEE ABOVE) \_\_\_\_\_

DRAWN	K.SHEPPARD		DATE	10/02/2014	3RD ANGLE PROJECTION NOT TO SCALE
SALES APPR	A.POLSON		DATE	10/02/2014	
DESIGN APPR			UNLESS OTHERWISE SPECIFIED ALL DIMENSIONS IN MILLIMETRES GENERAL TOL LINEAR +/-0,25MM ANGULAR +/- 1°		
PROD APPR					
QUAL APPR					
ISSUE	REV.	DCR	MATERIAL SEE PART NUMBER BREAKDOWN		
11	2	3969			
NCAGE CODE U5792		WEIGHT	FINISH SEE PART NUMBER BREAKDOWN		

PART NUMBER:		100P237 SERIES	
TITLE:		PLUG PROTECTION CAP	
ASSY USED ON:		MIL-DTL-38999 SERIES III PLUG	
THIS DRAWING IS COPYRIGHT AND THE PROPERTY OF POLAMCO LTD IT MUST NOT BE COPIED, USED FOR MANUFACTURE OR OTHERWISE DISCLOSED WITHOUT PRIOR WRITTEN CONSENT OF THE COMPANY.		POLAMCO LTD, WESTON LOCK, LOWER BRISTOL ROAD BATH BA2 1EP	SHT 1

Polamco  
TE  
connectivity

DRAWING NO:  
P10270

TABLE 1

SHELL SIZE	ØA MAX	B THREAD	ØC MIN
09	21,0	0.625-0.1P-0.3L-TS	12,6
11	24,5	0.750-0.1P-0.3L-TS	15,8
13	28,0	0.875-0.1P-0.3L-TS	19,4
15	30,0	1.000-0.1P-0.3L-TS	22,6
17	34,0	1.1875-0.1P-0.3L-TS	25,8
19	37,0	1.250-0.1P-0.3L-TS	28,6
21	40,0	1.375-0.1P-0.3L-TS	31,8
23	43,0	1.500-0.1P-0.3L-TS	34,8
25	47,0	1.625-0.1P-0.3L-TS	38,1

TABLE 2

EYELET REF.	ØF
01	3,2
02	3,7
03	4,3
04	5,3
05	6,4

TABLE 3

RING REF.	SPLIT RING.REF	ØE
09	S09	15,1
11	S11	18,0
13	S13	19,4
15	S15	22,6
17	S17	25,8
19	S19	28,8
21	S21	32,0
23	S23	34,1
25	S25	40,1

TABLE 4

CODE	LANYARD TYPE
WR	NYLON COVERED (CLEAR) STAINLESS STEEL WIRE ROPE
TC	TEFLON COVERED (CLEAR) STAINLESS STEEL WIRE ROPE
WG	TEFLON COVERED (OLIVE DRAB) STAINLESS STEEL WIRE ROPE
WB	TEFLON COVERED (BLACK) STAINLESS STEEL WIRE ROPE
WRB	PVC COVERED (BLACK) STAINLESS STEEL WIRE ROPE
LC	LINK CHAIN
BK	BLACK CORD
VGB	1,5mm BLACK POLYESTER CORD EQV. TO DIN83330-E1,5
B	BEAD CHAIN
R	OLIVE DRAB POLYESTER CORD
NB	OLIVE DRAB NYLON CORD
NK	BLACK NYLON CORD

TABLE 5

CODE	MATERIAL
1	ALUMINIUM
2	NICKEL ALUMINIUM BRONZE
4	STAINLESS STEEL
7	BLACK ACETAL
74	COMPOSITE

LIST NOT EXHAUSTIVE, SEE MATERIAL TABLE FOR OTHER OPTIONS

TABLE 6

CODE	DESCRIPTION
B	CADMIUM, OLIVE DRAB OVER ELECTROLESS NICKEL
C	ELECTROLESS NICKEL
G	BLACK ANODISE, SULPHURIC
J	PASSIVATE
U	UNPLATED CLEAN FINISH NOT SHOT BLASTED
Z	SHOT BLAST FOR NON-REFLECTIVE FINISH
ZB	ZINC COBALT OLIVE DRAB OVER ELECTROLESS NICKEL
ZN	ZINC NICKEL BLACK PASSIVATE OVER ELECTROLESS NICKEL

LIST NOT EXHAUSTIVE, SEE PLATING TABLE FOR OTHER OPTIONS

WITHOUT ATTACHMENT

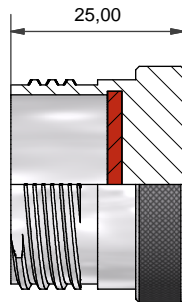

100P237-17-1-C  
NO ATTACHMENT VERSION

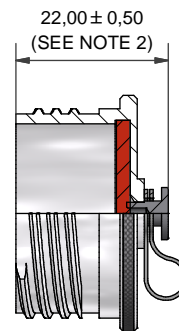

100P237-17-1-C-EO  
EYELET ONLY VERSION  
(NO LANYARD)

<b>DRAWN</b> K.SHEPPARD	<b>DATE</b> 10/02/2014		<b>PART NUMBER:</b>  100P237 SERIES	
<b>SALES APPR</b> A.POLSON	<b>DATE</b> 10/02/2014			
<b>DESIGN APPR</b>		UNLESS OTHERWISE SPECIFIED ALL DIMENSIONS IN MILLIMETRES <b>GENERAL TOL</b> LINEAR +/-0.25MM ANGULAR +/- 1°	<b>ASSY USED ON:</b> MIL-DTL-38999 SERIES III PLUG	POLAMCO LTD, WESTON LOCK, LOWER BRISTOL ROAD BATH BA2 1EP
<b>PROD APPR</b>				
<b>QUAL APPR</b>		NCAGE CODE U5792    WEIGHT	DRAWING NO: P10270	
<b>ISSUE</b> 11	<b>REV.</b> 2			<b>DCR</b> 3969