

a) Part as supplied.

TCFS-\*\*-\*\*\*-0\*\*-25BE

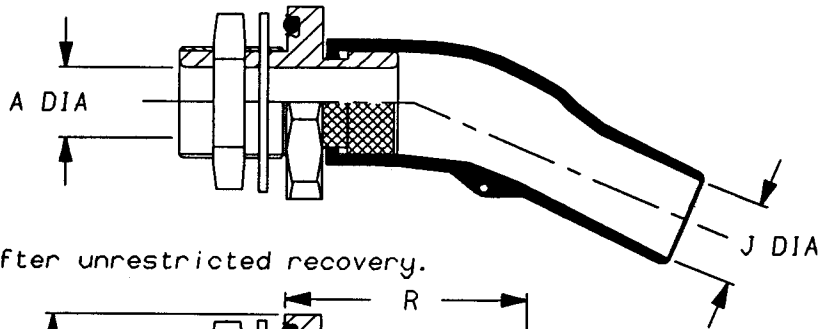

b) Part after unrestricted recovery.

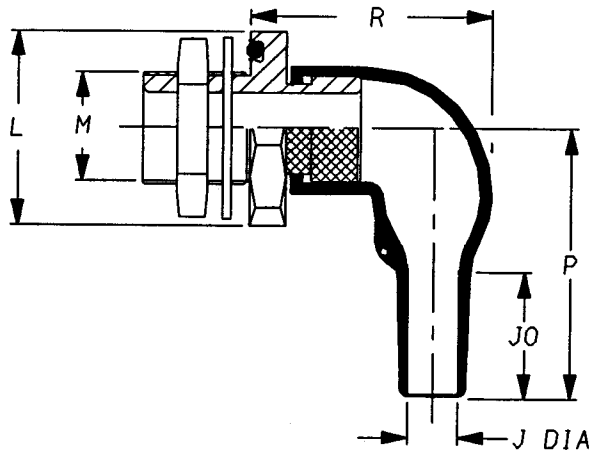

KITS TO INCLUDE CLEANING TISSUE, 1 PIECE 100 GRIT EMERY CLOTH.  
KIT TO BE USED IN CONJUNCTION WITH TCF5 INSTALLATION PROCEDURE.

Dimensions (in millimetres)

PART No.	A		J		M THREAD	A/F Nut	L NOM	P ±10% b	R ±10% b	J0 Ref b
	min	max	min a	max b						
TCFS-12	7.4	10	5.7	M12 x 1.5	17	24	25	30	9	
TCFS-16	10.1	13	6.0	M16 x 1.5	22	29	32	32	9	
TCFS-20	14.1	17	7.2	M20 x 1.5	27	34	39	36	15	
TCFS-24	19.1	23	8.5	M24 x 1.5	30	38	46	43	16	
TCFS-30	24.1	27	10.0	M30 x 1.5	36	47	55	50	17	
TCFS-36	30.1	33	15.8	M36 x 1.5	41	52	80	59	32	
TCFS-48	40.1	43	16.9	M48 x 1.5	55	67	108	73	48	

Copyright (!)

The copyright in this drawing is the property of Tyco Electronics UK Ltd. The drawing is issued on the condition that it is not copied, reproduced or disclosed to a third party, either in whole or in part without the prior written consent of Tyco Electronics UK Ltd.

Drawn A.LILLEY. Checked *[Signature]* Issue 1 Date May 2002

Conforms to ISO Recommendations  
3rd Angle Projection  
Not to Scale

Approval Design *[Signature]* MKTG. *[Signature]* G.A.

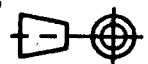

<b>Raychem</b>		<b>Specification Control Drawing</b>	Part Number TCFS-**-***-0**-25BE Issue 1
Details of Revisions			
Iss.	Date	E.C.R. No.	Details of Change

Materials		
Component	Description	Colour
Moulded part	(-25) Diesel Resistant Elastomer	Black

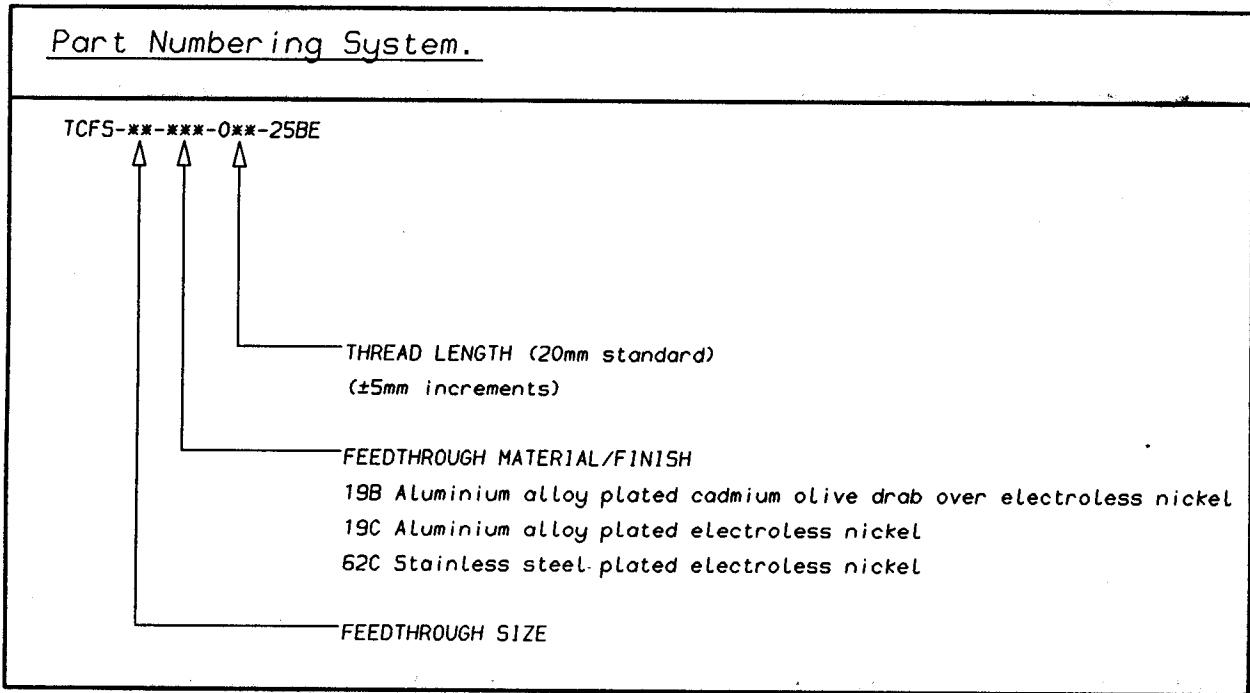

Tyco electronics UK Ltd. Faraday Road, Swindon, Wiltshire, SN3 5HH England Telephone: (01793) 528171 Fax: 572516	Tyco electronics Corporation 300, Constitution Drive, Menlo Park, CA 94025 USA Telephone (650) 361-3860 Fax: (650) 361-5579
Cage Code K1010	Cage Code 06090