

REVISIONS					
P	LTR	DESCRIPTION	DATE	DWN	APVD
	M1	REVISED PER ECN-25-308452	26FEB2025	MM	LR

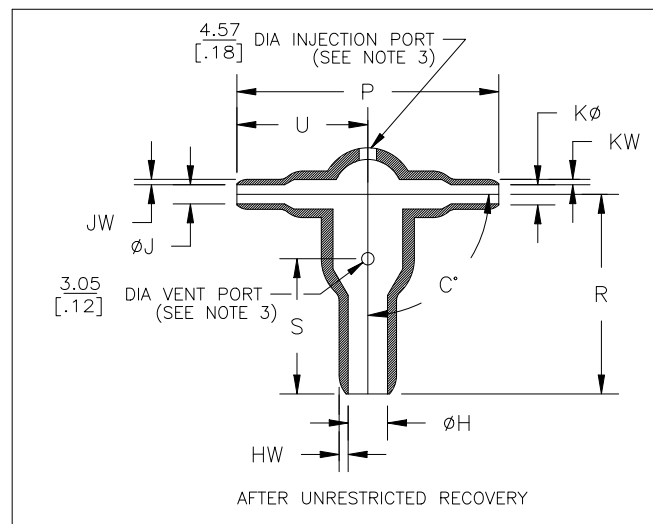

PART NUMBER	H		J & K		P	R	S	U	HW	JW & KW	C°
	Min a	Max b	Min a	Max b	±10% b	±10% b	±10% b	±10% b	±20% b	±20% b	±5° b
302A012	13.2 [.52]	6.1 [.24]	6.6 [.26]	3.0 [.12]	35.8 [1.41]	26.4 [1.04]	18.3 [.72]	17.8 [.70]	1.5 [.06]	1.0 [.04]	90°
302A024	26.9 [1.06]	12.4 [.49]	13.2 [.52]	6.1 [.24]	67.1 [2.64]	54.4 [2.14]	33.5 [1.32]	33.5 [1.32]	2.5 [.10]	1.5 [.06]	90°
302A037	55.6 [2.19]	25.4 [1.00]	26.9 [1.06]	12.4 [.49]	145.5 [5.73]	112.8 [4.44]	78.7 [3.10]	72.6 [2.86]	4.6 [.18]	2.5 [.10]	90°

TE Connectivity. All Rights Reserved.

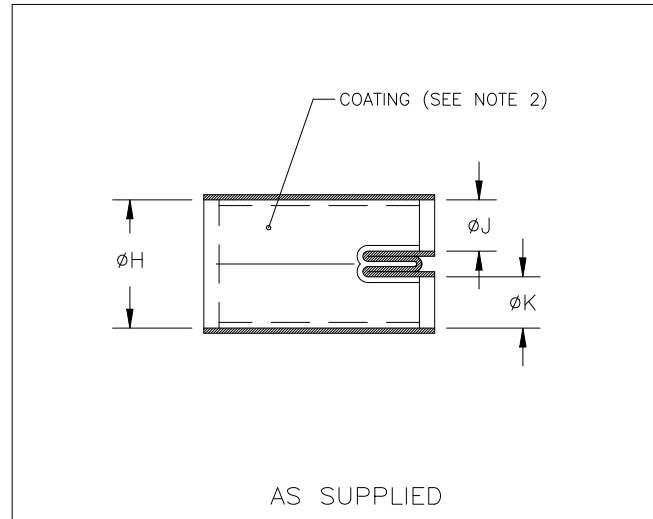

DIMENSIONS: mm [INCHES]	DWN PRAVEEN N T	29JAN2019	MATERIAL SEE SHEET 2	FINISH -
	CHK N NAGAR	29JAN2019	TE Connectivity Ltd.	
TOLERANCES UNLESS OTHERWISE SPECIFIED:	APVD M TAYLOR	29JAN2019		
0 PLC ± -	PRODUCT SPEC -		SIZE A4	CAGE CODE 00779
1 PLC ± -	APPLICATION SPEC -		DRAWING NO C-302A012-XX-0THRU037=XX-0	RESTRICTED TO
2 PLC ± -	WEIGHT -		SCALE DNS	SHEET 1 OF 2
3 PLC ± -				REV M1
4 PLC ± -				
ANGLES ± -				

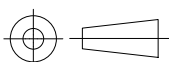

REVISIONS					
P	LTR	DESCRIPTION	DATE	DWN	APVD
	-	SEE SHEET 1	-	-	-

COMPATABILITY CHART				
MATERIAL DASH NO.	MATERIAL DESCRIPTION	RT SPEC	COATING SLASH NO.	COATING S NO.
-3	Polyolefin, Semi-rigid	RT-301	/42;/86;/180	S1017;S1048;S1030
-4	Polyolefin, Flexible	RT-1304	/42;/86;/180	S1017;S1048;S1030
-12	Fluoroelastomer, Flexible	RT-1312	N/A	N/A
-25	Elastomer, Fluid Resistant	RW-2070	/42;/86;/225	S1017;S1048;S1206
-100	Polyolefin, Simi-Flexible ZEROHAL	RW-2082	/86;/180	S1048;S1030

ORDERING INFORMATION

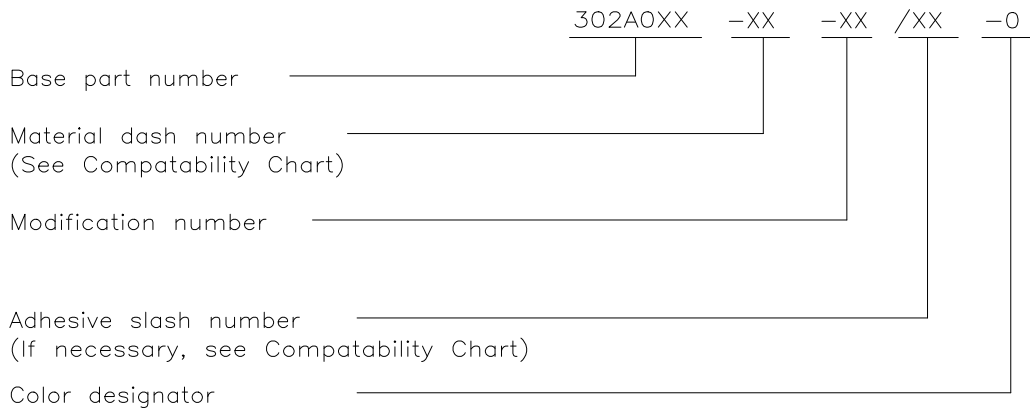

NOTES

- Dimensions appearing in table are as follows:
 - a - As Supplied
 - b - After Unrestricted Recovery
- Coating is optional. As supplied dimensions appearing in table are for uncoated parts. When coating is added, entry diameters will be reduced by 1.5mm[.06] max.
- Molding ports are optional. When -00 modification number is specified molding ports will be located as shown.

TE Connectivity. All Rights Reserved.

-



DIMENSIONS: mm [INCHES]	DWN PRAVEEN N T 29JAN2019	MATERIAL -	FINISH -
	CHK N NAGAR 29JAN2019	TE Connectivity Ltd.	
TOLERANCES UNLESS OTHERWISE SPECIFIED:	APVD M TAYLOR 29JAN2019		
0 PLC ± -	PRODUCT SPEC -	SIZE A4	CAGE CODE 00779
1 PLC ± -	APPLICATION SPEC -	DRAWING NO C-302A012-XX-0THRU037=XX-0	RESTRICTED TO
2 PLC ± -	WEIGHT	CUSTOMER DRAWING	
3 PLC ± -		SCALE DNS	SHEET 2 OF 2
4 PLC ± -			REV M1
ANGLES ± -			

