



Data Sheet	DMM-4026-B-I2S-R
------------	------------------

Specifications

Parameters	Condition	Values	Units
Directivity	Omnidirectional		
Data Format	I ² S 24-bit		
Sensitivity	1 kHz @ 50cm with 94 dB source 0 dB=1V/Pa	-26±1	dB
Rated Voltage	-	1.8	VDC
Operating Voltage Range	-	1.5 to 3.6	VDC
Supply Current	Normal Mode	820 ~ 1000	µA
	Sleep Mode (clock off)	5	µA
Signal-to-Noise Ratio	1kHz, 94 dB input, A-weighted	64	dB
Frequency Range	20~20,000		Hz
Total Harmonic Distortion (typical)	110 dB @ 50cm, 1 kHz acoustic source	1%	-
Startup Time	Sensitivity reaching 90% of listed value from initial power-up	20	mS
	From Sleep Mode	20	mS
	From Normal Mode to Sleep Mode	20	mS
Input Clock Frequency	Normal Mode	2.048 ~ 4.096	MHz
	Sleep Mode	320	kHz
Clock Jitter	Long Term RMS	500	pS
Load Capacitance	-	140	pF
Pass Band	Fs=48 kHz	18	kHz
Pass Band Attenuation	-	0.5	dB
Acceptable Soldering Methods	Reflow Solder		See page 4 for soldering information
Environmental Compliances	RoHS/Halogen Free		
Power Supply Rejection	100 mVpp Square Wave @ 217 Hz, A-weighted	-86	dBFS
Weight	<0.3		Grams
Operating Temperature	-40 ~ +100		°C
Storage Temperature	-40 ~ +125		°C
MSL (Moisture Sensitivity Level)*	1		-

*MSL level dependent on product remaining in sealed packaging until use

Measurement Method

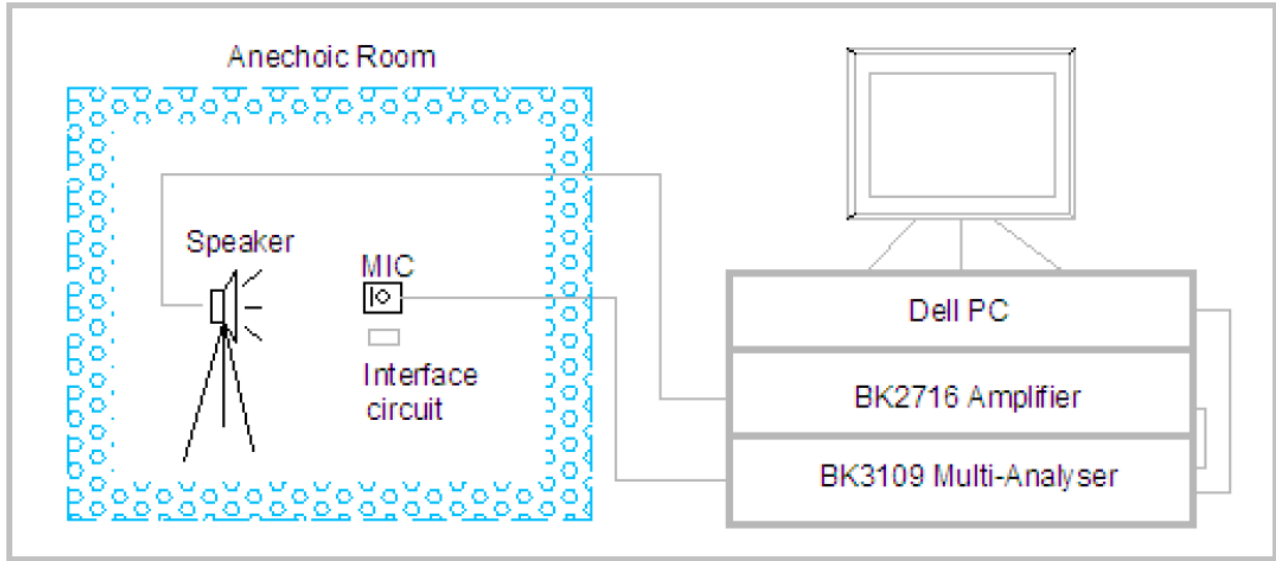

Measurement Interface Circuit

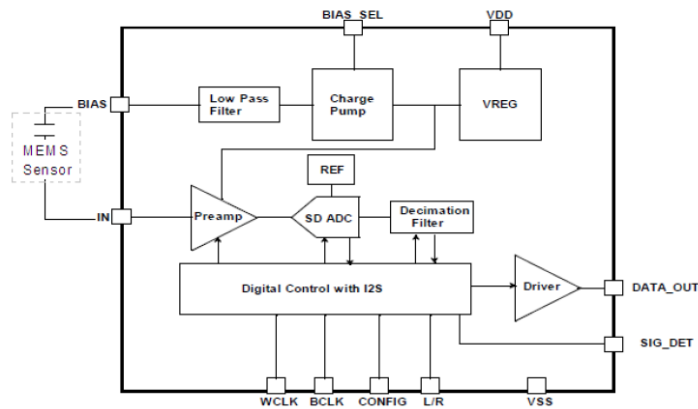

Functional Block Diagram

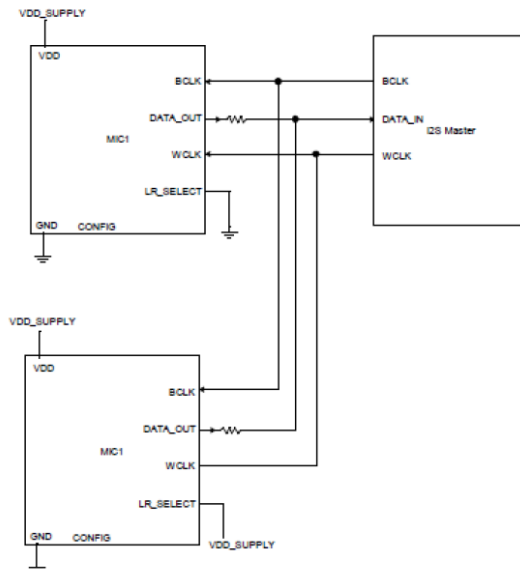

Interface diagram between I2S Master and 2 Microphones

Digital Interface Specifications

Parameters	Symbol	Condition	Value			Units
			MIN	Typical	MAX	
BCLK Frequency	BCLK	-	-	3.072	12.288	MHz
BCLK Duty Cycle	-	-	45	-	55	%
Data Valid	TDV	-	-	-	18	nS
WCLK Hold Time	THWCLK	Two mic mode	32 (1/BCLK)	-	-	nS
		Array mic mode	20	-	-	nS
WCLK Setup Time	TSWCLK	-	20	-	-	nS

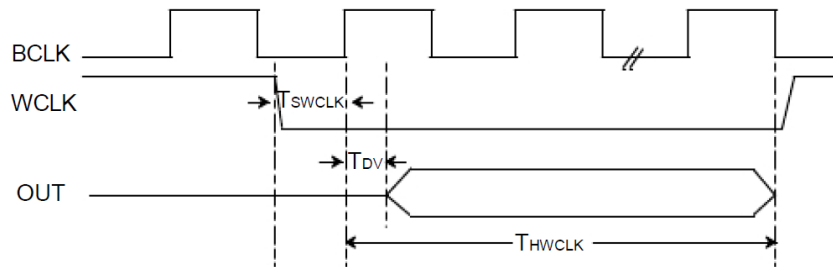

Interface timing diagram for two microphone Mode

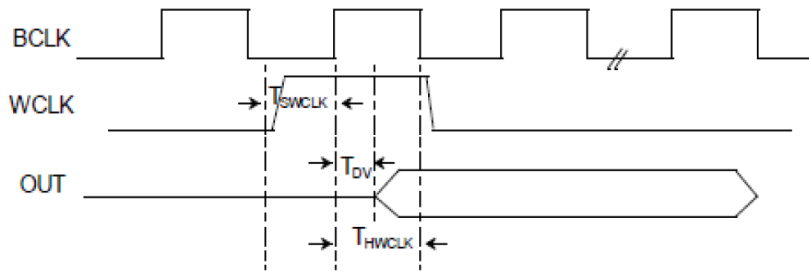

Interface timing diagram for Array microphone Mode

Typical Frequency Response (Microphone spaced 50cm from 94 dB acoustic source)

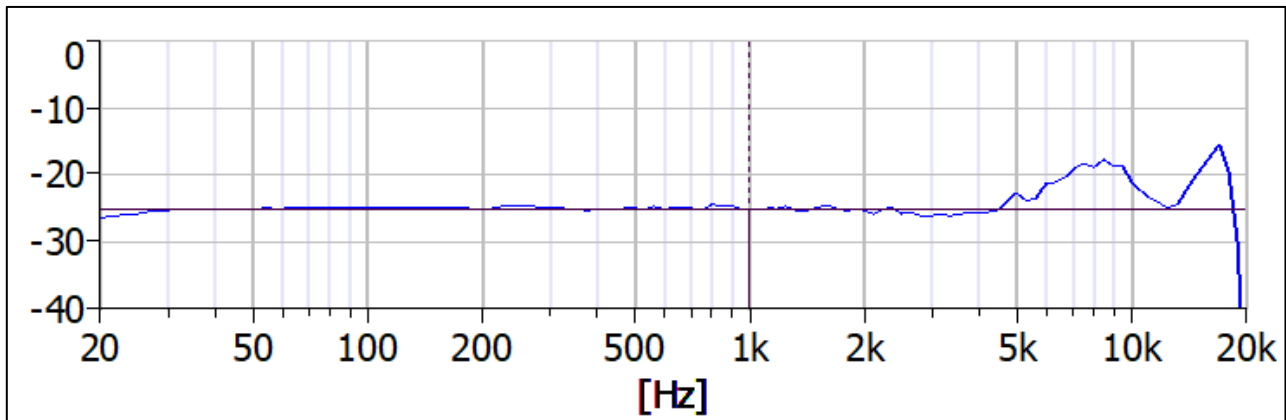

Recommended Soldering Procedure

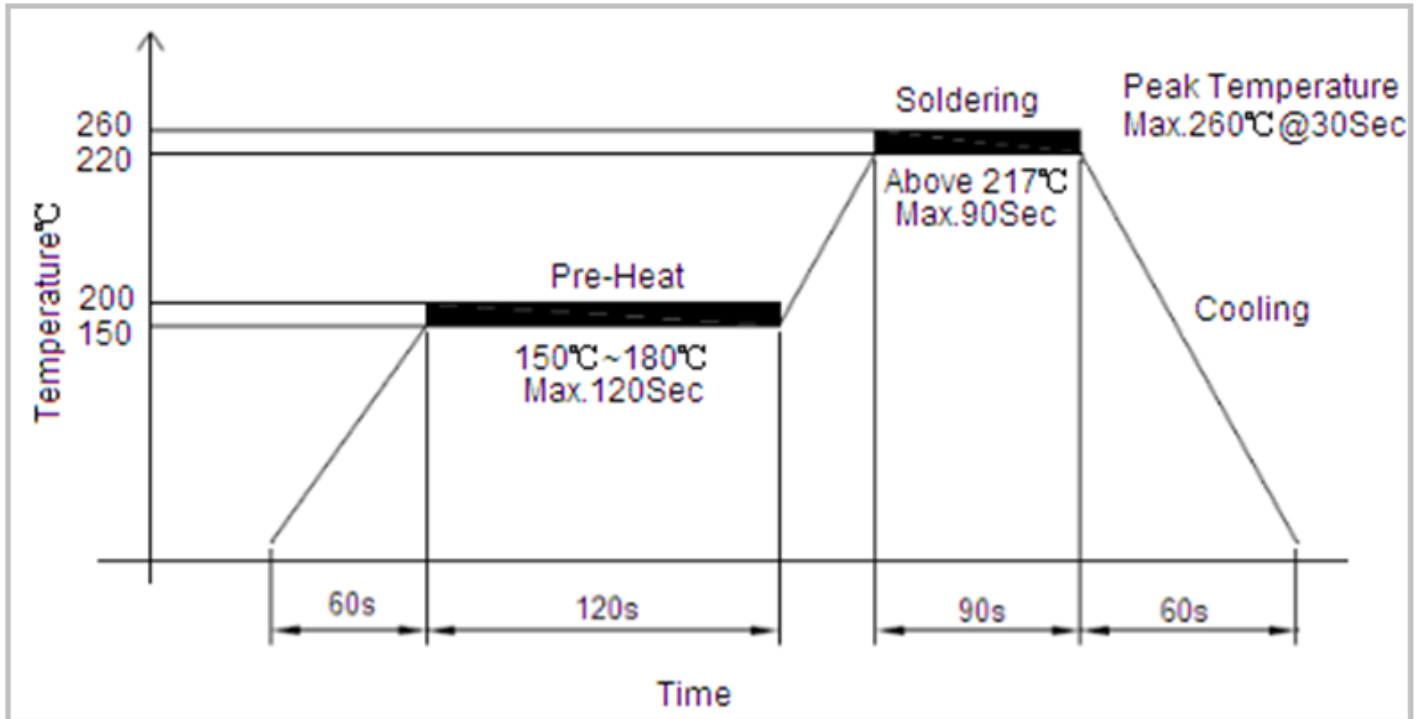

Important Notes to minimize device damage:

1. Do not boards wash or clean after the reflow process.
2. Do not apply over 0.3Mpa of air pressure into the port hole.
3. Do not expose to ultrasonic processing or cleaning.
4. Do not pull a vacuum over port hole of the microphone.

Reliability Testing

Type of Test	Test Specifications
Simulated Reflow (Without Solder)	Samples for qualification testing require 3 passes 260±5 °C reflow solder profiles. 2 hours of setting time is required between each reflow profile test.
Static Humidity	Precondition at +25°C for 1 hour. Expose to +85°C with 85% relative humidity for 1000 hours. Dry at room ambient for 3±1 hour before taking final measurement.
Temperature Shock	Each cycle shall consist of 30 minutes at -40°C, 30 minutes at +125°C with 5 minutes transition time. Test duration is for 30 cycles, starting from cold to hot temperature.
ESD Sensitivity	Perform ESD sensitivity threshold measurements for each contact according to MIL-STD-883G, Method 3015.7 for Human Body Model. Identify the ESD threshold levels indicating passage of 8000V Human Body Model.
Vibration Test	Vibrate randomly along three perpendicular directions for 30 minutes in each direction, 4 cycles from 20~2000 Hz with a peak acceleration of 20 Gs.
Shock Test	Subject samples to half-sine shock pulses (3000±15% Gs for 0.3ms) in each direction, for a total of 18 shocks.
Drop Test	Drop samples from 1.5m height onto a steel surface, total 18 times and inspected for mechanical damage.
Operation Life	Subject samples to +125°C for 168 hours under full maximum rated voltage.

Microphone frequency response and sensitivity shall not deviate more than ±3 dB.

Dimensions

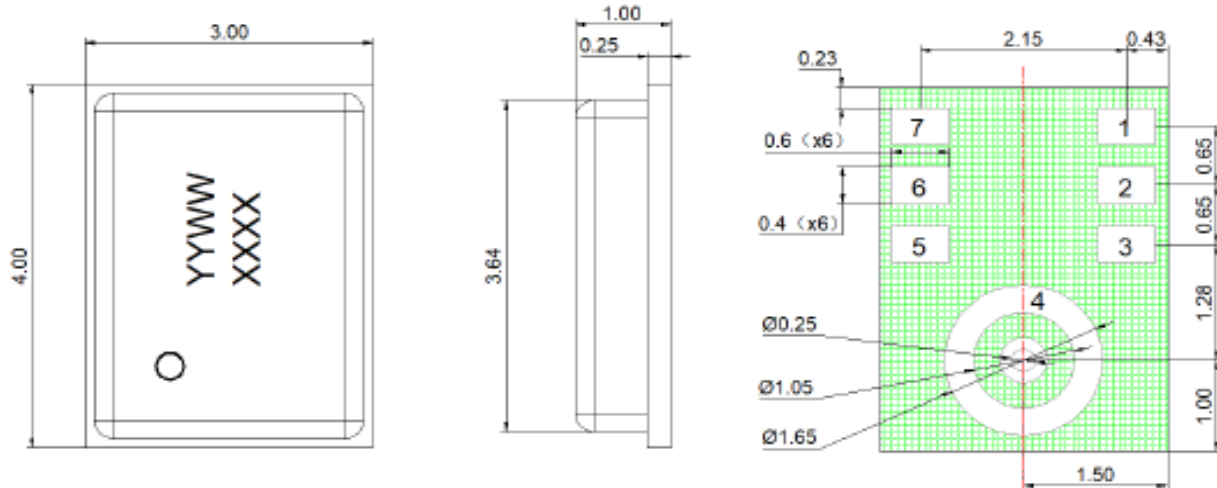

Data Code	
YYWW	YY:Year WW: Work Week
XXXX	XXXX: Lot No.

Item	Dimension	Tolerance(+/-)	Units
Length(L)	4.00	0.10	mm
Width(W)	3.00	0.10	mm
Height(H)	1.00	0.10	mm
Acoustic Port(AP)	Ø0.25	0.05	mm

Pin #	Pin Name	Type	Description
1	LR	Input	Left/Right channel select. When set low, the microphone outputs its signal in the left channel of the I ² S frame. When set high, the microphone outputs its signal in the right channel.
2	CONFIG	Input	Pull to ground. The state of this pin is used at power-up.
3	VDD	Power	Power, 1.62 to 3.63 V. This pin should be decoupled to GND with a 0.1 µF capacitor.
4	GND	Ground	Ground. Connect to ground on the PCB.
5	WS	Input	Serial Data-Word Select for I ² S Interface
6	SCK	Input	Serial Data Clock for I ² S Interface
7	SD	Output	Serial Data Output for I ² S Interface. This pin tri-states when not actively driving the appropriate output channel. The SD trace should have a 100 kΩ pull down resistor to discharge the line during the time that all microphones on the bus have tri-stated their outputs.

Notes:

All dimensions are in millimeter (mm).

Tolerance ±0.15mm unless otherwise specified.

Suggested Pickup Tool Location and Land Pattern*

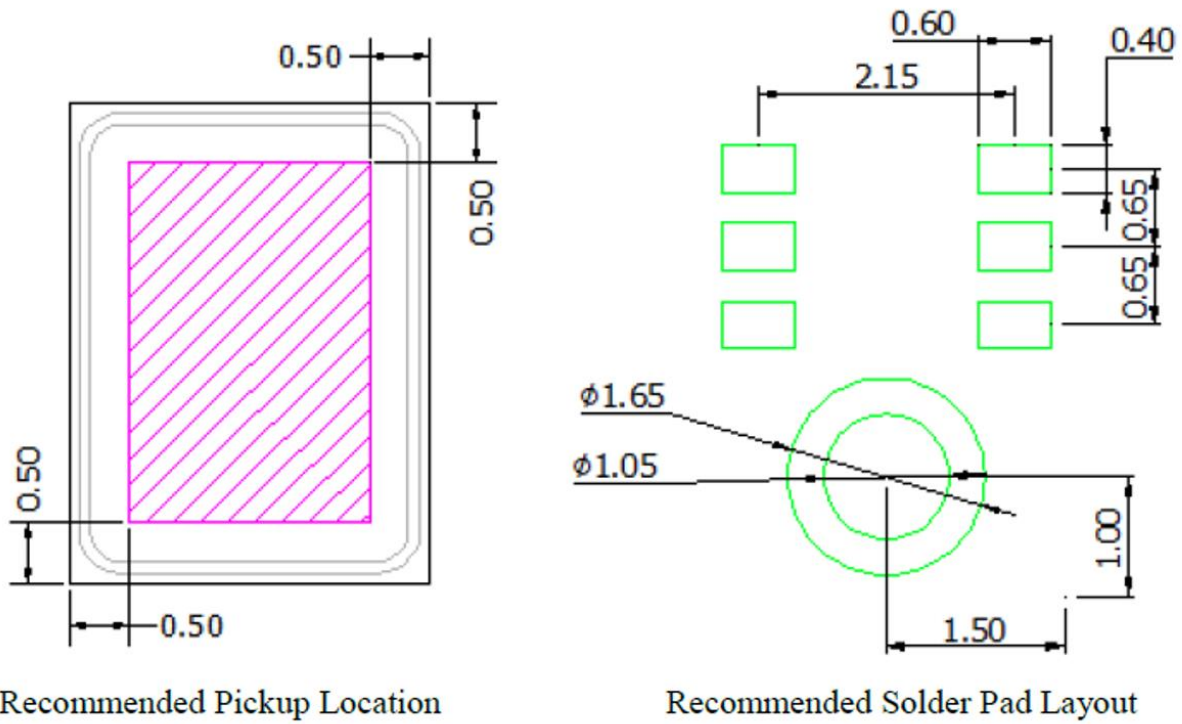

*This land pattern is advisory only and its use or adaptation is entirely voluntary. PUI Audio disclaims all liability of any kind associated with the use, application, or adaptation of this land pattern.

Packaging

Tape Specification

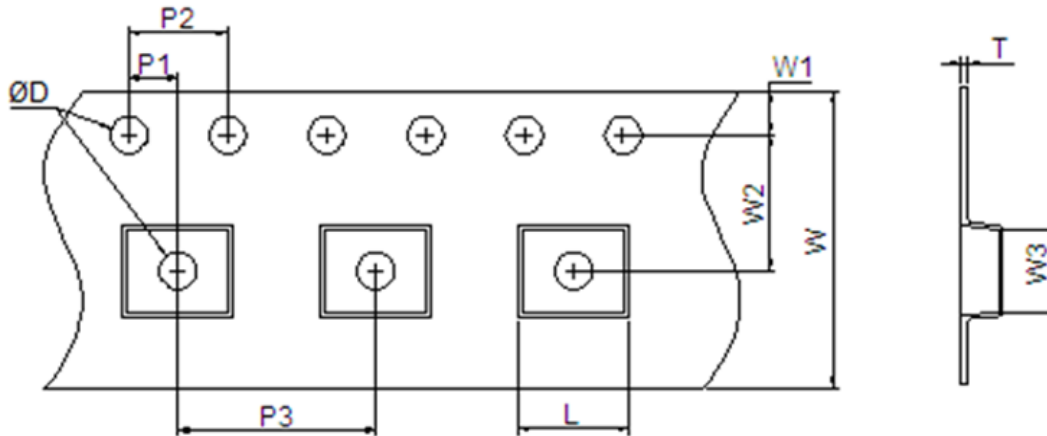

Symbol	Dimension		
	Minimum	Nominal	Maximum
$\varnothing D$	1.5	1.5	1.6
P1	1.9	2.0	2.1
P2	3.9	4.0	4.1
P3	7.9	8.0	8.1
L	4.0	4.1	4.2
W	11.7	12	12.3
W1	1.65	1.75	1.85
W2	5.4	5.5	5.6
W3	3.3	3.4	3.5
T	0.25	0.3	0.35

Notes

All dimensions are in millimeter (mm).
 Tolerance ± 0.15 mm unless otherwise specified.

Packaging (continued)

Reel Specification

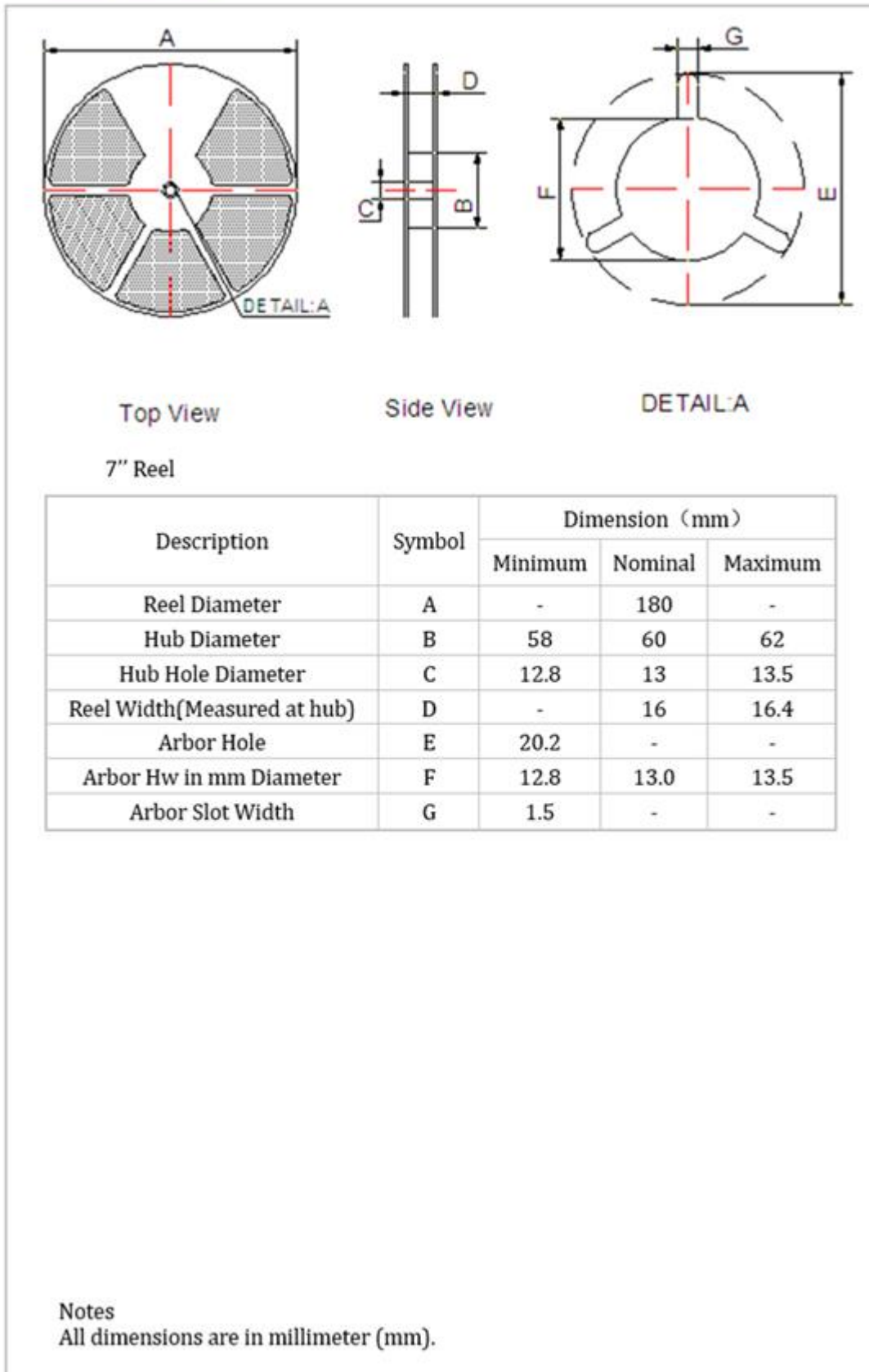

Packaging (continued)

Packing Quantity

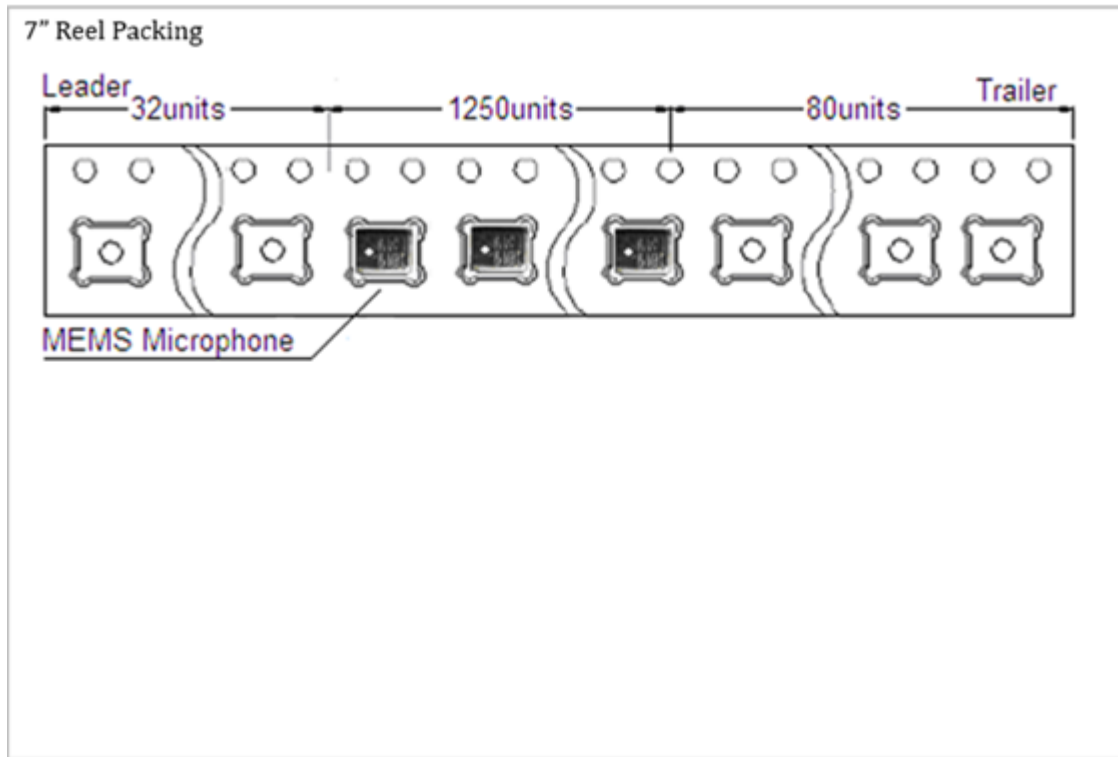

Packing Information

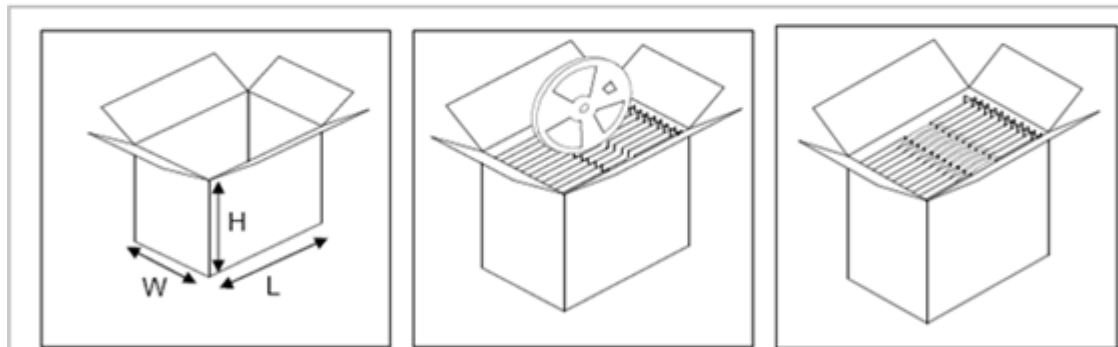

Tape & Reel 7"

Qty/reel	Weight/reel	Reel/Carton	Qty/carton	Weight full	Dimension carton Box	Storage
Pcs	Kg	Nos	Nos	Load(kg)	(LxWxH)mm	Temp
1250	0.25	4	5000	~3.00	272 x 159 x 236	-10°C~50 °C

Specifications Revisions

Revision	Description	Date
-	Released from Engineering	10/31/2019

Note:

1. Unless otherwise specified:
 - A. All dimensions are in millimeters.
 - B. Default tolerances are $\pm 0.5\text{mm}$ and angles are $\pm 3^\circ$.
2. Specifications subject to change or withdrawal without notice.