

THIS COPY IS PROVIDED ON A RESTRICTED BASIS AND IS NOT TO BE USED IN ANY WAY DETRIMENTAL TO THE INTERESTS OF PANDUIT CORP.

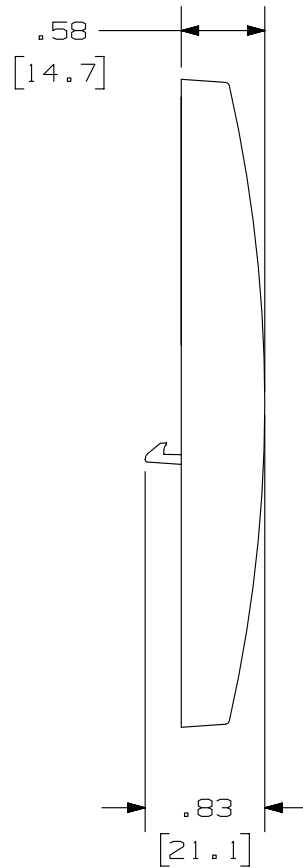
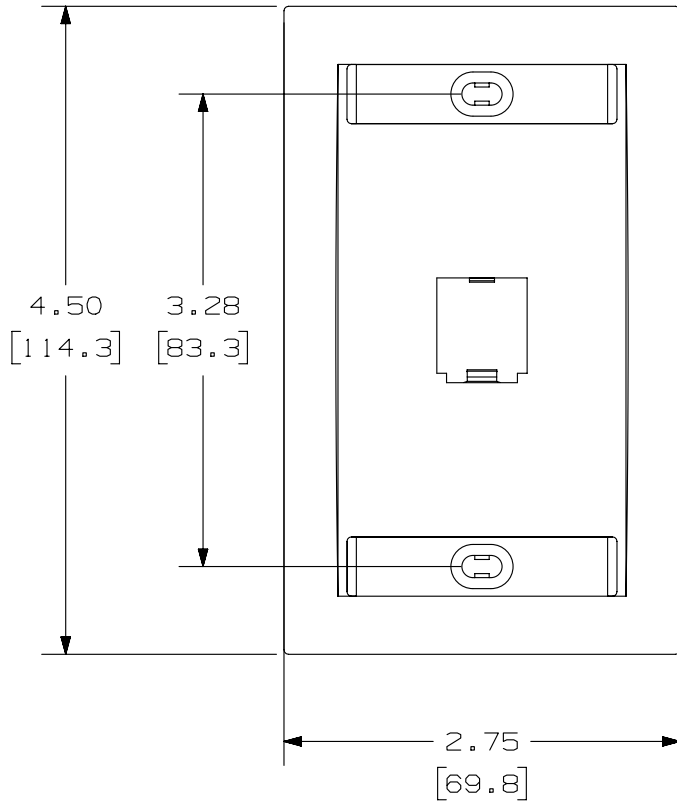

PANDUIT P/N	WEIGHT
CFPE1**Y	.70 LB/10 PCS (317.5 g/10 PCS)

NOTES:

- SEE CURRENT CATALOG FOR ADDITIONAL PART NUMBER SUFFIXES TO INDICATE COLOR AND OR PACKAGE QUANTITY.
- SEE CATALOG FOR COMPLETE LIST OF PARTS APPLICABLE FOR USE WITH THIS PART.
- DIMENSIONS IN [] ARE IN METRIC.
- PART INCLUDES:
 - 1- FACEPLATE
 - 2- LABEL
 - 2- LABEL COVER
 - 2- MOUNTING SCREW

PART NUMBER		CFPE1**Y	
TITLE		MINI-COM 1 POSITION EXECUTIVE FACEPLATE	
		CUSTOMER DRAWING	
ITEM REVISION NAME		D35147BB/00	
DATASET FILE NAME		D35147BB_DC02/00B	
UNLESS OTHERWISE SPECIFIED, DIMENSIONAL TOLERANCES ARE: IN (mm)		MATERIAL:	
.x ± .1 [2.54] .xxx ± .005 [.127]		ABS	
.xx ± .01 [.25] ANGLES ± 5 °		DRAWING NUMBER:	
THIRD ANGLE PROJECTION		35147-02	
DRAWN BY	DATE	CHK	SCALE
DW	6-7-95	CEF	NONE
SHT 1 OF 1		SIZE	
A		A	

REV	DATE	BY	CHK	APR	DESCRIPTION	ECN
1	4-14-14	MDJR	REFR	MMR	A. UPDATED TITLE BLOCK	35147-02
R	6-7-95	DW	CEF	CEF	RELEASED TO PRODUCTION	35147-02

D10100DA/14