



Extract from the online catalog

ST-REL4-KG 24/21-21

Order No.: 2823308



<http://eshop.phoenixcontact.de/phoenix/treeViewClick.do?UID=2823308>

Relay connector, fitted with miniature switching relay, contacts (AgNi):
Medium to large loads, 2 PDT, 24 V AC/DC input voltage, with light indicator, can be plugged into basic terminal blocks

Commercial data	
EAN	4017918077334
sales group	G014
Pack	10 pcs.
Customs tariff	85364190
Weight/Piece	0.05192 KG
Catalog page information	Page 89 (IF-2005)

Product notes

WEEE/RoHS-compliant since:
05/09/2006



<http://www.download.phoenixcontact.com>
Please note that the data given here has been taken from the online catalog. For comprehensive information and data, please refer to the user documentation. The General Terms and Conditions of Use apply to Internet downloads.

ST-REL4-KG 24/21-21 Order No.: 2823308
<http://eshop.phoenixcontact.de/phoenix/treeViewClick.do?UID=2823308>

Technical data

Coil side

Nominal input voltage U_N	24 V AC/DC
Input voltage range in reference to U_N	0.8 ... 1.1
Nominal input current at U_{IN}	17 mA
Typical response time	9 ms (with DC)
Typical release time	10 ms (with DC)
Operating voltage display	Yes
Protective circuit/component	Bridge rectifier, varistor

Contact side

Contact type	Single contact, 2-PDT
Contact material	AgNi
Maximum switching voltage	250 V AC/DC
Maximum inrush current	5 A
Limiting continuous current	3 A
Interrupting rating (ohmic load) max.	70 W (for 24 V DC)
	85 W (for 48 V DC)
	60 W (for 60 V DC)
	40 W (for 110 V DC)
	60 W (for 220 V DC)
	750 VA (for 250 V AC)

General data

Width	27 mm
Height	66.5 mm
Depth	33 mm
Test voltage relay winding/relay contact	2.5 kV AC (50 Hz, 1 min)
Test voltage PDT/PDT	1 kV AC (50 Hz, 1 min)
Ambient temperature (operation)	-20 °C ... 50 °C
Ambient temperature (storage/transport)	-20 °C ... 70 °C
Operating mode	100% operating factor
Service life mechanical	Approx. 2×10^7 cycles

ST-REL4-KG 24/21-21 Order No.: 2823308
<http://eshop.phoenixcontact.de/phoenix/treeViewClick.do?UID=2823308>

Standards/regulations	DIN VDE 0110b, Gr. C for 250 V DC
	IEC 60255/DIN VDE 0435 (in relevant parts)
	DIN EN 50178/DIN VDE 0160 (in relevant parts)
	EN 60730/DIN VDE 0631
	DIN VDE 0160 (in relevant parts)

Certificates / Approvals



Certification GOST

Diagrams/Drawings

Circuit diagram

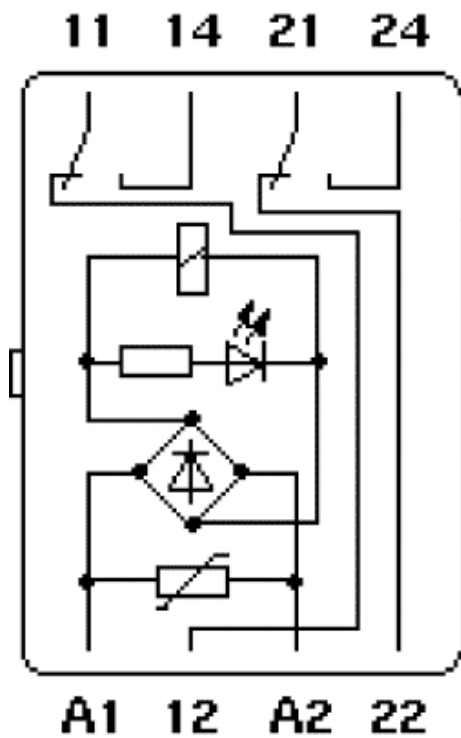

ST-REL4-KG 24/21-21 Order No.: 2823308
<http://eshop.phoenixcontact.de/phoenix/treeViewClick.do?UID=2823308>

Address

PHOENIX CONTACT Deutschland GmbH
Flachmarktstr. 8
32825 Blomberg, Germany
Phone +49 5235 3 12000
Fax +49 5235 3 41200
<http://www.phoenixcontact.de>



© 2010 Phoenix Contact
Technical modifications reserved;

onlinecomponents.com