



Extract from the online catalog

SACB-4/ 8-L-C SCO

Order No.: 1516797



<http://eshop.phoenixcontact.de/phoenix/treeViewClick.do?UID=1516797>

Sensor/actuator box, with SPEEDCON quick locking system and LED, with pluggable master cable connection and double-occupied slots, slots: 4

Commercial data	
EAN	4017918967529
Pack	1 pcs.
Customs tariff	85366990
Weight/Piece	0.2627 KG
Catalog page information	Page 116 (PC-2009)

Product notes

WEEE/RoHS-compliant since: 01/01/2008



<http://www.download.phoenixcontact.com>
Please note that the data given here has been taken from the online catalog. For comprehensive information and data, please refer to the user documentation. The General Terms and Conditions of Use apply to Internet downloads.

Technical data

General data	
Nominal voltage U_N	24 V DC
Max. operating voltage U_{max}	30 V DC
Max. current carrying capacity per path	2 A
Current carrying capacity per slot	4 A

SACB-4/ 8-L-C SCO Order No.: 1516797
<http://eshop.phoenixcontact.de/phoenix/treeViewClick.do?UID=1516797>

SACB total current	10 A
	2x 8 A (For electrical isolation)
Operating current of the indicator elements	≤ 5 mA
Number of positions	5
Number of slots	4
Degree of protection	IP65/IP67/IP69K
Inflammability class acc. to UL 94	V0
Ambient temperature (operation)	-30 °C ... 80 °C
Sensor/actuator connection system	M12-SPEEDCON-socket
Local diagnostics function	
Local diagnostics	Supply voltage per module LED green
	Status display I/O Yellow LED
Master cable data	
Type of connection	Pluggable screw connection
Conductor cross-section min. (signal)	0.14 mm ²
Conductor cross-section max. (signal)	1.5 mm ²
Conductor cross-section AWG min. (signal)	26
Conductor cross-section AWG max. (signal)	16
Conductor cross-section min. (energy)	0.14 mm ²
Conductor cross-section max. (energy)	1.5 mm ²
Conductor cross-section AWG min. (energy)	26
Conductor cross-section AWG max. (energy)	16
External cable diameter min.	7 mm
External cable diameter max.	12 mm
Stripping length	7 mm
Tightening torque, cover screw	0.35 Nm
Tightening torque, union nut	2.5 Nm
Tightening torque slot sensor/actuator cable	0.4 Nm
Tightening torque screw plug	0.4 Nm
Insulation material	
Housing material	PBT
Material of the moulding mass	PUR
Contact material	Cu alloy
Contact surface material	Gold-plated

SACB-4/ 8-L-C SCO Order No.: 1516797
http://eshop.phoenixcontact.de/phoenix/treeViewClick.do?UID=1516797

Contact carrier material	PA
Material of contact, master cable side	CU alloy
Material of contact surface, master cable side	Gold-plated
Material of the contact carrier on the master cable side	PA 66 V0
Material of threaded sleeve	Zinc die-cast
Material of threaded sleeve surface	Nickel-plated
Material, O-ring	NBR

Pin assignment

Slot/position = Wire color or connection	1 / 4 (A) = 1 / 4
	1 / 2 (B) = 1 / 2
	2 / 4 (A) = 2 / 4
	2 / 2 (B) = 2 / 2
	3 / 4 (A) = 3 / 4
	3 / 2 (B) = 3 / 2
	4 / 4 (A) = 4 / 4
	4 / 2 (B) = 4 / 2
	1-4 / 1 (+ 24 V) = U _N
	1-4 / 3 (0 V) = 0 V
	1-4 / 5 (PE) = PE

Certificates / Approvals



Certification CUL, UL

CUL

Nominal voltage U _N	24 V
Nominal current I _N	3 A

UL

Nominal voltage U _N	24 V
Nominal current I _N	3 A

SACB-4/ 8-L-C SCO Order No.: 1516797
<http://eshop.phoenixcontact.de/phoenix/treeViewClick.do?UID=1516797>

Drawings

Circuit diagram

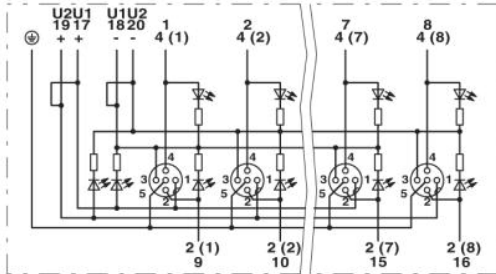

Schematic diagram

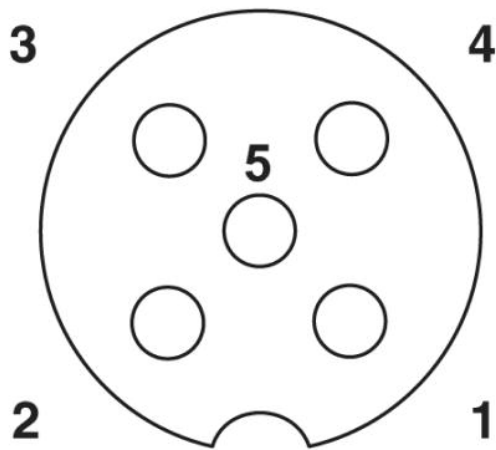

M12 slot, socket, 5-pos.

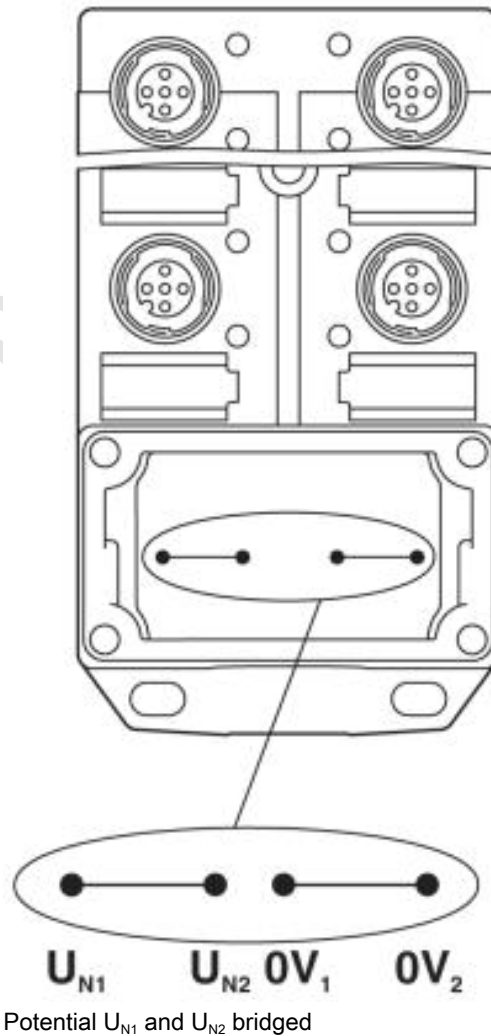

SACB-4/ 8-L-C SCO Order No.: 1516797

<http://eshop.phoenixcontact.de/phoenix/treeViewClick.do?UID=1516797>

Electrically isolated

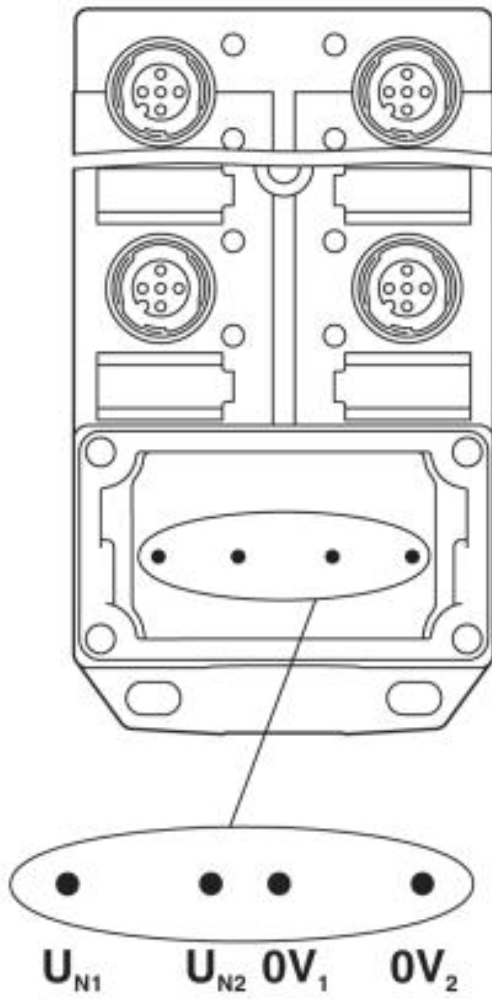

SACB-4/ 8-L-C SCO Order No.: 1516797
<http://eshop.phoenixcontact.de/phoenix/treeViewClick.do?UID=1516797>

Address

PHOENIX CONTACT GmbH & Co. KG
Flachsmarktstr. 8
32825 Blomberg, Germany
Phone +49 5235 3 00
Fax +49 5235 3 41200
<http://www.phoenixcontact.de>



© 2009 Phoenix Contact
Technical modifications reserved;

onlinecomponents.com