

Locking clip - SAC-M12-EXCLIP-F - 1558991

Please be informed that the data shown in this PDF Document is generated from our Online Catalog. Please find the complete data in the user's documentation. Our General Terms of Use for Downloads are valid (<http://phoenixcontact.com/download>)



Locking clip for the socket side of sensor/actuator cables with M12 connector and M12 connectors for assembly, for knurl diameter: 15 mm or for Allen key with a wrench size of 14 mm, prevents the disconnection of plug-in connections without tools

Key Commercial Data

Packing unit	10 STK
Minimum order quantity	10 STK
GTIN	 4 046356 299169

Technical data

Ambient conditions

Ambient temperature (operation)	-40 °C ... 90 °C (Locking clip)
	-40 °C ... 65 °C (for installation)
Ambient temperature (storage/transport)	-40 °C ... 105 °C

Material

Flammability rating according to UL 94	V0
Material	TPE-U

Standards and Regulations

Flammability rating according to UL 94	V0
--	----

Classifications

eCl@ss

eCl@ss 4.0	27060306
eCl@ss 4.1	27060306
eCl@ss 5.0	27061801
eCl@ss 5.1	27061801
eCl@ss 6.0	27061801
eCl@ss 7.0	27061801
eCl@ss 8.0	23159090

Locking clip - SAC-M12-EXCLIP-F - 1558991

Classifications

ETIM

ETIM 3.0	EC000464
ETIM 4.0	EC000464
ETIM 5.0	EC000464

UNSPSC

UNSPSC 6.01	31251501
UNSPSC 7.0901	31251501
UNSPSC 11	31251501
UNSPSC 12.01	31251501
UNSPSC 13.2	31251501

Drawings

Dimensional drawing

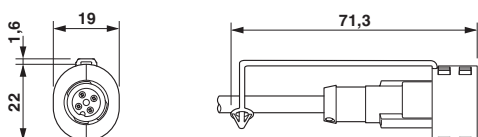

Locking clip mounted on straight M12 connector (not supplied as standard)

Dimensional drawing

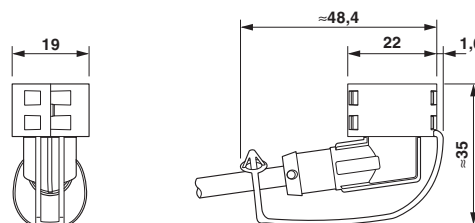

Locking clip mounted on angled M12 connector (not supplied as standard)

Dimensional drawing

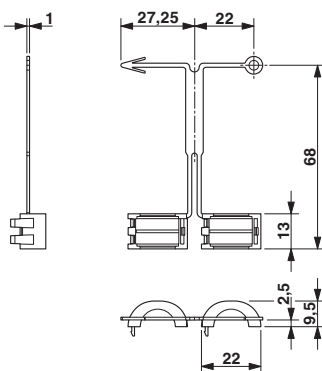

Phoenix Contact 2016 © - all rights reserved
<http://www.phoenixcontact.com>

PHOENIX CONTACT GmbH & Co. KG
Flachmarktstr. 8
32825 Blomberg
Germany
Tel. +49 5235 300
Fax +49 5235 3 41200
<http://www.phoenixcontact.com>