

# Locking clip - SAC-M12-EXCLIP-M - 1558988

Please be informed that the data shown in this PDF Document is generated from our Online Catalog. Please find the complete data in the user's documentation. Our General Terms of Use for Downloads are valid (<http://phoenixcontact.com/download>)



Locking clip for the pin side of sensor/actuator cables with M12 connector and M12 connectors for assembly, for knurl diameter: 15 mm or for Allen key with a wrench size of 14 mm, prevents the disconnection of plug-in connections without tools

## Key Commercial Data

Packing unit	10 STK
Minimum order quantity	10 STK
GTIN	 4 046356 299152

## Technical data

### Ambient conditions

Ambient temperature (operation)	-40 °C ... 65 °C (Locking clip)
	-40 °C ... 65 °C (for installation)
Ambient temperature (storage/transport)	-40 °C ... 105 °C

### Material

Flammability rating according to UL 94	V0
Material	TPE-U

### Standards and Regulations

Flammability rating according to UL 94	V0
--	----

## Classifications

### eCl@ss

eCl@ss 4.0	27060306
eCl@ss 4.1	27060306
eCl@ss 5.0	27061801
eCl@ss 5.1	27061801
eCl@ss 6.0	27061801
eCl@ss 7.0	27061801
eCl@ss 8.0	23159090

# Locking clip - SAC-M12-EXCLIP-M - 1558988

## Classifications

### ETIM

ETIM 3.0	EC000464
ETIM 4.0	EC000464
ETIM 5.0	EC000464

### UNSPSC

UNSPSC 6.01	31251501
UNSPSC 7.0901	31251501
UNSPSC 11	31251501
UNSPSC 12.01	31251501
UNSPSC 13.2	31251501

## Drawings

Dimensional drawing

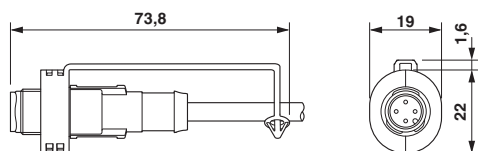

Locking clip mounted on straight M12 connector (not supplied as standard)

Dimensional drawing

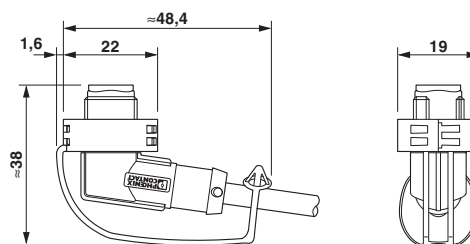

Locking clip mounted on angled M12 connector (not supplied as standard)

Dimensional drawing

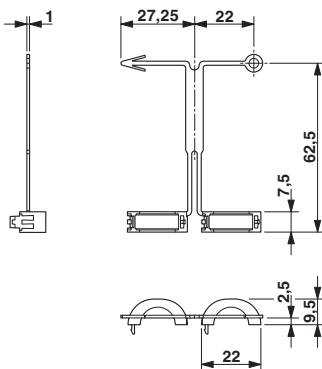

Phoenix Contact 2016 © - all rights reserved  
<http://www.phoenixcontact.com>

PHOENIX CONTACT GmbH & Co. KG  
Flachmarktstr. 8  
32825 Blomberg  
Germany  
Tel. +49 5235 300  
Fax +49 5235 3 41200  
<http://www.phoenixcontact.com>