

## Panel feed-through terminal block - PW 4-POT-SL/S - 3059744

Please be informed that the data shown in this PDF Document is generated from our Online Catalog. Please find the complete data in the user's documentation. Our General Terms of Use for Downloads are valid (<http://phoenixcontact.com/download>)



Panel feed-through terminal block, Connection method: Push-in connection, Solder connection, Load current : 32 A, Cross section: 0.2 mm<sup>2</sup> - 4 mm<sup>2</sup>, AWG 24 - 12, Width: 8.1 mm, Color: gray

### Product Features

- Tool-free wiring of conductors with ferrules or solid conductors from 0.34 mm<sup>2</sup>
- User-friendly Push-in connection
- Easy grouping with engagement pin versions
- Molded versions ensure maximum tightness of seal
- The integrated latch allows you to release connected conductors with any type of tool



### Key Commercial Data

Packing unit	1 pc
Minimum order quantity	50 pc
Weight per Piece (excluding packing)	9.6 g
Custom tariff number	85369010
Country of origin	China

### Technical data

#### General

Number of levels	1
Number of connections	2
Nominal cross section	4 mm <sup>2</sup>
Color	gray
Insulating material	PA
Flammability rating according to UL 94	V0
Maximum load current	41 A
Rated surge voltage	8 kV

## Panel feed-through terminal block - PW 4-POT-SL/S - 3059744

### Technical data

#### General

Degree of pollution	3
Overvoltage category	III
Insulating material group	I
Ambient temperature (operation)	-40 °C ... 105 °C
Connection in acc. with standard	IEC 60947-7-1
Nominal current I <sub>N</sub>	32 A
Maximum load current	32 A
Nominal voltage U <sub>N</sub>	800 V
Open side panel	No
Number of positions	1

#### Dimensions

Width	8.1 mm
Plate thickness	1 mm ... 4 mm

#### Connection data

Connection side	Outside
Connection method	Push-in connection
Conductor cross section solid min.	0.2 mm <sup>2</sup>
Conductor cross section solid max.	4 mm <sup>2</sup>
Conductor cross section flexible min.	0.2 mm <sup>2</sup>
Conductor cross section flexible max.	6 mm <sup>2</sup>
Conductor cross section AWG min.	24
Conductor cross section AWG max.	12
Conductor cross section flexible, with ferrule without plastic sleeve min.	0.25 mm <sup>2</sup>
Conductor cross section flexible, with ferrule without plastic sleeve max.	6 mm <sup>2</sup>
Conductor cross section flexible, with ferrule with plastic sleeve min.	0.25 mm <sup>2</sup>
Conductor cross section flexible, with ferrule with plastic sleeve max.	4 mm <sup>2</sup>
2 conductors with same cross section, stranded, TWIN ferrules with plastic sleeve, min.	0.5 mm <sup>2</sup>
2 conductors with same cross section, stranded, TWIN ferrules with plastic sleeve, max.	1 mm <sup>2</sup>
Stripping length	10 mm
Internal cylindrical gage	A4
Connection side	Inside
Connection method	Solder connection

#### Standards and Regulations

Connection in acc. with standard	UL
----------------------------------	----

# Panel feed-through terminal block - PW 4-POT-SL/S - 3059744

## Technical data

### Standards and Regulations

	IEC 60947-7-1
Flammability rating according to UL 94	V0

## Classifications

### eCl@ss

eCl@ss 4.0	27141131
eCl@ss 4.1	27141131
eCl@ss 5.0	27141134
eCl@ss 5.1	27141134
eCl@ss 6.0	27141134
eCl@ss 7.0	27141134
eCl@ss 8.0	27141134
eCl@ss 9.0	27141134

### ETIM

ETIM 4.0	EC001283
ETIM 5.0	EC001283

### UNSPSC

UNSPSC 6.01	30211811
UNSPSC 7.0901	39121410
UNSPSC 11	39121410
UNSPSC 12.01	39121410
UNSPSC 13.2	39121410

## Approvals

### Approvals

---

Approvals

UL Recognized

---

Ex Approvals

---

Approvals submitted

# Panel feed-through terminal block - PW 4-POT-SL/S - 3059744

## Approvals

### Approval details

UL Recognized			
	B	C	D
mm <sup>2</sup> /AWG/kcmil	24-10	24-10	24-10
Nominal current I <sub>N</sub>	30 A	30 A	5 A
Nominal voltage U <sub>N</sub>	300 V	300 V	600 V

## Drawings

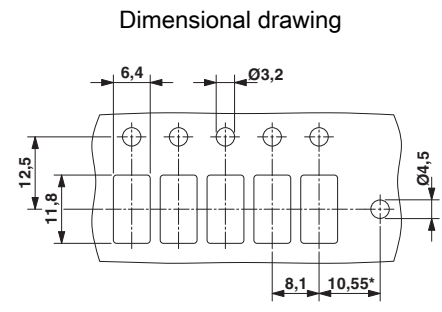
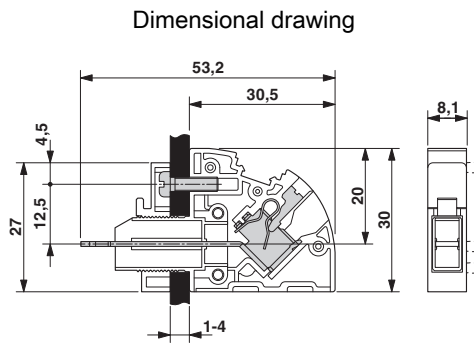

\*Only when using the PW 4-F flange plate