

## Electronic housing - EG 45-AG/ABS GN - 2907363

Please be informed that the data shown in this PDF Document is generated from our Online Catalog. Please find the complete data in the user's documentation. Our General Terms of Use for Downloads are valid (<http://phoenixcontact.com/download>)

Housing cover, closed



Illustration shows a fully mounted version of the electronic housing

### Product Features

- Tool-free mounting
- Fast snap-on mounting on symmetrical DIN rails according to EN 60715
- Date of manufacture and material and part identification embossed on the housing (recyclability)
- Functional and industry-oriented housing technology
- Optimum accommodation of electronic components with graded pitches with a design width of 22.5 mm, 45 mm, 67.5 mm, and 90 mm
- Practical and easy-to-wire conductor connection using extra finely stranded sturdy screw terminal blocks up to 2.5 mm<sup>2</sup>
- Shock and contamination-proof accommodation of electronic components (IP40 housing, IP20 terminal blocks)



### Key Commercial Data

Packing unit	1 pc
Minimum order quantity	10 pc
Weight per Piece (excluding packing)	15.07 g
Custom tariff number	85389099
Country of origin	Germany

### Technical data

#### General

Housing type	Component housing
Housing material	Acryl butadiene styrene (ABS)
Color	green

#### Ambient conditions

Ambient temperature (operation)	80 °C
---------------------------------	-------

# Electronic housing - EG 45-AG/ABS GN - 2907363

## Technical data

### Dimensions

Length	75 mm
Constructional height	17.5 mm
Width	45 mm

### Technical data

Flammability rating according to UL 94	HB
Number of positions	16

### Standards and Regulations

Flammability rating according to UL 94	HB
--	----

## Classifications

### eCl@ss

eCl@ss 4.0	27180401
eCl@ss 4.1	27180401
eCl@ss 5.0	27180506
eCl@ss 5.1	27180506
eCl@ss 6.0	27180802
eCl@ss 7.0	27182702
eCl@ss 8.0	27182702
eCl@ss 9.0	27182702

### ETIM

ETIM 2.0	EC001031
ETIM 3.0	EC001031
ETIM 4.0	EC001031
ETIM 5.0	EC001031

### UNSPSC

UNSPSC 6.01	31261501
UNSPSC 7.0901	31261501
UNSPSC 11	31261501
UNSPSC 12.01	31261501
UNSPSC 13.2	31261501

## Approvals

### Approvals

# Electronic housing - EG 45-AG/ABS GN - 2907363

## Approvals

Approvals

UL Recognized

---

Ex Approvals

---

Approvals submitted

---

## Approval details



## Drawings

Dimensional drawing

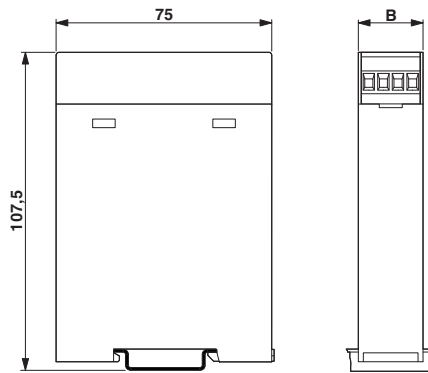

# Electronic housing - EG 45-AG/ABS GN - 2907363

Explosion drawing

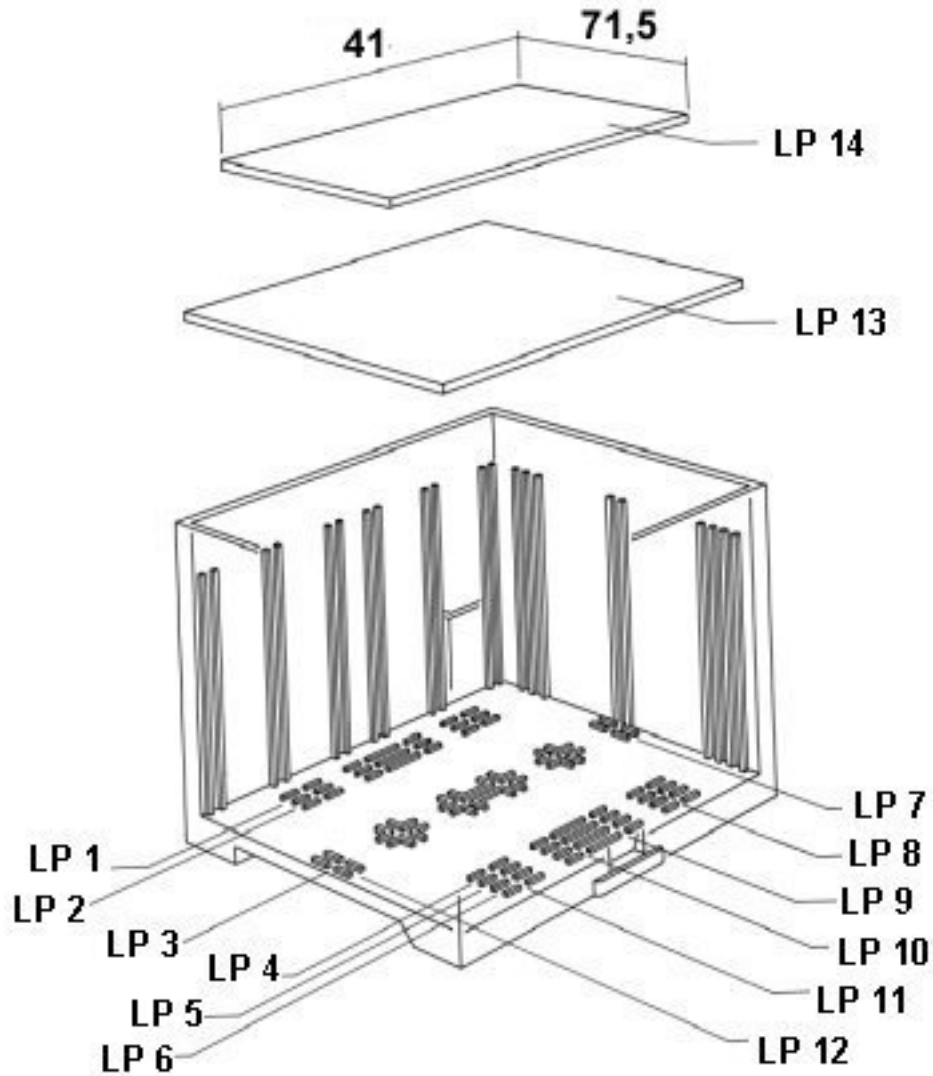

valid for PCB 13

# Electronic housing - EG 45-AG/ABS GN - 2907363

Explosion drawing

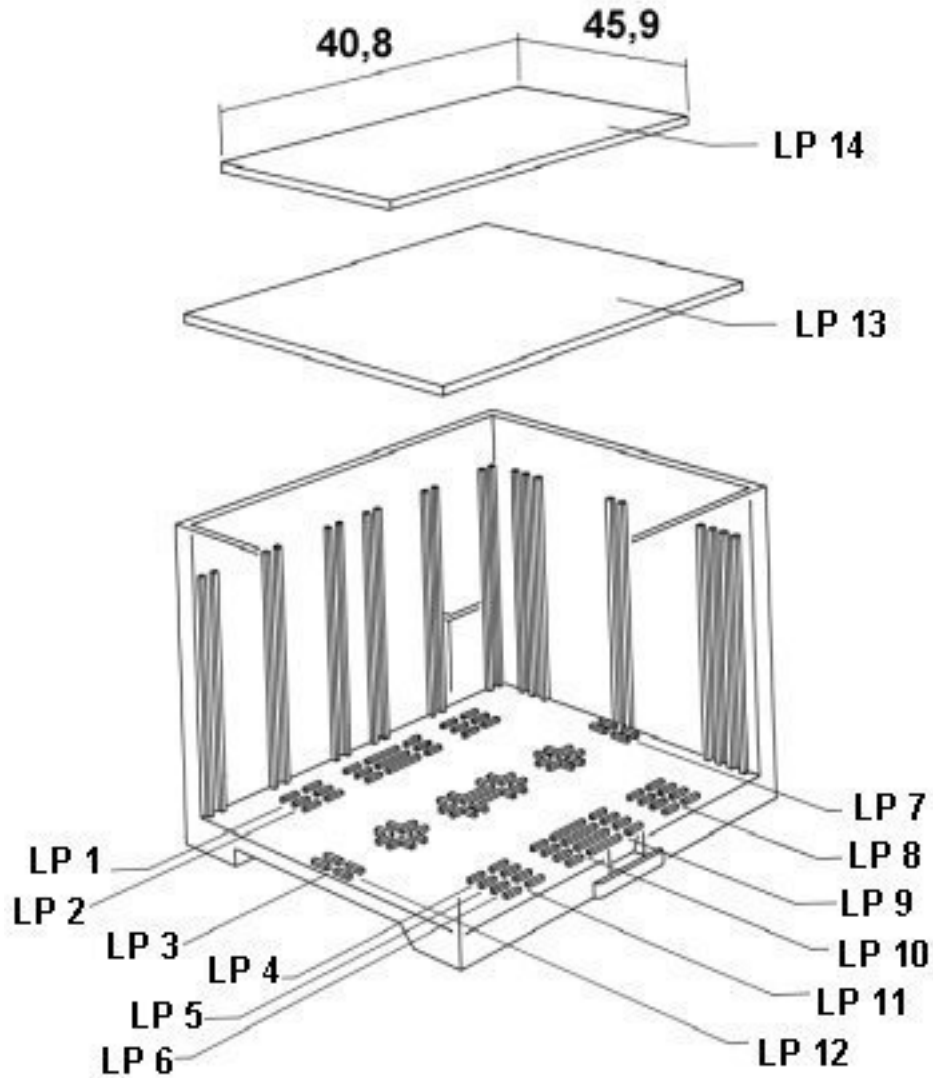

valid for PCB 14

# Electronic housing - EG 45-AG/ABS GN - 2907363

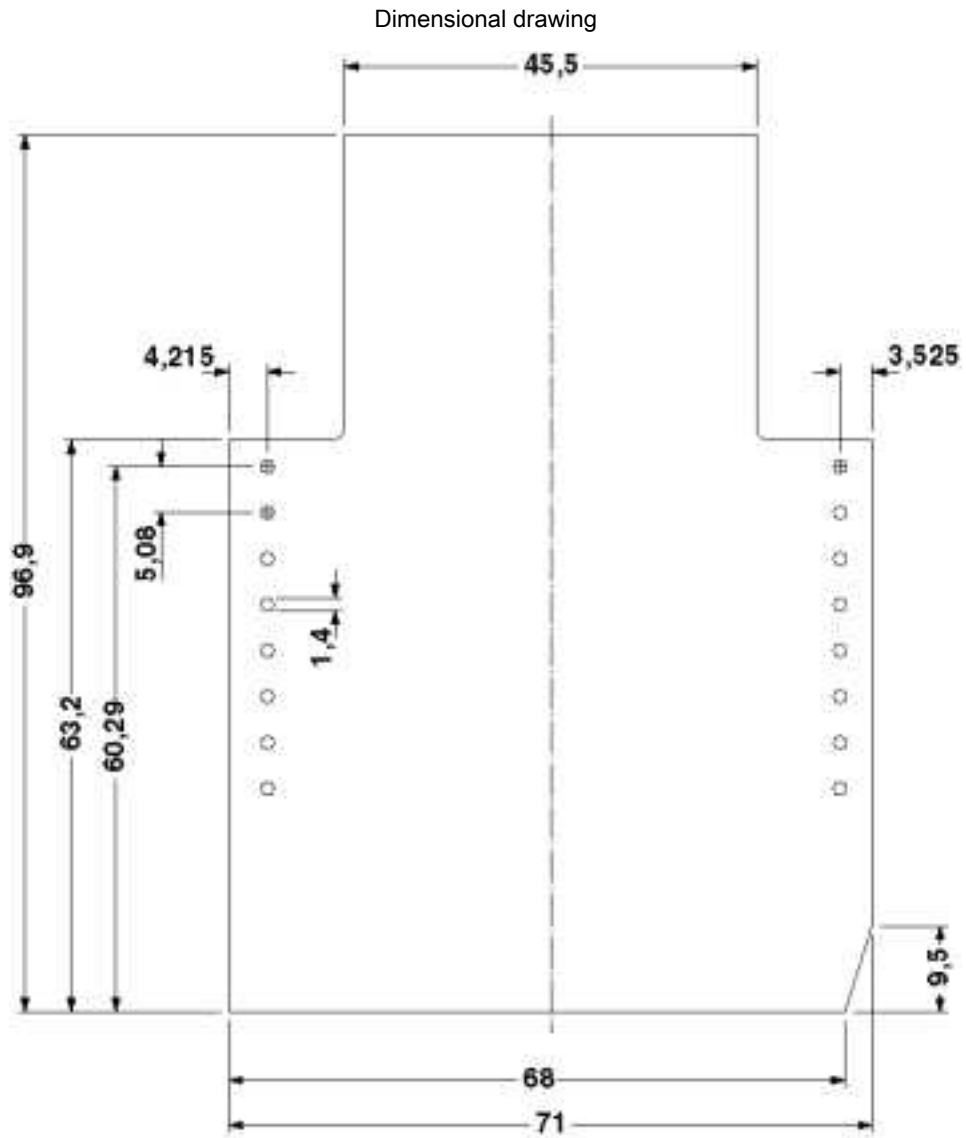

Component mounting side, if the double-level upper part is used

# Electronic housing - EG 45-AG/ABS GN - 2907363

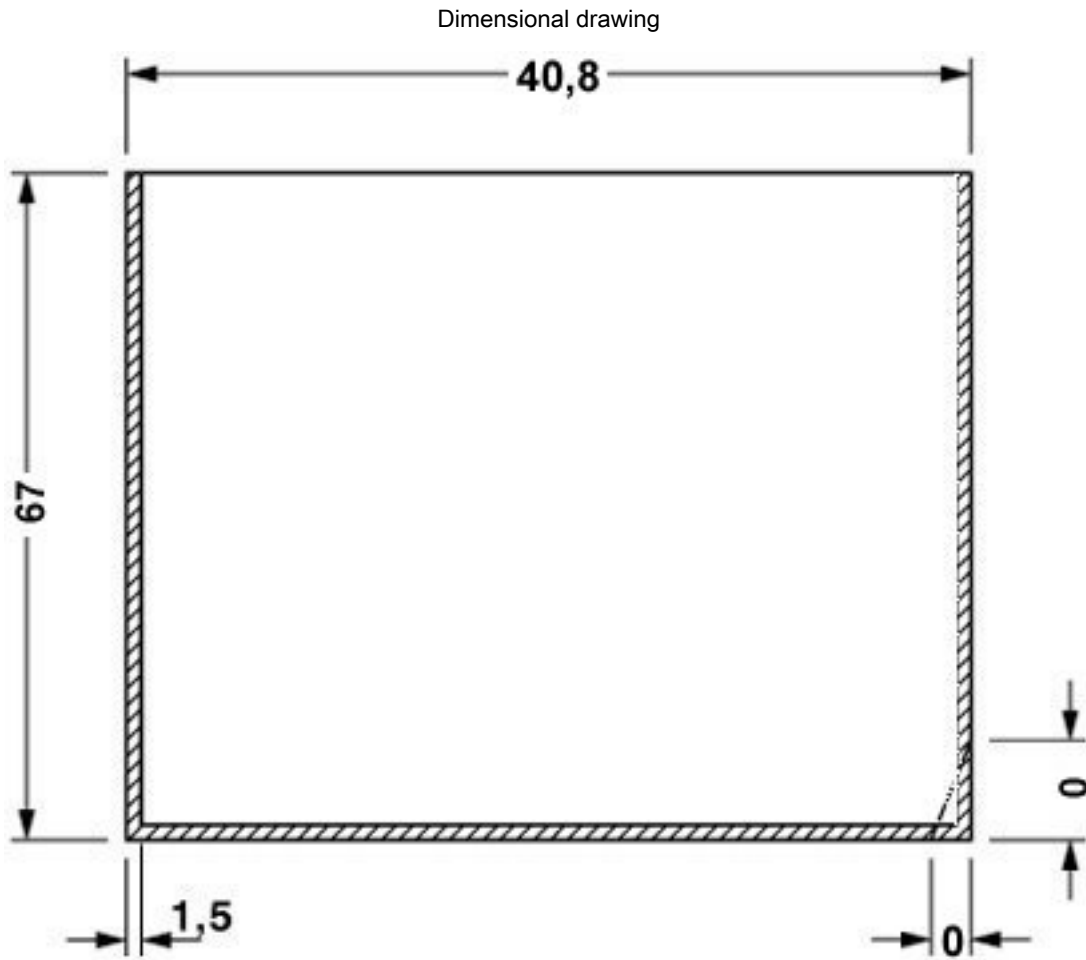

valid for PCB 1; 3; 5 and 6, see explosion drawing

# Electronic housing - EG 45-AG/ABS GN - 2907363

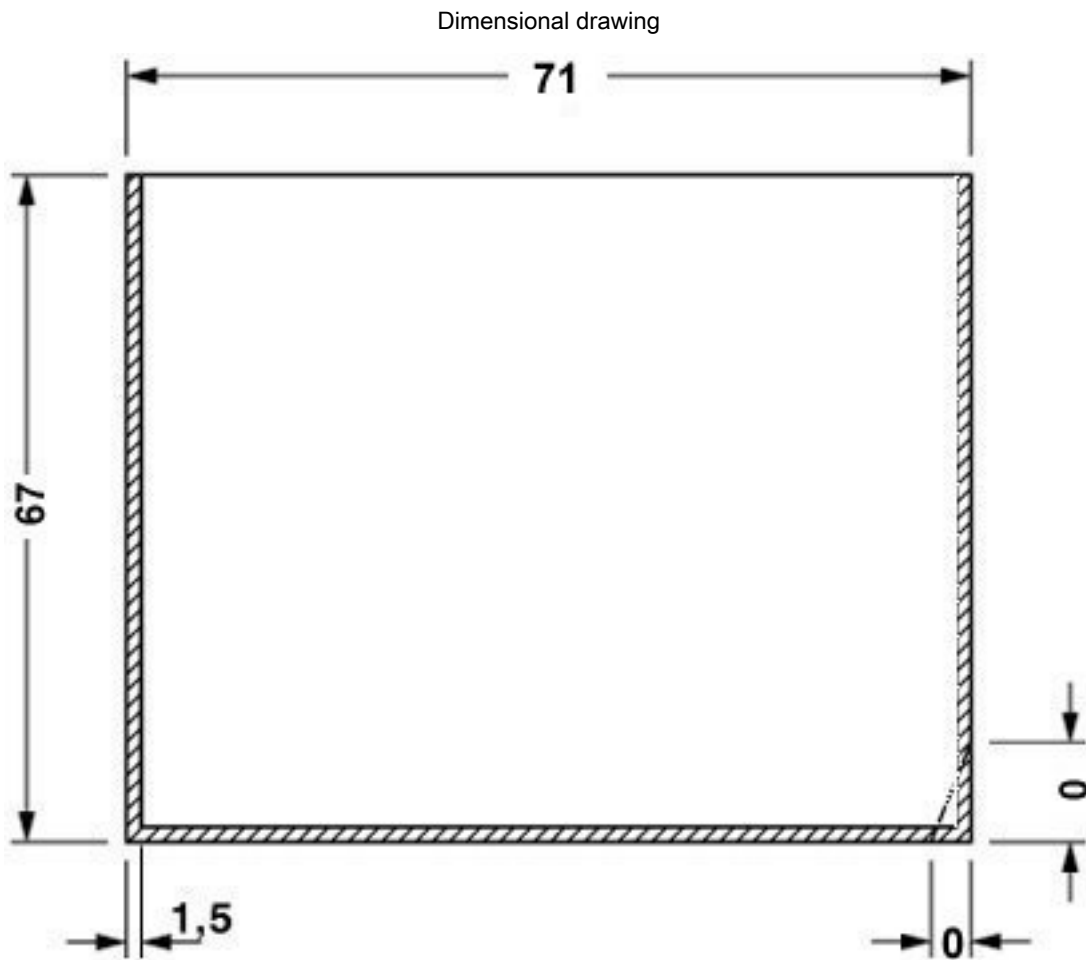

valid for PCB 7 and 12, see explosion drawing

## Electronic housing - EG 45-AG/ABS GN - 2907363

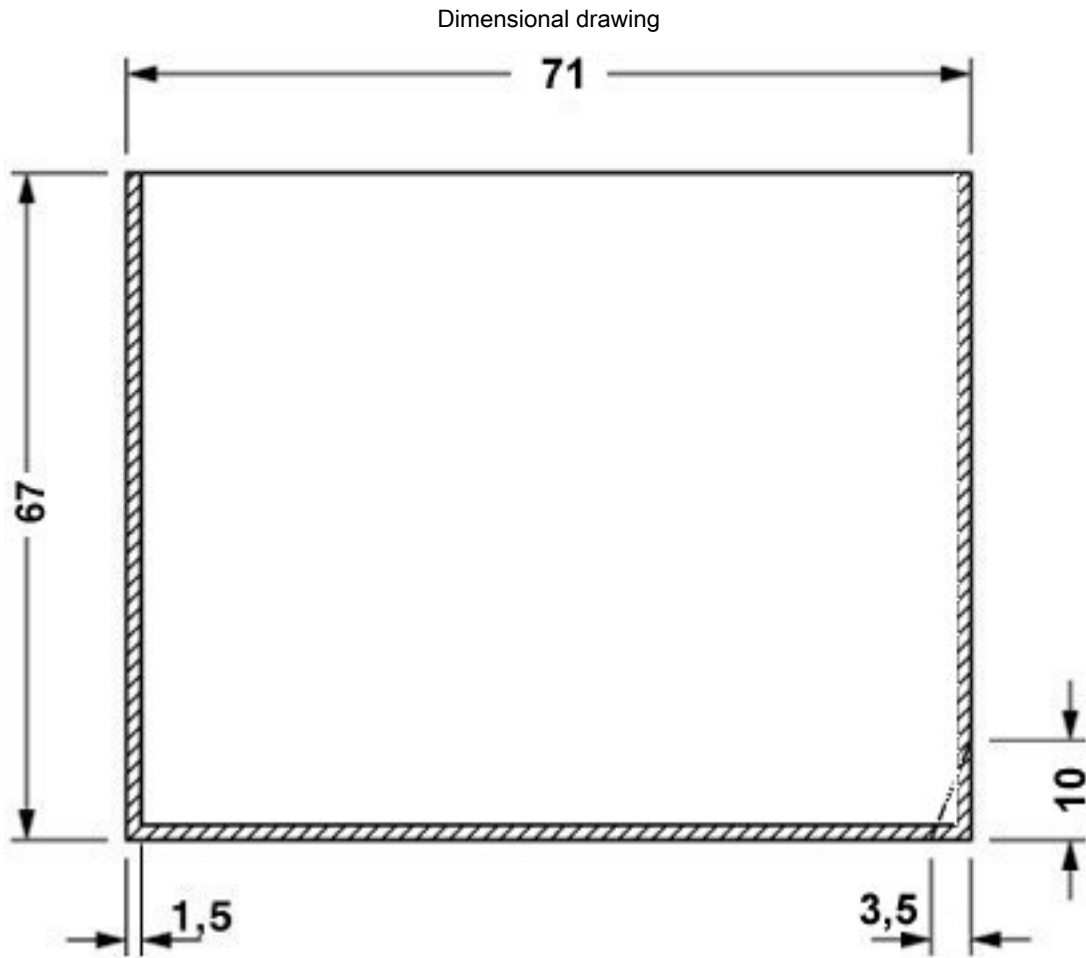

valid for PCB 10, see explosion drawing