

Hybrid motor starter - ELR H3-SC-230AC/500AC-9 - 2900531

Please be informed that the data shown in this PDF Document is generated from our Online Catalog. Please find the complete data in the user's documentation. Our General Terms of Use for Downloads are valid (<http://phoenixcontact.com/download>)



Hybrid motor starter for starting 3~ AC motors up to 550 V AC, with 230 V AC input, 9 A output current.

Why buy this product

- 22.5 mm wide
- Low-wear switching
- Space saving
- Long service life
- 3-phase loop bridges



Key Commercial Data

Packing unit	1 STK
GTIN	 4 046356 525985
GTIN	4046356525985
Weight per Piece (excluding packing)	220.000 g
Custom tariff number	85371098
Country of origin	Germany

Technical data

Device supply

Rated control circuit supply voltage U_s	230 V AC
Control supply voltage range	85 V AC ... 253 V AC
Rated control supply current I_s	4 mA
Mains frequency	50/60 Hz
Type of protection	Surge protection

Hybrid motor starter - ELR H3-SC-230AC/500AC-9 - 2900531

Technical data

Input data

Input name	Control input
Rated actuating voltage U_c	230 V AC
Triggering voltage range	85 V AC ... 253 V AC
Rated actuating current I_c	7 mA (Input type 1)
Mains frequency	50/60 Hz
Switching threshold	44 V AC ("0" signal)
	85 V AC ("1" signal)
Typical turn-off time	< 70 ms

Output data load output

Output name	AC output
Rated operating voltage U_e	500 V AC
Operating voltage range	42 V AC ... 550 V AC
Rated operating current I_e	9 A (AC-51)
	6.5 A (AC-53a)
Mains frequency	50/60 Hz
Load current range	0 A ... 9 A (see to derating)
Trigger characteristic in acc. with IEC 60947-4-2	-
Leakage current	0 mA
Type of protection	Surge protection

General

Switching frequency	≤ 2 Hz (Load-dependent)
Mounting position	vertical (horizontal DIN rail, motor output below)
Mounting type	DIN rail mounting
Assembly instructions	alignable, for spacing see derating
Operating mode	100% operating factor
Maximum power dissipation	7 W
Minimum power dissipation	0.88 W
Operating voltage display	Green LED
Status display	Yellow LED

Connection data, input side

Connection name	Control circuits
Connection method	Screw connection
Stripping length	8 mm
Screw thread	M3
Conductor cross section solid	0.2 mm ² ... 2.5 mm ²
Conductor cross section flexible	0.2 mm ² ... 2.5 mm ²

Hybrid motor starter - ELR H3-SC-230AC/500AC-9 - 2900531

Technical data

Connection data, input side

Conductor cross section AWG	24 ... 14
Torque	0.5 Nm ... 0.6 Nm

Connection data, output side

Connection name	Load circuit
Connection method	Screw connection
Stripping length	8 mm
Screw thread	M3
Conductor cross section solid	0.2 mm ² ... 2.5 mm ²
Conductor cross section flexible	0.2 mm ² ... 2.5 mm ²
Conductor cross section AWG	24 ... 14
Torque	0.5 Nm ... 0.6 Nm

Ambient conditions

Ambient temperature (operation)	-25 °C ... 70 °C (observe derating)
Ambient temperature (storage/transport)	-40 °C ... 80 °C
Degree of protection	IP20

Dimensions

Width	22.5 mm
Height	106.6 mm
Depth	113.7 mm

UL data

SCCR	100 kA (500 V AC (fuse: 30 A class CC/30 A class J (high fault)))
	5 kA (500 V AC (fuse: 20 A RK5 (standard fault)))
FLA	6.5 A (500 V AC)
Group installation	20 A (class RK5, SCCR 5kA, #24 - 14 AWG max. solid and stranded)
	30 A (class CC or J, SCCR 100kA, #24 - 14 AWG max, solid and stranded)
Category code	NLDX / NRNT

Insulation characteristics

Rated insulation voltage	500 V
Rated surge voltage	4 kV
Overvoltage category	III
Degree of pollution	2
Designation	Insulation characteristics between the control input and control supply voltage, and auxiliary circuit to the main circuit
Insulation	Safe isolation (IEC 60947-1/EN 50178) at operating voltage ≤ 300 V AC
	Basic isolation (IEC 60947-1) at operating voltage 300 ... 500 V AC

Hybrid motor starter - ELR H3-SC-230AC/500AC-9 - 2900531

Technical data

Insulation characteristics

	Safe isolation (EN 50178) at operating voltage 300 ... 500 V AC
Designation	Isolation characteristics between the control input and control supply voltage to auxiliary circuit
Insulation	Safe isolation (IEC 60947-1) in the auxiliary circuit \leq 300 V AC
	Safe isolation (EN 50178) in the auxiliary circuit \leq 300 V AC

Standards and Regulations

Designation	Standards/regulations
Standards/regulations	IEC 60947-1
	IEC 60947-4-2
	IEC 61508
	ISO 13849

Approvals/conformities

UL certificate	NLDX.E228652
----------------	--------------

Environmental Product Compliance

China RoHS	Environmentally Friendly Use Period = 50
	For details about hazardous substances go to tab "Downloads", Category "Manufacturer's declaration"

Drawings

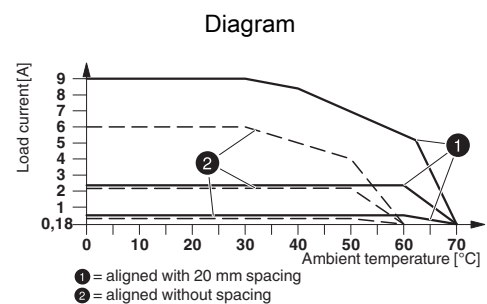
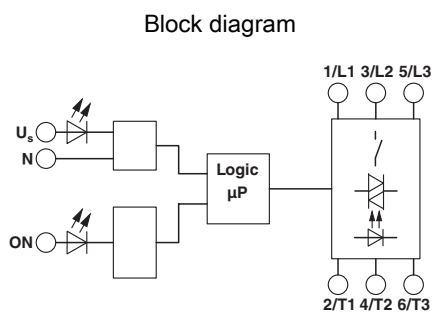

Derating diagram

Classifications

eCl@ss

eCl@ss 5.0	27024002
eCl@ss 5.1	27024002
eCl@ss 6.0	27024002
eCl@ss 7.0	27024002

Hybrid motor starter - ELR H3-SC-230AC/500AC-9 - 2900531

Classifications

eCl@ss

eCl@ss 8.0	27024002
eCl@ss 9.0	27024002

ETIM

ETIM 2.0	EC001037
ETIM 3.0	EC001037
ETIM 4.0	EC001037
ETIM 5.0	EC001037
ETIM 6.0	EC001037

UNSPSC

UNSPSC 6.01	30211915
UNSPSC 7.0901	39121514
UNSPSC 11	39121514
UNSPSC 12.01	39121514
UNSPSC 13.2	25173902

Approvals

Approvals

Approvals

UL Listed / cUL Listed / IECCE CB Scheme / UL Listed / cUL Listed / EAC / CCC-s / cULus Listed

Ex Approvals

Approval details

UL Listed		http://database.ul.com/cgi-bin/XYV/template/LISEXT/1FRAME/index.htm	FILE E 228652
-----------	---	---	---------------

cUL Listed		http://database.ul.com/cgi-bin/XYV/template/LISEXT/1FRAME/index.htm	FILE E 228652
------------	---	---	---------------

Hybrid motor starter - ELR H3-SC-230AC/500AC-9 - 2900531

Approvals

IECEE CB Scheme		http://www.iecee.org/	DE1-55728
-----------------	--	---	-----------

UL Listed		http://database.ul.com/cgi-bin/XYVV/template/LISEXT/1FRAME/index.htm	FILE E 323771
-----------	--	---	---------------

cUL Listed		http://database.ul.com/cgi-bin/XYVV/template/LISEXT/1FRAME/index.htm	FILE E 323771
------------	--	---	---------------

EAC			RU C- DE.A*30.B.01082
-----	--	--	--------------------------

CCC-s		http://www.china-certification.com	2016010304871315
-------	--	---	------------------

cULus Listed			
--------------	--	--	--

Accessories

Accessories

Bridge

Jumper - BRIDGE- 4-3M - 2901659



3-phase loop bridge for 4 CONTACTRON modules, with screw connection and 22.5 mm housing width, connecting cable: 3 m, with ferrules included.

Cover

Hybrid motor starter - ELR H3-SC-230AC/500AC-9 - 2900531

Accessories

Covering hood - BRIDGE COVER - 2906240



The BRIDGE COVER covering hood is used to cover unused plugs on the CONTACTRON bridge that may subsequently be used to extend the system. The hood can be used with the screw and Push-in version of the bridge.

Device marking

Plastic label - US-EMLP (15X5) - 0828790



Plastic label, Card, white, unlabeled, can be labeled with: THERMOMARK PRIME, THERMOMARK CARD, mounting type: adhesive, lettering field size: 15 x 5 mm

Plastic label - UC-EMLP (15X5) - 0819301



Plastic label, Sheet, white, unlabeled, can be labeled with: BLUEMARK CLED, BLUEMARK LED, CMS-P1-PLOTTER, PLOTMARK, mounting type: adhesive, lettering field size: 15 x 5 mm

Loop bridge

Jumper - BRIDGE- 2 - 2900746



3-phase loop bridge for 2 CONTACTRON modules, with screw connection and 22.5 mm housing width, connecting cable: 0.3 m, with ferrules.

Jumper - BRIDGE- 3 - 2900747



3-phase loop bridge for 3 CONTACTRON modules, with screw connection and 22.5 mm housing width, connecting cable: 0.3 m, with ferrules.

Hybrid motor starter - ELR H3-SC-230AC/500AC-9 - 2900531

Accessories

Jumper - BRIDGE- 4 - 2900748



3-phase loop bridge for 4 CONTACTRON modules, with screw connection and 22.5 mm housing width, connecting cable: 0.3 m, with ferrules.

Jumper - BRIDGE- 5 - 2900749



3-phase loop bridge for 5 CONTACTRON modules, with screw connection and 22.5 mm housing width, connecting cable: 0.3 m, with ferrules.

Jumper - BRIDGE- 6 - 2900750



3-phase loop bridge for 6 CONTACTRON modules, with screw connection and 22.5 mm housing width, connecting cable: 0.3 m, with ferrules.

Jumper - BRIDGE- 7 - 2900751



3-phase loop bridge for 7 CONTACTRON modules, with screw connection and 22.5 mm housing width, connecting cable: 0.3 m, with ferrules.

Jumper - BRIDGE- 8 - 2900752



3-phase loop bridge for 8 CONTACTRON modules, with screw connection and 22.5 mm housing width, connecting cable: 0.3 m, with ferrules.

Hybrid motor starter - ELR H3-SC-230AC/500AC-9 - 2900531

Accessories

Jumper - BRIDGE- 9 - 2900753



3-phase loop bridge for 9 CONTACTRON modules, with screw connection and 22.5 mm housing width, connecting cable: 0.3 m, with ferrules.

Jumper - BRIDGE-10 - 2900754



3-phase loop bridge for 10 CONTACTRON modules, with screw connection and 22.5 mm housing width, connecting cable: 0.3 m, with ferrules.

Jumper - BRIDGE- 2-3M - 2901543



3-phase loop bridge for 2 CONTACTRON modules, with screw connection and 22.5 mm housing width, connecting cable: 3 m, with ferrules included.

Jumper - BRIDGE- 3-3M - 2901656



3-phase loop bridge for 3 CONTACTRON modules, with screw connection and 22.5 mm housing width, connecting cable: 3 m, with ferrules included.

Jumper - BRIDGE- 5-3M - 2901545



3-phase loop bridge for 5 CONTACTRON modules, with screw connection and 22.5 mm housing width, connecting cable: 3 m, with ferrules included.

Hybrid motor starter - ELR H3-SC-230AC/500AC-9 - 2900531

Accessories

Jumper - BRIDGE- 6-3M - 2901697



3-phase loop bridge for 6 CONTACTRON modules, with screw connection and 22.5 mm housing width, connecting cable: 3 m, with ferrules included.

Jumper - BRIDGE- 7-3M - 2901698



3-phase loop bridge for 7 CONTACTRON modules, with screw connection and 22.5 mm housing width, connecting cable: 3 m, with ferrules included.

Jumper - BRIDGE- 8-3M - 2901700



3-phase loop bridge for 8 CONTACTRON modules, with screw connection and 22.5 mm housing width, connecting cable: 3 m, with ferrules included.

Jumper - BRIDGE- 9-3M - 2901701



3-phase loop bridge for 9 CONTACTRON modules, with screw connection and 22.5 mm housing width, connecting cable: 3 m, with ferrules included.

Jumper - BRIDGE-10-3M - 2901702



3-phase loop bridge for 10 CONTACTRON modules, with screw connection and 22.5 mm housing width, connecting cable: 3 m, with ferrules included.

Hybrid motor starter - ELR H3-SC-230AC/500AC-9 - 2900531

Accessories

Jumper - BRIDGE- 2-1M - 2901542



3-phase loop bridge for 2 modules from the CONTACTRON family with screw connection and 22.5 mm housing width, 1 m long connecting cable, without ferrules.

Jumper - BRIDGE- 3-1M - 2901655



3-phase loop bridge for 3 modules from the CONTACTRON family with screw connection and 22.5 mm housing width, 1 m long connecting cable, without ferrules.

Jumper - BRIDGE- 4-1M - 2901658



3-phase loop bridge for 4 modules from the CONTACTRON family with screw connection and 22.5 mm housing width, 1 m long connecting cable, without ferrules.

Jumper - BRIDGE- 5-1M - 2901544



3-phase loop bridge for 5 modules from the CONTACTRON family with screw connection and 22.5 mm housing width, 1 m long connecting cable, without ferrules.

Jumper - BRIDGE- 6-1M - 2901649



3-phase loop bridge for 6 modules in the CONTACTRON family with 1 m long connecting cable without ferrules, 22.5 mm housing width.
