

Front plate - VS-SI-FP-BP



1656657

<https://www.phoenixcontact.com/pc/products/1656657>

Please be informed that the data shown in this PDF document is generated from our Online Catalog. Please find the complete data in the user documentation. Our General Terms of Use for Downloads are valid.

Front plate, material: PBT



Commercial Data

Item number	1656657
Packing unit	1 pc
Minimum order quantity	1 pc
Product Key	BF7ECX
Catalog Page	Page 711 (C-2-2019)
GTIN	4046356030021
Weight per Piece (including packing)	20.1 g
Weight per Piece (excluding packing)	18.4 g
Customs tariff number	39269097
Country of origin	DE

Front plate - VS-SI-FP-BP

1656657

<https://www.phoenixcontact.com/pc/products/1656657>



Technical Data

Product properties

Product type	Data front plate
--------------	------------------

Dimensions

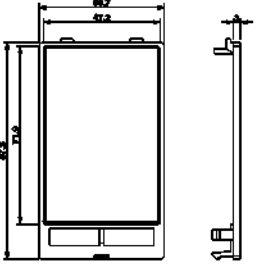
Dimensional drawing	
Width	51 mm
Height	12 mm
Length	87.5 mm

Material specifications

Color	gray
Flammability rating according to UL 94	V0
Housing material	PBT

Environmental and real-life conditions

Ambient conditions

Degree of protection	IP20
Ambient temperature (operation)	-10 °C ... 60 °C

Mounting

Assembly instructions	suitable for all mounting frames
-----------------------	----------------------------------

Front plate - VS-SI-FP-BP

1656657

<https://www.phoenixcontact.com/pc/products/1656657>



Drawings

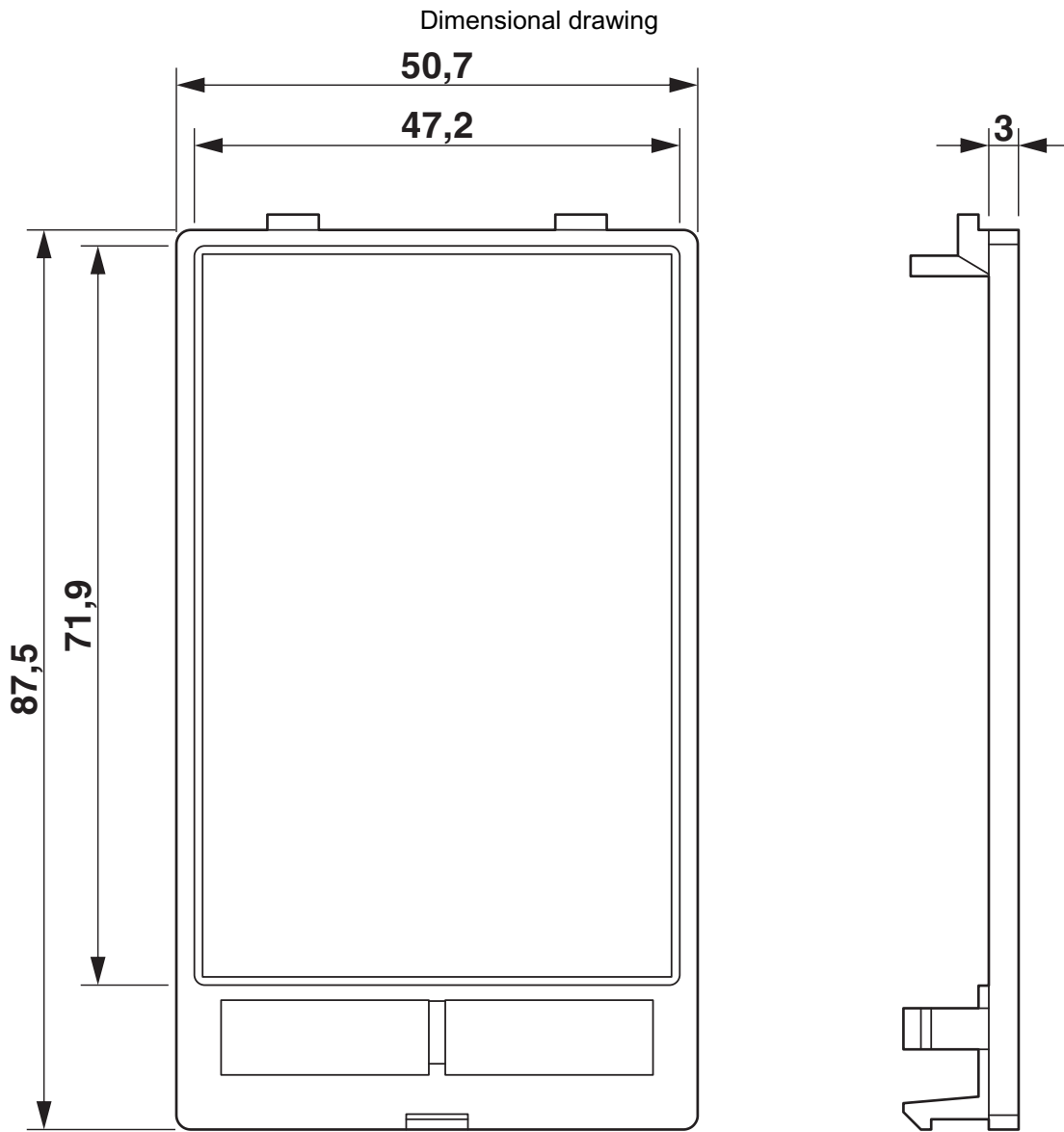

Dummy plate

Front plate - VS-SI-FP-BP

1656657

<https://www.phoenixcontact.com/pc/products/1656657>



Classifications

ECLASS

ECLASS-9.0	27189217
ECLASS-10.0.1	27182806
ECLASS-11.0	27182806

ETIM

ETIM 8.0	EC000456
----------	----------

UNSPSC

UNSPSC 21.0	39121300
-------------	----------

Front plate - VS-SI-FP-BP

1656657

<https://www.phoenixcontact.com/pc/products/1656657>



Environmental Product Compliance

China RoHS	Environmentally friendly use period: unlimited = EFUP-e
	No hazardous substances above threshold values

Front plate - VS-SI-FP-BP

1656657

<https://www.phoenixcontact.com/pc/products/1656657>



Accessories

Marker labels

Marker labels - VS-SI-BZ - 1656660

<https://www.phoenixcontact.com/pc/products/1656660>

Marker label, plastic, plate with 20 labels



Phoenix Contact 2023 © - all rights reserved
<https://www.phoenixcontact.com>

PHOENIX CONTACT GmbH & Co. KG
Flachsmarktstraße 8
D-32825 Blomberg
+49 (0) 5235-3 00
info@phoenixcontact.com