

## D-SUB contact support - VS-15-BU-DSUB-3P-LH - 1655328

Please be informed that the data shown in this PDF Document is generated from our Online Catalog. Please find the complete data in the user's documentation. Our General Terms of Use for Downloads are valid (<http://phoenixcontact.com/download>)

D-SUB contact carrier, shell size 2, accommodation for 3 combined contacts, type of contact socket, fixing with 4-40 UNC thread and solder pins, for panel mounting frame VS-15-...



### Key Commercial Data

Packing unit	1 pc
Minimum order quantity	10 pc
Weight per Piece (excluding packing)	11.75 g
Custom tariff number	85366990
Country of origin	Germany

### Technical data

#### Mechanical characteristics

Number of positions	3
Insertion/withdrawal cycles	≥ 500
Connection method	Fitting to accept combined contact
Type of contact	Socket
Mounting type	Threads and solder pins

#### Ambient conditions

Ambient temperature (operation)	-55 °C ... 125 °C
---------------------------------	-------------------

#### Material data

Flammability rating according to UL 94	V0
Housing material	Steel, yellow chromated
Contact carrier material	PBTP
Contact surface material	Gold over nickel

#### Electrical characteristics

## D-SUB contact support - VS-15-BU-DSUB-3P-LH - 1655328

### Technical data

#### Electrical characteristics

Number of positions	3
---------------------	---

#### Standards and Regulations

Flammability rating according to UL 94	V0
--	----

### Classifications

#### eCl@ss

eCl@ss 4.0	27140816
eCl@ss 4.1	27260701
eCl@ss 5.0	27260701
eCl@ss 5.1	27260701
eCl@ss 6.0	27260705
eCl@ss 7.0	27440309
eCl@ss 8.0	27440302
eCl@ss 9.0	27440205

#### ETIM

ETIM 2.0	EC000438
ETIM 3.0	EC000438
ETIM 4.0	EC000438
ETIM 5.0	EC001132

#### UNSPSC

UNSPSC 6.01	30211923
UNSPSC 7.0901	39121522
UNSPSC 11	39121522
UNSPSC 12.01	39121522
UNSPSC 13.2	39121522

### Approvals

#### Approvals

---

Approvals

EAC / UL Recognized / EAC

---

# D-SUB contact support - VS-15-BU-DSUB-3P-LH - 1655328

## Approvals

Ex Approvals

---

Approvals submitted

## Approval details

EAC

UL Recognized 

EAC

## Drawings

Schematic diagram

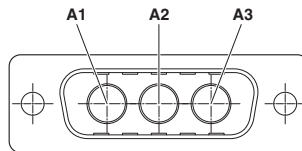

# D-SUB contact support - VS-15-BU-DSUB-3P-LH - 1655328

Dimensional drawing

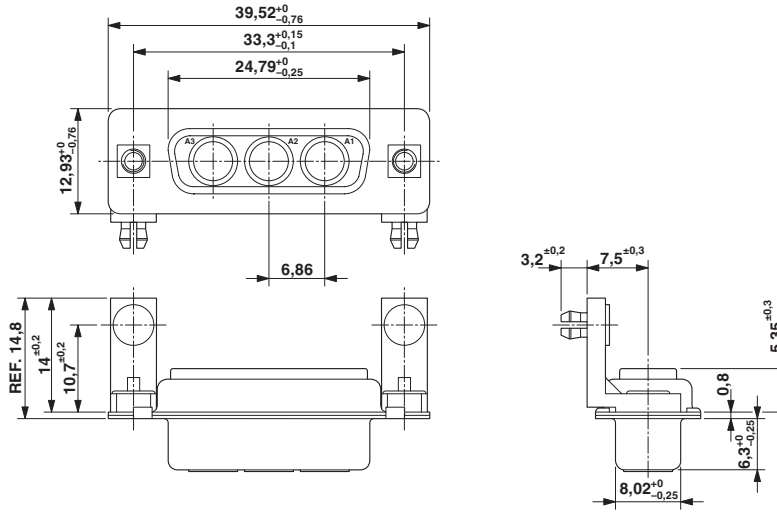

D-SUB contact carrier