

Device connector, front mounting - ST-17S1N8AAD00S - 1607652

Please be informed that the data shown in this PDF Document is generated from our Online Catalog. Please find the complete data in the user's documentation. Our General Terms of Use for Downloads are valid (<http://phoenixcontact.com/download>)



Device connector, front mounting, angled rotatable, SPEEDCON locking, M17, number of positions: 17, type of contact: Socket, Crimp connection, Axial O-ring, 4x Ø2,7, shielded: yes, flange dimensions: 21.6 mm x 21.6 mm



Key Commercial Data

Packing unit	16 pc
GTIN	
GTIN	4046356273602

Technical data

General

Note	Order information: Order crimp contacts Ø 0.6 mm separately
Type of locking	SPEEDCON locking
Direction of rotation of contact chamber numbering	Standard
Coding	N
Contact connection method	Crimp connection
Type of contacts	Socket
Number of positions	17
Contact diameter of power contacts	0.6 mm
Nominal current per power contact at 25°C	3.6 A
Pg housing screw connection	none
Mounting type	4x Ø2,7

Ambient conditions

Ambient temperature	-40 °C ... 125 °C
Degree of protection	IP67

Material

Housing material	Turned parts: copper zinc alloy (CuZn), die-cast parts: zinc (GD-Zn)
Insulator material	PA 6.6

Device connector, front mounting - ST-17S1N8AAD00S - 1607652

Technical data

Material

Gasket and O-ring material	FPM
----------------------------	-----

Specifications according to DIN EN 61984:2001

Installation height max.	3000 m
Nominal / operating voltage of power contacts	60 V
Rated surge voltage of power contacts	1.5 kV
Overvoltage category of power contacts	III
Degree of pollution of power contacts	3

Environmental Product Compliance

China RoHS	Environmentally Friendly Use Period = 50
	For details about hazardous substances go to tab "Downloads", Category "Manufacturer's declaration"

Drawings

Schematic diagram

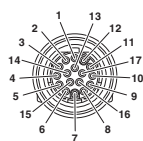

Connector pin assignment

Diagram

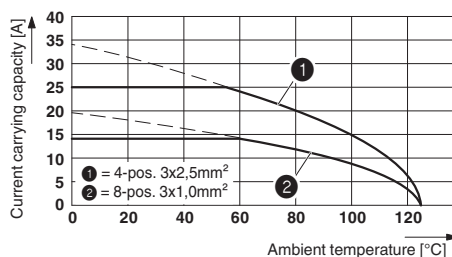

Diagram

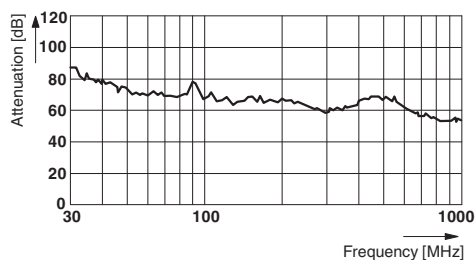

Dimensional drawing

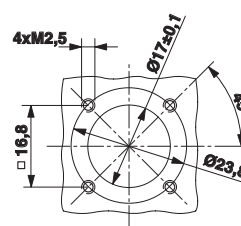

Device connector, front mounting - ST-17S1N8AAD00S - 1607652

Dimensional drawing

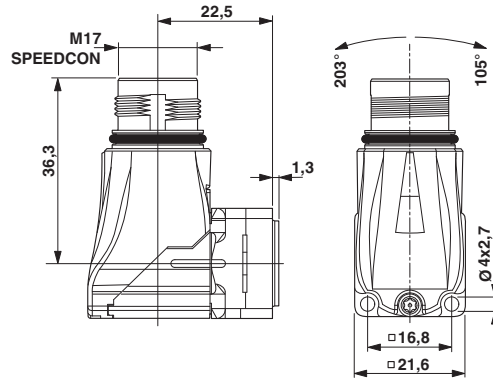

Approvals

Approvals

Approvals

UL Recognized / cUL Recognized / EAC / cULus Recognized

Ex Approvals

Approval details

UL Recognized		http://database.ul.com/cgi-bin/XYV/template/LISEXT/1FRAME/index.htm	FILE E 335019
Nominal voltage UN	60 V		
Nominal current IN	1 A		
mm ² /AWG/kcmil	26		

cUL Recognized		http://database.ul.com/cgi-bin/XYV/template/LISEXT/1FRAME/index.htm	FILE E 335019
Nominal voltage UN	60 V		
Nominal current IN	1 A		
mm ² /AWG/kcmil	26		

Device connector, front mounting - ST-17S1N8AAD00S - 1607652

Approvals

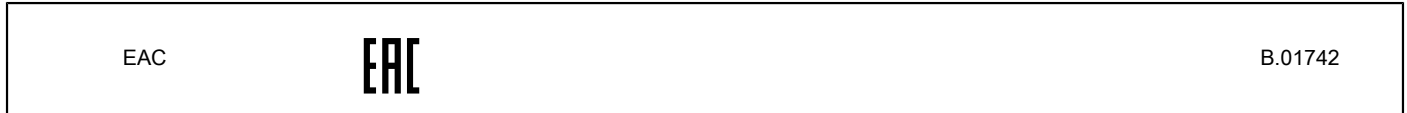

Phoenix Contact 2018 © - all rights reserved
<http://www.phoenixcontact.com>

PHOENIX CONTACT GmbH & Co. KG
Flachsmarktstr. 8
32825 Blomberg
Germany
Tel. +49 5235 300
Fax +49 5235 3 41200
<http://www.phoenixcontact.com>