

## Locking clip - SAC-M12-EXCLIP-F - 1558991

Please be informed that the data shown in this PDF Document is generated from our Online Catalog. Please find the complete data in the user's documentation. Our General Terms of Use for Downloads are valid (<http://phoenixcontact.com/download>)



Locking clip for the socket side of sensor/actuator cables with M12 connector and M12 connectors for assembly, for knurl diameter: 15 mm or for Allen key with a wrench size of 14 mm, prevents the disconnection of plug-in connections without tools

RoHS

### Key Commercial Data

Packing unit	1 pc
Minimum order quantity	10 pc
GTIN	 4 046356 299169
GTIN	4046356299169
Weight per Piece (excluding packing)	2.570 g
Custom tariff number	39269097
Country of origin	China

### Technical data

#### Ambient conditions

Ambient temperature (operation)	-40 °C ... 90 °C (Locking clip)
	-40 °C ... 65 °C (for installation)
Ambient temperature (storage/transport)	-40 °C ... 105 °C

#### Material

Flammability rating according to UL 94	V0
Material	TPE-U

#### Standards and Regulations

Flammability rating according to UL 94	V0
--	----

#### Environmental Product Compliance

# Locking clip - SAC-M12-EXCLIP-F - 1558991

## Technical data

### Environmental Product Compliance

China RoHS	Environmentally friendly use period: unlimited = EFUP-e
	No hazardous substances above threshold values

## Drawings

Dimensional drawing

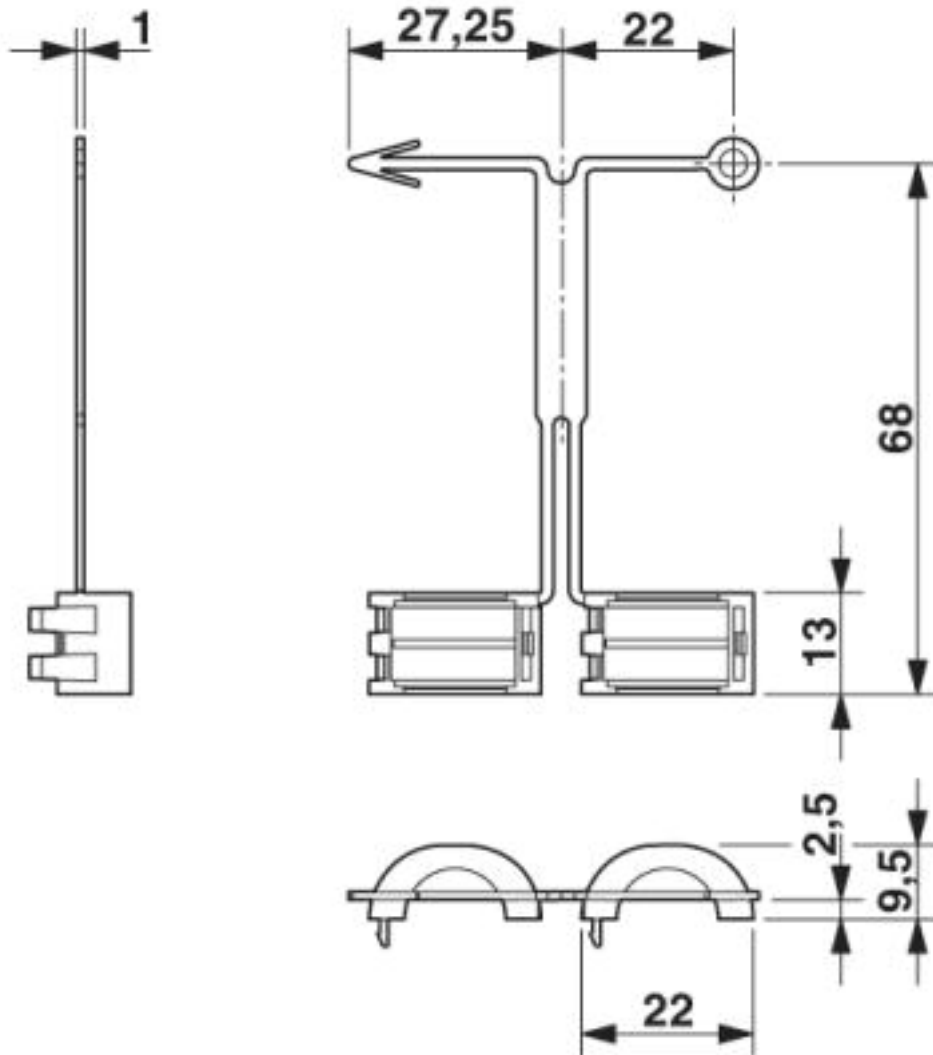

## Locking clip - SAC-M12-EXCLIP-F - 1558991

Dimensional drawing

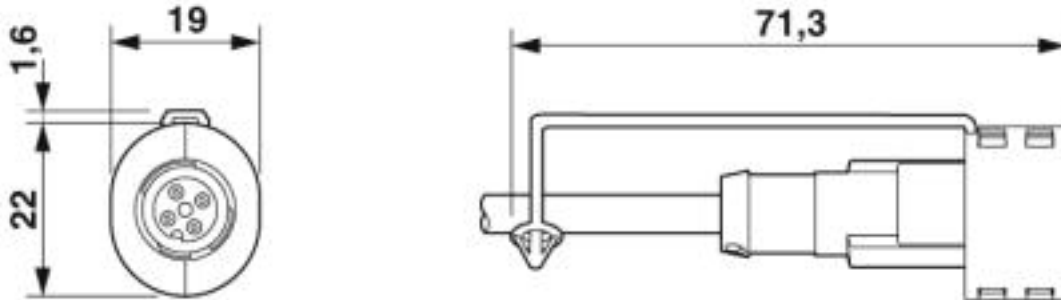

Locking clip mounted on straight M12 connector (not supplied as standard)

Dimensional drawing

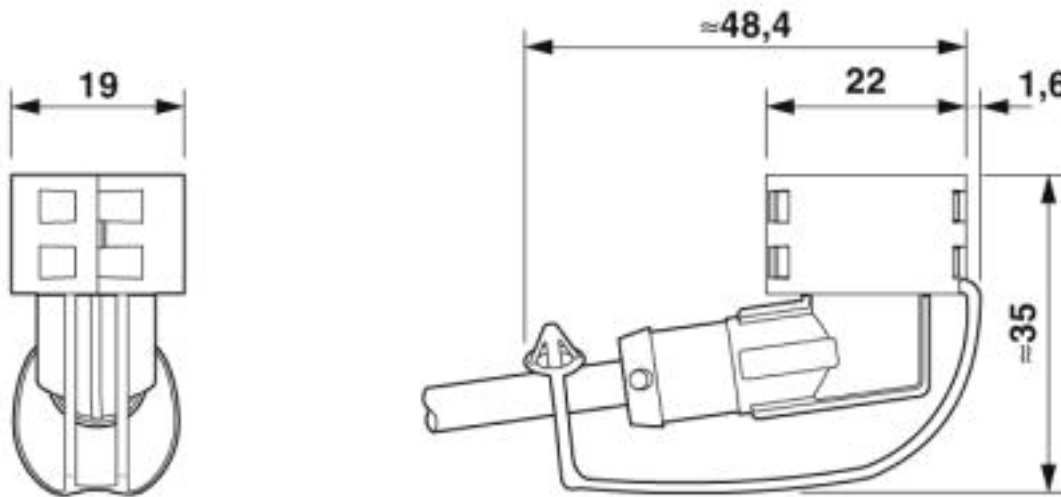

Locking clip mounted on angled M12 connector (not supplied as standard)

## Classifications

eCl@ss

eCl@ss 10.0.1	27440192
eCl@ss 4.0	23150100
eCl@ss 4.1	23150100
eCl@ss 5.0	23159000
eCl@ss 5.1	23159000
eCl@ss 6.0	23159000
eCl@ss 7.0	23159090
eCl@ss 8.0	23159090

# Locking clip - SAC-M12-EXCLIP-F - 1558991

## Classifications

eCl@ss

eCl@ss 9.0	27440192
------------	----------

## ETIM

ETIM 3.0	EC000464
ETIM 4.0	EC000464
ETIM 5.0	EC000464
ETIM 6.0	EC000464
ETIM 7.0	EC000464

## UNSPSC

UNSPSC 6.01	31251501
UNSPSC 7.0901	31251501
UNSPSC 11	31251501
UNSPSC 12.01	31251501
UNSPSC 13.2	31162906

## Accessories

### Accessories

#### Screwdriver tools

Screwdriver - SF-SL 0,8X4,0-100 - 1212551



Screwdriver, bladed (lasered), size: 0.8 x 4.0 x 100 mm, 2-component grip, with non-slip grip