

## Housing - HC-STA-B32-BWD-ELC-AL - 1424845

Please be informed that the data shown in this PDF Document is generated from our Online Catalog. Please find the complete data in the user's documentation. Our General Terms of Use for Downloads are valid (<http://phoenixcontact.com/download>)



Panel mounting base B32, with double locking latch, material: Die-cast aluminum, salt water resistant, height: 32.4 mm, cable gland: none, support sleeve: no, Standard, with flat gasket

### Your advantages

- good shielding in the event of electromagnetic interference



### Key Commercial Data

Packing unit	1 pc
GTIN	 4 055626 382500
GTIN	4055626382500
Weight per Piece (excluding packing)	220.000 g
Custom tariff number	85389099
Country of origin	China

### Technical data

#### Dimensions

Height	32.4 mm
Width	91.7 mm
Length	123 mm
Length of the assembly cutout	86 mm
Width of the assembly cutout	71 mm

#### Ambient conditions

Degree of protection (IP)	IP66
---------------------------	------

# Housing - HC-STA-B32-BWD-ELC-AL - 1424845

## Technical data

### Ambient conditions

	IP67
Ambient temperature (operation)	-40 °C ... 125 °C

### General

Size	B32
Housing type	Panel mounting base
Color	gray aluminum
Locking type	with double locking latch
Torque	1.5 Nm ... 2 Nm (Mounting screw)
Screw connection	none
Housing material	Die-cast aluminum, salt water resistant
Housing surface material	uncoated
Seal material	NBR, conductive
Material lock	Polyamide

### Environmental Product Compliance

China RoHS	Environmentally Friendly Use Period = 50
	For details about hazardous substances go to tab "Downloads", Category "Manufacturer's declaration"

## Drawings

Dimensional drawing

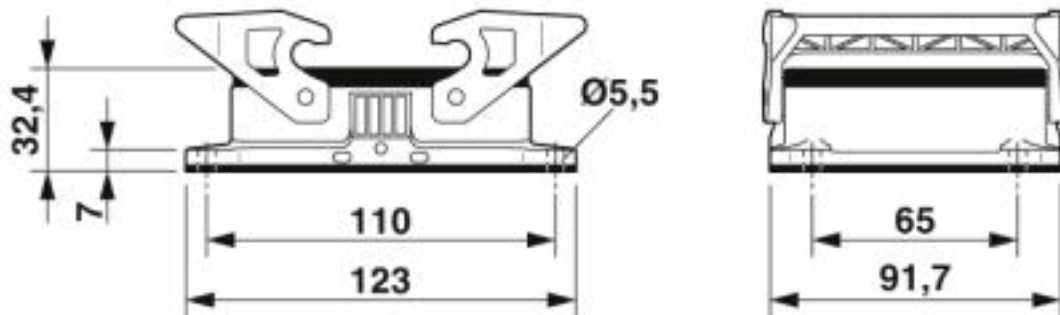

Dimensional drawing

# Housing - HC-STA-B32-BWD-ELC-AL - 1424845

Dimensional drawing

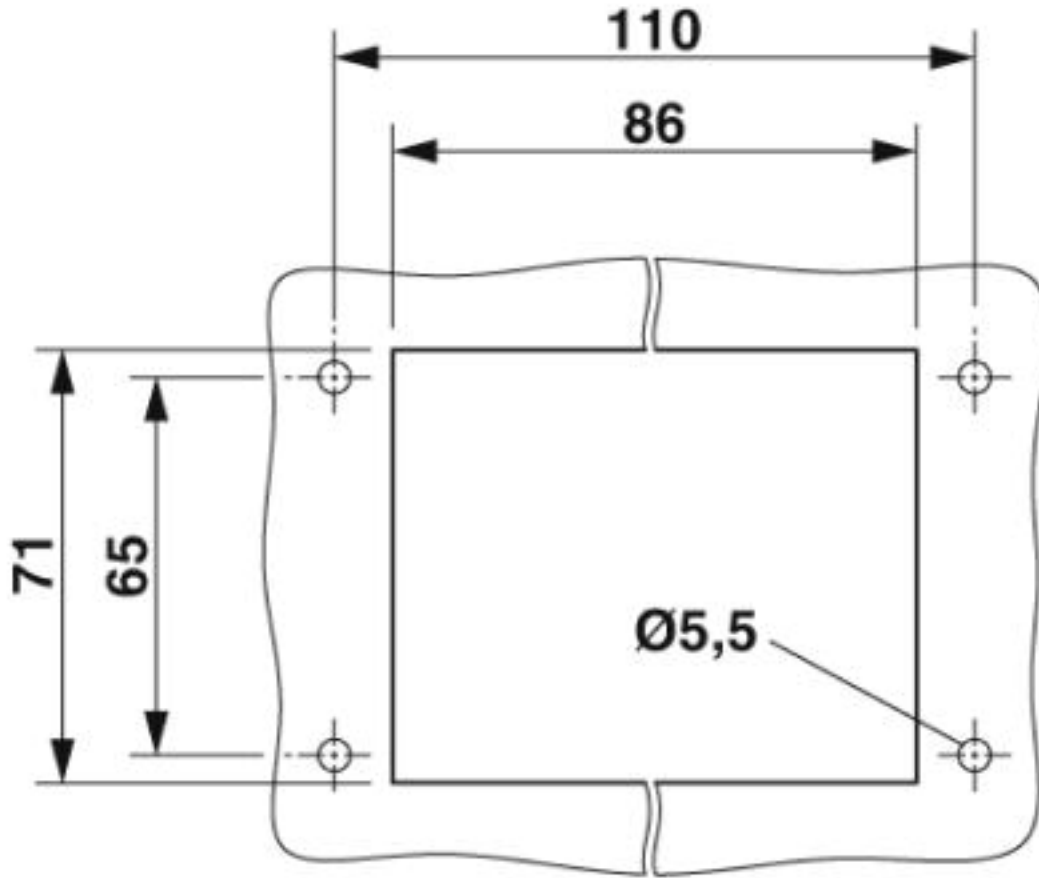

Mounting cutout

## Classifications

eCl@ss

eCl@ss 5.1	27261200
eCl@ss 6.0	27261200
eCl@ss 7.0	27440202
eCl@ss 8.0	27440202
eCl@ss 9.0	27440202

ETIM

ETIM 5.0	EC000437
ETIM 6.0	EC000437
ETIM 7.0	EC000437

# Housing - HC-STA-B32-BWD-ELC-AL - 1424845

## Approvals

Approvals

---

Approvals

EAC / DNV GL

---

Ex Approvals

---

## Approval details

EAC			RU C- DE.AI30.B.01102
-----	---	--	--------------------------

DNV GL		<a href="https://approvalfinder.dnvgl.com/">https://approvalfinder.dnvgl.com/</a>	TAE000037S
--------	--	---	------------

## Accessories

Accessories

Protective cover

Protective covers - HC-STA-B32-BCSFD-PL-BK - 1424850



Protective cover B32, for double locking latch, protective cover material: PA, height: 24.8 mm, seal: no, Standard, With lanyard