

Membrane screw connection - MG-INC-M25-M67L-PTES-LG - 1415188

Please be informed that the data shown in this PDF Document is generated from our Online Catalog. Please find the complete data in the user's documentation. Our General Terms of Use for Downloads are valid (<http://phoenixcontact.com/download>)



Membrane screw connection, cable gland material: Polypropylene, external cable diameter 9 mm ... 17 mm, shielding: no, connecting thread: M25, color: light gray



Key Commercial Data

Packing unit	1 pc
Minimum order quantity	20 pc
GTIN	 4 055626 038025
GTIN	4055626038025
Weight per Piece (excluding packing)	6.000 g
Custom tariff number	39269097
Country of origin	Germany

Technical data

Dimensions

Length	15 mm
Length without connecting thread	7 mm
Connecting thread diameter	25 mm
Hexagon angular dimension	40 mm
Length of the connecting thread	8 mm
Feed-through hole diameter	25 mm ... 25.7 mm
External cable diameter	9 mm ... 17 mm

Ambient conditions

Degree of protection (IP)	IP66
	IP67

Membrane screw connection - MG-INC-M25-M67L-PTES-LG - 1415188

Technical data

Ambient conditions

Ambient temperature (operation)	-40 °C ... 65 °C
---------------------------------	------------------

General

Cable gland material	Polypropylene
Seal material	TPE
Shielded	no
Thread type on connection side	M25
Color	light gray
Assembly instructions	for 0.8 mm ... 3.5 mm wall thickness, 25 mm ... 25.7 mm bore hole
Manufacturer	WISKA
Manufacturer Designation	CLIXX 25

Environmental Product Compliance

China RoHS	Environmentally friendly use period: unlimited = EFUP-e
	No hazardous substances above threshold values

Drawings

Membrane screw connection - MG-INC-M25-M67L-PTES-LG - 1415188

Dimensional drawing

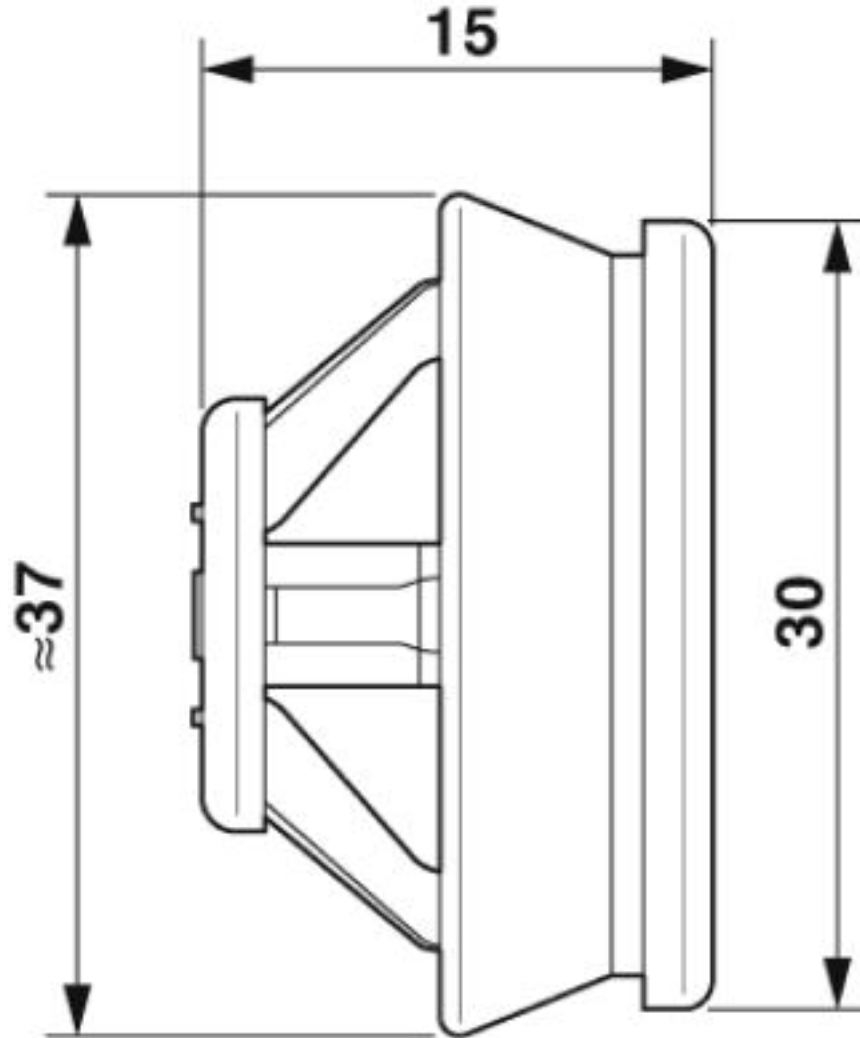

Classifications

eCl@ss

eCl@ss 10.0.1	27144433
eCl@ss 4.0	27141200
eCl@ss 4.1	27141200
eCl@ss 5.0	27149100
eCl@ss 5.1	27149100
eCl@ss 6.0	27379200
eCl@ss 7.0	27379216

Membrane screw connection - MG-INC-M25-M67L-PTES-LG - 1415188

Classifications

eCl@ss

eCl@ss 8.0	27379216
eCl@ss 9.0	27144433

ETIM

ETIM 5.0	EC002024
ETIM 6.0	EC000451
ETIM 7.0	EC000451

UNSPSC

UNSPSC 13.2	32151802
UNSPSC 18.0	39121311
UNSPSC 19.0	39121311
UNSPSC 20.0	39121311
UNSPSC 21.0	39121311