

Housing - HC-EVO-D15-SLWS-2SSM25-PLR-BK - 1411341

Please be informed that the data shown in this PDF Document is generated from our Online Catalog. Please find the complete data in the user's documentation. Our General Terms of Use for Downloads are valid (<http://phoenixcontact.com/download>)



Box mounting bases D15, with single locking latch, material: PA, cable outlets: 2, lateral, height: 52 mm, cable gland: none, support sleeve: no, 2x M25, Standard

Your advantages

- ✓ Flexible cable outlet direction, lateral or straight
- ✓ Lower costs than metal version
- ✓ Labeling option using 9 x 20 mm marking label
- ✓ Low weight
- ✓ Lower risk of condensation
- ✓ Both contact insert PE sheets are connected by means of a metal frame integrated in the sleeve housing
- ✓ Metal inlays ensure leading PE contact with angled plugs
- ✓ Completely corrosion-resistant
- ✓ Halogen-free plastic



Key Commercial Data

Packing unit	1 pc
GTIN	
GTIN	4046356929127
Weight per Piece (excluding packing)	80.000 g
Custom tariff number	85389099
Country of origin	Poland

Technical data

Dimensions

Height	52 mm
--------	-------

Housing - HC-EVO-D15-SLWS-2SSM25-PLR-BK - 1411341

Technical data

Dimensions

Width	51 mm
Length	80 mm

Ambient conditions

Degree of protection (IP)	IP66
Degree of protection (NEMA)	12 (UL 50e)
Ambient temperature (operation)	-40 °C ... 125 °C

General

Note	For contact inserts HC-D15, A10
Size	D15
Housing type	Box mounting bases
Color	black
Locking type	with single locking latch
No. of cable outlets	2
Cable outlet	lateral
Screw connection	none
Type of the screw connection	2x M25
Housing material	PA
Material lock	PA
Flammability rating according to UL 94	V0
Connection	One of the two openings for the screw connections is sealed but can be broken open using a screwdriver.

Standards and Regulations

Flammability rating according to UL 94	V0
--	----

Environmental Product Compliance

China RoHS	Environmentally friendly use period: unlimited = EFUP-e
	No hazardous substances above threshold values

Drawings

Housing - HC-EVO-D15-SLWS-2SSM25-PLR-BK - 1411341

Dimensional drawing

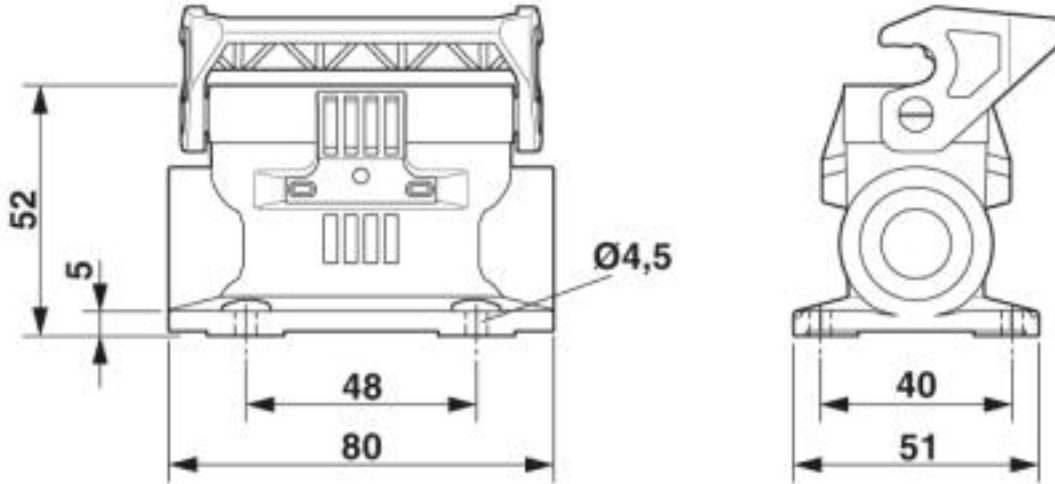

Dimensional drawing

Classifications

eCl@ss

eCl@ss 10.0.1	27440202
eCl@ss 5.1	27261200
eCl@ss 6.0	27261200
eCl@ss 7.0	27440202
eCl@ss 8.0	27440202
eCl@ss 9.0	27440202

ETIM

ETIM 4.0	EC000437
ETIM 5.0	EC000437
ETIM 6.0	EC000437
ETIM 7.0	EC000437

UNSPSC

UNSPSC 13.2	31261501
-------------	----------

Approvals

Approvals

Housing - HC-EVO-D15-SLWS-2SSM25-PLR-BK - 1411341

Approvals

Approvals

EAC / DNV GL

Ex Approvals

Approval details

EAC		RU C- DE.AI30.B.01102
-----	--	--------------------------

DNV GL		https://approvalfinder.dnvgl.com/	TAE000037S
--------	--	---	------------

Accessories

Accessories

Full screw connection

Cable gland - HC-K-KV-M25(8-17)BK - 1411258



Plastic screw connection, IP68, up to 5 bar, thread length: 8 mm, cable diameter: 8 - 17 mm, WAF 29, screw connection: M25

Module carrier frame

Module carrier frame - HC-M-D15-MF-HB - 1062122

Module carrier frame, size: D15, 0.14 mm² ... 2.5 mm², application: Module carrier frame, for size D15 housings



Plug for cable screw gland

Housing - HC-EVO-D15-SLWS-2SSM25-PLR-BK - 1411341

Accessories

Filler plugs - HC-K-BS-M25 BK - 1411245



Filler plug, plastic, size: M25

Protective cover

Protective covers - HC-D15-BCSFS-PRBK - 1414641



Protective cover D15, for single locking latch, protective cover material: PA, height: 20.5 mm, seal: yes

Reducing adapter

Reducing adapter - REDUC-K-KV-M25/M20 BK - 1411232



Reducing adapter, material: Polyamide fiberglass reinforced, connecting thread: M25 x 1.5, color: black, with flat gasket