

Housing - HC-EVO-D15-HHFS-PL-BK - 1411340

Please be informed that the data shown in this PDF Document is generated from our Online Catalog. Please find the complete data in the user's documentation. Our General Terms of Use for Downloads are valid (<http://phoenixcontact.com/download>)



Sleeve housing D15, for single locking latch, material: PA, cable outlets: 1, straight/lateral, height: 65.5 mm, cable gland: none, support sleeve: no, Standard

Your advantages

- ✓ Flexible cable outlet direction, lateral or straight
- ✓ Lower costs than metal version
- ✓ Labeling option using 9 x 20 mm marking label
- ✓ Low weight
- ✓ Lower risk of condensation
- ✓ Both contact insert PE sheets are connected by means of a metal frame integrated in the sleeve housing
- ✓ Metal inlays ensure leading PE contact with angled plugs
- ✓ Completely corrosion-resistant
- ✓ Halogen-free plastic



Key Commercial Data

Packing unit	1 pc
GTIN	 4 046356 929110
GTIN	4046356929110
Weight per Piece (excluding packing)	60.000 g
Custom tariff number	85389099
Country of origin	Poland

Technical data

Dimensions

Height	65.5 mm
--------	---------

Housing - HC-EVO-D15-HHFS-PL-BK - 1411340

Technical data

Dimensions

Width	30 mm
Length	63.5 mm

Ambient conditions

Degree of protection (IP)	IP66
Degree of protection (NEMA)	12 (UL 50e)
Ambient temperature (operation)	-40 °C ... 125 °C

General

Note	For contact inserts HC-D15, A10
Size	D15
Housing type	Sleeve housing
Color	black
Locking type	for single locking latch
No. of cable outlets	1
Cable outlet	straight
	lateral
Screw connection	none
Housing material	PA
Flammability rating according to UL 94	V0
Connection	The sleeve base housing must be supplemented with the EVO screw connection. The EVO screw connection is available in 4 sizes. It enables the creation of a straight or lateral cable outlet. The EVO screw connection is mounted by hand or with the aid of a pipe wrench, for example.

Standards and Regulations

Flammability rating according to UL 94	V0
--	----

Environmental Product Compliance

China RoHS	Environmentally friendly use period: unlimited = EFUP-e
	No hazardous substances above threshold values

Drawings

Housing - HC-EVO-D15-HHFS-PL-BK - 1411340

Dimensional drawing

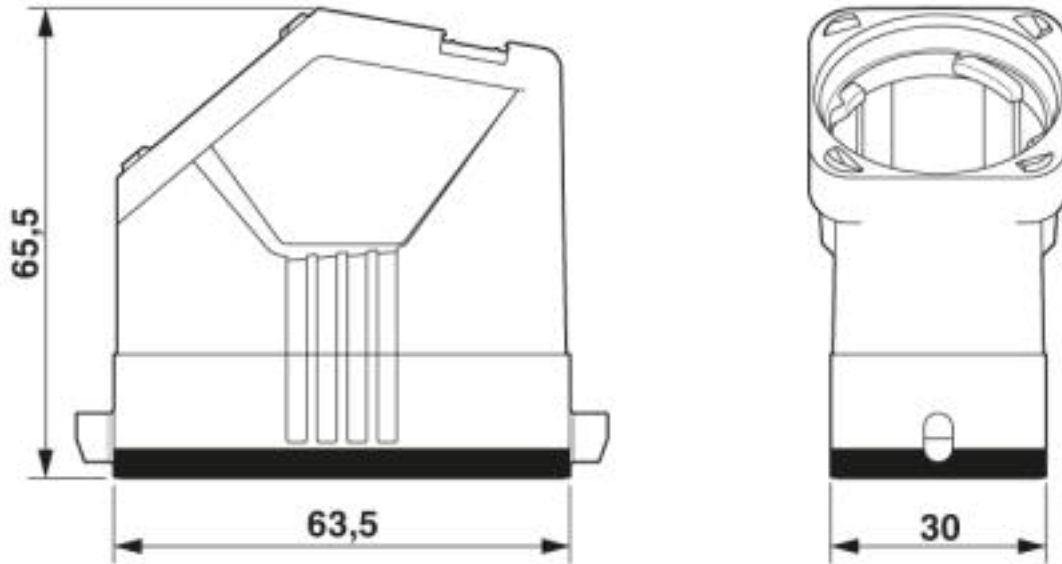

Dimensional drawing

Classifications

eCl@ss

eCl@ss 10.0.1	27440202
eCl@ss 5.1	27261200
eCl@ss 6.0	27261200
eCl@ss 7.0	27440202
eCl@ss 8.0	27440202
eCl@ss 9.0	27440202

ETIM

ETIM 4.0	EC000437
ETIM 5.0	EC000437
ETIM 6.0	EC000437
ETIM 7.0	EC000437

UNSPSC

UNSPSC 13.2	31261501
-------------	----------

Approvals

Approvals

Housing - HC-EVO-D15-HHFS-PL-BK - 1411340

Approvals

Approvals

EAC / DNV GL

Ex Approvals

Approval details

EAC		RU C- DE.AI30.B.01102
-----	--	--------------------------

DNV GL		https://approvalfinder.dnvgl.com/	TAE000037S
--------	--	---	------------

Accessories

Accessories

Cable gland with bayonet locking

Cable gland - HC-D-G-M20-PLRBK - 1411350



EVO plastic cable gland with bayonet locking, for housing series D, size M20, cable diameter: 7 - 13 mm.

Cable gland - HC-D-G-M25-PLRBK - 1411351



EVO plastic cable gland with bayonet locking, for housing series D, size M25, cable diameter: 9 ... 17 mm.

Module carrier frame

Housing - HC-EVO-D15-HHFS-PL-BK - 1411340

Accessories

Module carrier frame - HC-M-D15-MF-HB - 1062122

Module carrier frame, size: D15, 0.14 mm² ... 2.5 mm², application: Module carrier frame, for size D15 housings

