

Connector - QPD P 4PE2,5 6-11 BK - 1403784

Please be informed that the data shown in this PDF Document is generated from our Online Catalog. Please find the complete data in the user's documentation. Our General Terms of Use for Downloads are valid (<http://phoenixcontact.com/download>)



QUICKON connector, black, 4+PE-pos., 1.0 mm² ... 2.5 mm²/690 V/20 A, with QUICKON nut, for cables with 6 mm ... 11 mm diameter.

Your advantages

- ✓ Innovative and time saving - QUICKON fast connection for time saving of up to 80 % for on-site connection
- ✓ Convenient: quick and easy assembly without special tools
- ✓ Robust throughout: housing with IP68/IP69K and IK07 protection for a wide range of applications
- ✓ Safer connection thanks to polarization against mismatching and touch-proof protection according to DIN EN 0105
- ✓ Easy maintenance - the connectors enable fast device replacement and simplify startup thanks to pre-assembled cables

Key Commercial Data

Packing unit	1 pc
GTIN	 4 046356 667159
GTIN	4046356667159
Weight per Piece (excluding packing)	78.400 g
Custom tariff number	85366990
Country of origin	Poland

Technical data

General

Type	QPD 5x2,5
Color	black
Locking type	Screw locking
Connection method	QUICKON connection
	IDC connection

Connector - QPD P 4PE2,5 6-11 BK - 1403784

Technical data

General

Number of positions	5
Note number of positions	4+PE
Wrench size, union nut	27 mm
Tightening torque, union nut	10 Nm
Number of connections	5
Conductor cross section flexible min.	1 mm ²
Conductor cross section flexible max.	2.5 mm ²
Conductor cross section solid min.	1 mm ²
Conductor cross section solid max.	2.5 mm ²
Conductor cross section AWG min.	16
Conductor cross section AWG max.	14

Cabel

Structure of individual litz in acc. with VDE 0295 / smallest wire diameter	VDE 0295 class 1 to 6/min. 0.15 mm
Wire insulation material	PVC/PE/TPE/rubber
Wire diameter including insulation	2 mm ... 3.8 mm
External cable diameter	6 mm ... 11 mm

Ambient conditions

Degree of protection	IP66
	IP68 (2 m / 24 h)
	IP69K
Ambient temperature (operation)	-40 °C ... 100 °C
Ambient temperature (storage/transport)	-40 °C ... 80 °C
Temperature when conductor connected	-5 °C ... 50 °C

Electrical characteristics

Nominal current I _N	20 A
Rated current	20 A
Rated voltage (III/3)	690 V
Rated voltage (III/2)	1000 V
Rated voltage (II/2)	1000 V
Rated surge voltage (III/3)	6 kV
Rated surge voltage (III/2)	8 kV
Rated surge voltage (II/2)	8 kV

Mechanical characteristics

QUICKON connectability	max. 10
Insertion/withdrawal cycles	50

Connector - QPD P 4PE2,5 6-11 BK - 1403784

Technical data

Mechanical characteristics

Category of shock impact	IK07
--------------------------	------

Material data

Contact material	Cu
Contact surface material	silver-plated
Contact carrier material	PA
Insulating material	PA
Flammability rating according to UL 94	V0
Overvoltage category	III
Degree of pollution	3

Standards and Regulations

Flammability rating according to UL 94	V0
--	----

Environmental Product Compliance

China RoHS	Environmentally friendly use period: unlimited = EFUP-e
	No hazardous substances above threshold values

Drawings

Diagram

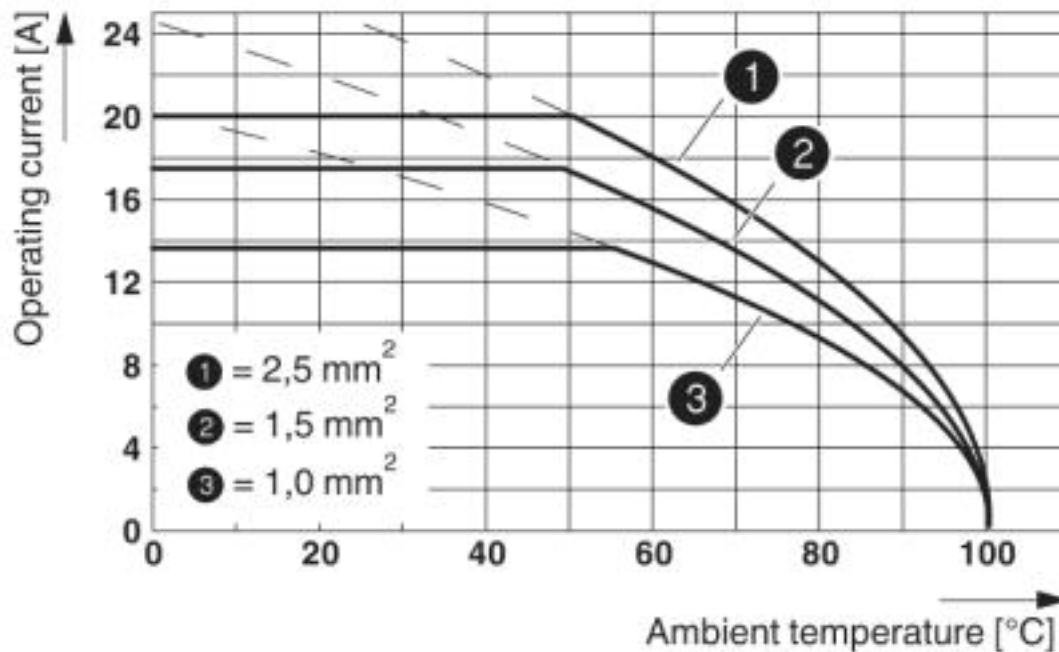

Connector - QPD P 4PE2,5 6-11 BK - 1403784

Dimensional drawing

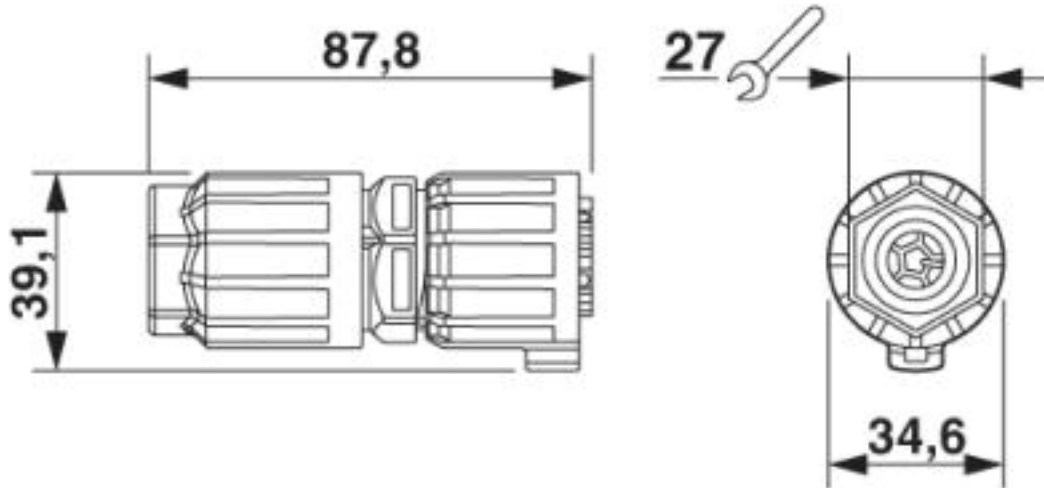

Dimensional drawing: connector, 2.5 mm²

Classifications

eCl@ss

eCl@ss 4.0	27140800
eCl@ss 4.1	27140800
eCl@ss 5.0	27143400
eCl@ss 5.1	27143400
eCl@ss 6.0	27143400
eCl@ss 7.0	27440605
eCl@ss 8.0	27440605
eCl@ss 9.0	27440605

ETIM

ETIM 3.0	EC001121
ETIM 4.0	EC000516
ETIM 5.0	EC002560
ETIM 6.0	EC002560
ETIM 7.0	EC002560

UNSPSC

UNSPSC 6.01	30211923
UNSPSC 7.0901	39121522
UNSPSC 11	39121522

Connector - QPD P 4PE2,5 6-11 BK - 1403784

Classifications

UNSPSC

UNSPSC 12.01	39121522
UNSPSC 13.2	39121522

Approvals

Approvals

Approvals

IECEE CB Scheme / VDE Zeichengenehmigung / EAC / DNV GL

Ex Approvals

Approval details

IECEE CB Scheme		http://www.iecee.org/	DE1-61559
-----------------	---	---	-----------

VDE Zeichengenehmigung		http://www2.vde.com/de/Institut/Online-Service/VDE-gepruefteProdukte/Seiten/Online-Suche.aspx	40029149
Nominal voltage UN	690 V		
Nominal current IN	20 A		
mm ² /AWG/kcmil	1-2.5		

EAC			RU C- DE.AI30.B.01102
-----	---	--	--------------------------

DNV GL		https://approvalfinder.dnvgl.com/	TAE00003J5
--------	---	---	------------

Accessories

Accessories

Connector - QPD P 4PE2,5 6-11 BK - 1403784

Accessories

Coding element

Coding profile - CP-QPD 5X2,5 - 1404530



Coding profile, red, for insertion into the 5-pos. QUICKON dome and connector, can be positioned in 72° increments.

Protective cap

Protective cap - QPD QSK 5X2,5 - 1404528



Protective cap, transparent plastic, for 5x 2.5 mm² QPD QUICKON connection, IP50.

Protective cap - QPD PSK 5X2,5 - 1404529



Protective cap, transparent plastic, for 5 x 2.5 mm² QPD connector, IP50.

Socket spanner

Socket wrench - QSS 27 - 1670646



Allen wrench, for loosening and fastening the QUICKON union nut, WAF 27 mm
