

Sensor/actuator cable - SAC-3P-M5MS/0,2-PUR/M5FS - 1402494

Please be informed that the data shown in this PDF Document is generated from our Online Catalog. Please find the complete data in the user's documentation. Our General Terms of Use for Downloads are valid (<http://phoenixcontact.com/download>)



Sensor/actuator cable, 3-position, PUR, black RAL 9005, Plug straight M5, coding: A, on Socket straight M5, coding: A, cable length: 0.2 m

RoHS

Key Commercial Data

Packing unit	1 pc
Minimum order quantity	50 pc
GTIN	 4 046356 620321
GTIN	4046356620321
Weight per Piece (excluding packing)	2.000 g
Custom tariff number	85444290
Country of origin	Germany

Technical data

Dimensions

Length of cable	0.2 m
-----------------	-------

Ambient conditions

Ambient temperature (operation)	-25 °C ... 80 °C (Plug / socket)
Degree of protection	IP65
	IP67

General

Rated current at 40°C	1 A
Rated voltage	48 V AC
	60 V DC

Sensor/actuator cable - SAC-3P-M5MS/0,2-PUR/M5FS - 1402494

Technical data

General

Number of positions	3
Insulation resistance	≥ 10 GΩ
Coding	A - standard
Status display	No
Overvoltage category	II
Degree of pollution	3
Insertion/withdrawal cycles	≥ 100

Material

Contact material	CuZn
Contact surface material	Au
Contact carrier material	PUR
Material of grip body	PUR
Material, knurls	Nickel-plated brass

Cable

Cable type	PUR/PVC black
Conductor cross section	3x 0.14 mm ² (Signal line)
AWG signal line	26
Conductor structure signal line	18x 0.10 mm
Core diameter including insulation	1.1 mm
Wire colors	brown, blue, black
Overall twist	3 wires, twisted
External sheath, color	black RAL 9005
External cable diameter D	3 mm ±0.2 mm
Smallest bending radius, fixed installation	8 mm
Smallest bending radius, movable installation	15 mm
Cable weight	12.9 kg/km
Outer sheath, material	PUR
Material conductor insulation	PVC
Conductor material	Bare Cu litz wires
Insulation resistance	100 MΩ*km
Conductor resistance	148 Ω/km
Nominal voltage, cable	250 V
Test voltage, cable	800 V _{rms}
Ambient temperature (operation)	-15 °C ... 80 °C (cable, fixed installation) -5 °C ... 80 °C (cable, flexible installation)

Environmental Product Compliance

Sensor/actuator cable - SAC-3P-M5MS/0,2-PUR/M5FS - 1402494

Technical data

Environmental Product Compliance

China RoHS	Environmentally Friendly Use Period = 50 years
	For details about hazardous substances go to tab "Downloads", Category "Manufacturer's declaration"

Drawings

Dimensional drawing

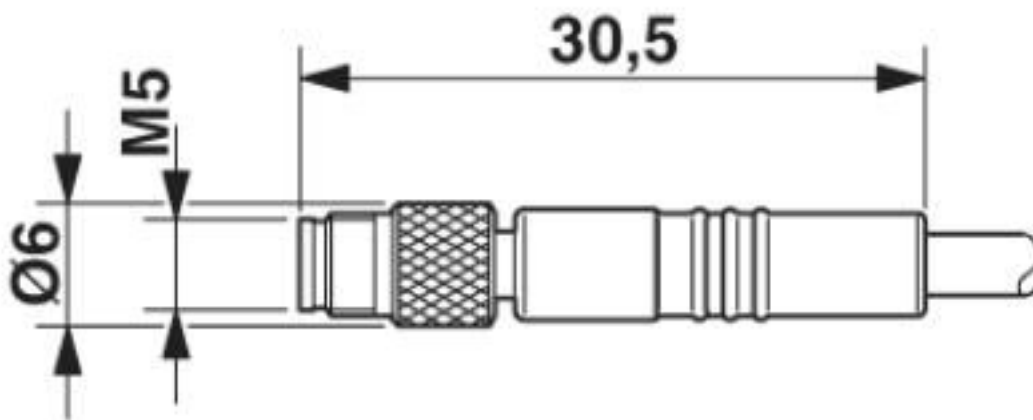

Plug M5 x 0.5, straight

Dimensional drawing

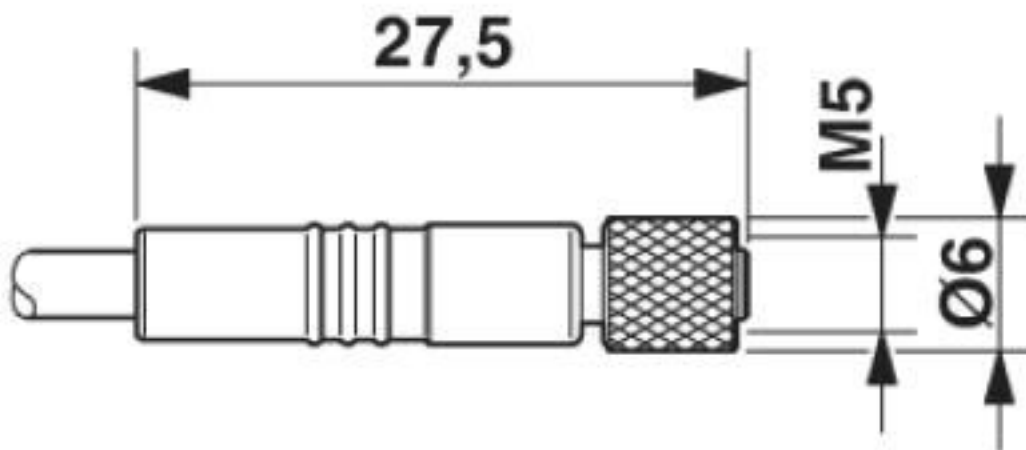

Socket M5 x 0.5, straight

Sensor/actuator cable - SAC-3P-M5MS/0,2-PUR/M5FS - 1402494

Circuit diagram

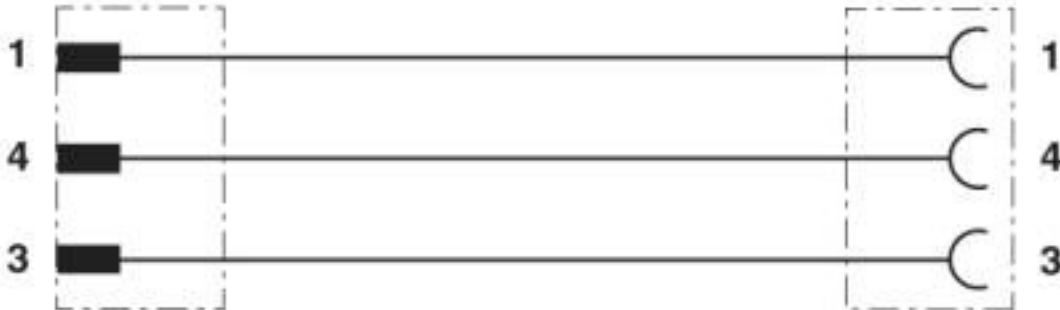

Contact assignment of the M5 male/female connectors

Sensor/actuator cable - SAC-3P-M5MS/0,2-PUR/M5FS - 1402494

Schematic diagram

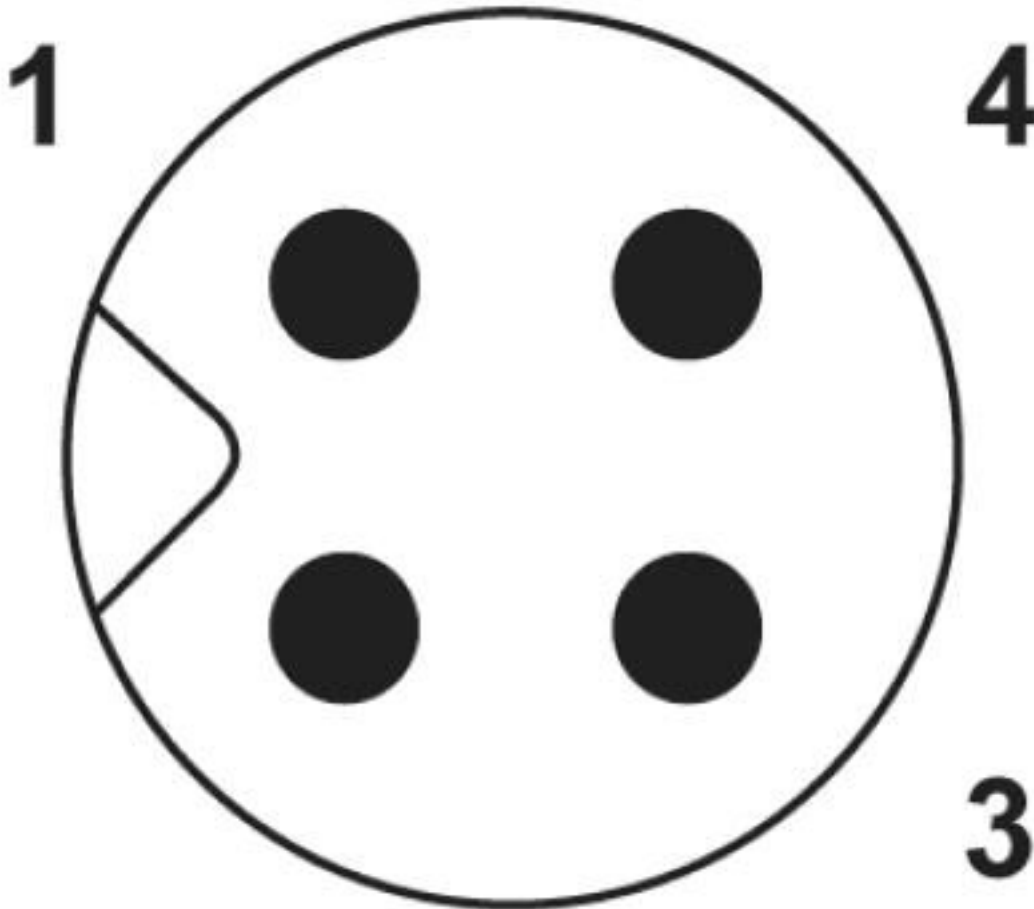

Plug M5, 3-pos.

Sensor/actuator cable - SAC-3P-M5MS/0,2-PUR/M5FS - 1402494

Schematic diagram

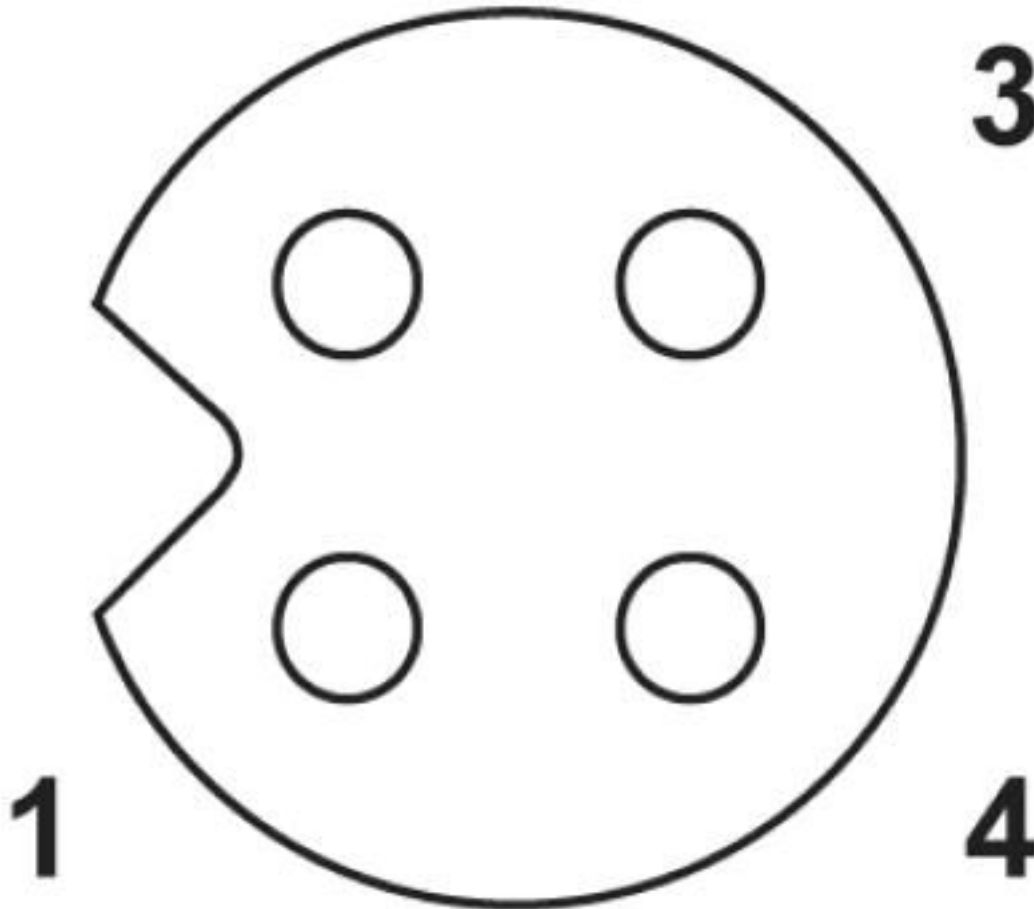

Socket M5, 3-pos.

Sensor/actuator cable - SAC-3P-M5MS/0,2-PUR/M5FS - 1402494

Cable cross section

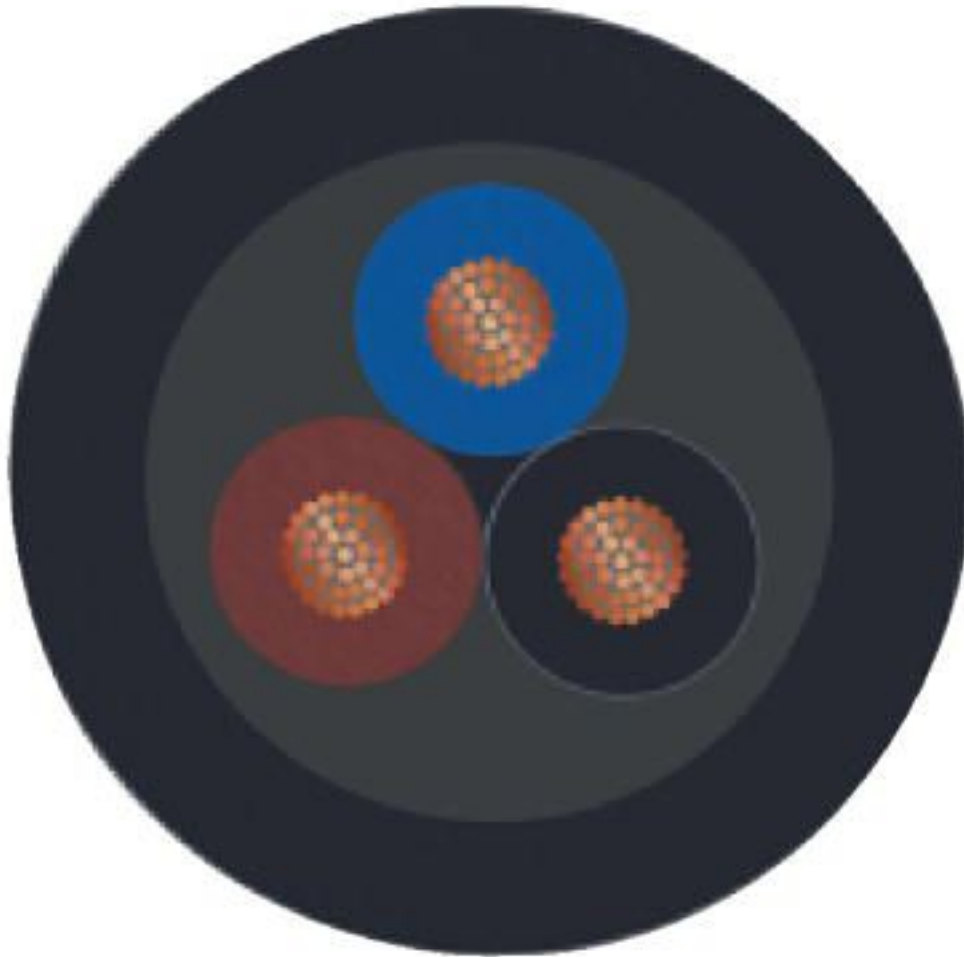

PUR/PVC black [350]

Classifications

eCl@ss

eCl@ss 4.0	27060300
eCl@ss 4.1	27060300
eCl@ss 5.0	27061800
eCl@ss 5.1	27061800
eCl@ss 6.0	27279200
eCl@ss 7.0	27279218
eCl@ss 8.0	27279218

Sensor/actuator cable - SAC-3P-M5MS/0,2-PUR/M5FS - 1402494

Classifications

eCl@ss

eCl@ss 9.0	27060311
------------	----------

ETIM

ETIM 4.0	EC001855
ETIM 5.0	EC001855
ETIM 6.0	EC001855
ETIM 7.0	EC001855

UNSPSC

UNSPSC 6.01	31251501
UNSPSC 7.0901	31251501
UNSPSC 11	31251501
UNSPSC 12.01	31251501
UNSPSC 13.2	31251501
UNSPSC 19.0	31251501

Accessories

Accessories

Conductor marking

Insert label - PABA WH/23 - 1013779



Insert label, Strip, white, unlabeled, can be labeled with: CMS-P1-PLOTTER, mounting type: thread on, cable diameter range: 1.5 ... 35 mm, lettering field size: 23 x 4 mm, Number of individual labels: 20

Insert label - PABA YE/23 - 1013782



Insert label, Strip, yellow, unlabeled, can be labeled with: CMS-P1-PLOTTER, mounting type: thread on, cable diameter range: 1.5 ... 35 mm, lettering field size: 23 x 4 mm, Number of individual labels: 20

Marker pen

Sensor/actuator cable - SAC-3P-M5MS/0,2-PUR/M5FS - 1402494

Accessories

Marker pen - B-STIFT - 1051993



Marker pen, for manual labeling of unprinted Zack strips, smear-proof and waterproof, line thickness 0.5 mm