

ebm-papst Mulfingen GmbH & Co. KG

Bachmühle 2 · D-74673 Mulfingen

Phone +49 7938 81-0

Fax +49 7938 81-110

info1@de.ebmpapst.com

www.ebmpapst.com

Limited partnership · Headquarters Mulfingen

County court Stuttgart · HRA 590344

General partner Elektrobau Mulfingen GmbH · Headquarters Mulfingen

County court Stuttgart · HRB 590142

Nominal data

Type	W2G107-AD03-47	
Motor	M2G045-BA	
Nominal voltage	VDC	24
Nominal voltage range	VDC	18 .. 30
Type of data definition		fa
Speed	min ⁻¹	2800
Power input	W	3.5
Min. ambient temperature	°C	-25
Max. ambient temperature	°C	72

ml = Max. load · me = Max. efficiency · fa = Running at free air · cs = Customer specs · cu = Customer unit
Subject to alterations



Technical features

Mass	0.5 kg
Size	107 mm
Material of blades	Sheet steel, coated in black
Material of wall ring	Die-cast aluminium, coated in black
Number of blades	5
Direction of air flow	"V"
Direction of rotation	Counter-clockwise, seen on rotor
Type of protection	IP 22
Max. permissible ambient motor temp. (transp./ storage)	+ 80 °C
Min. permissible ambient motor temp. (transp./storage)	- 40 °C
Mounting position	Any
Condensate discharge holes	None
Operation mode	S1
Motor bearing	Ball bearing
Technical features	- Tach output
Motor protection	Reverse polarity and locked-rotor protection
Product conforming to standard	EN 60335-1
Approval	CSA C22.2 Nr.113; EAC; UL 507

Product drawing

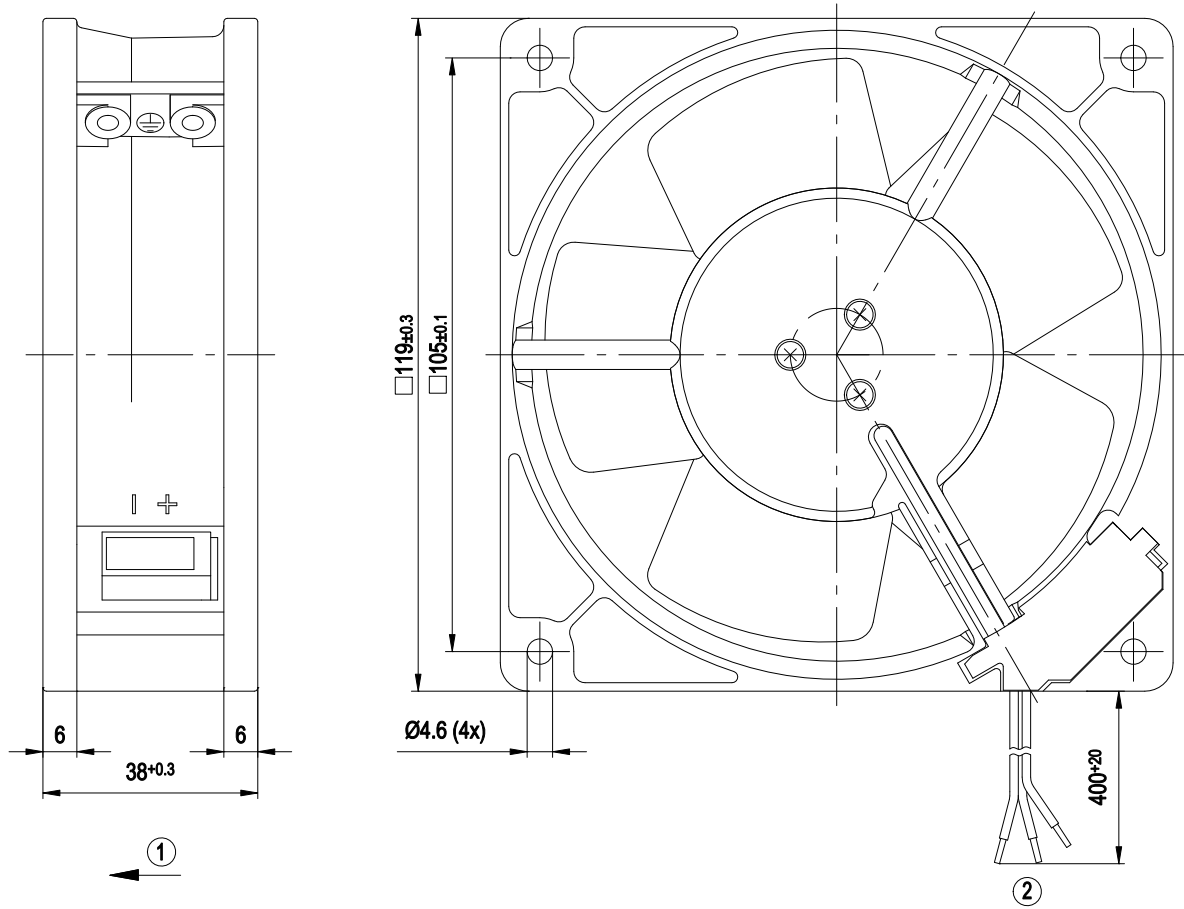

- | | |
|---|--|
| 1 | Direction of air flow "V" |
| 2 | Connection line PVC 2x AWG22, 1x AWG26; tin-plated lead tips |



Connection screen

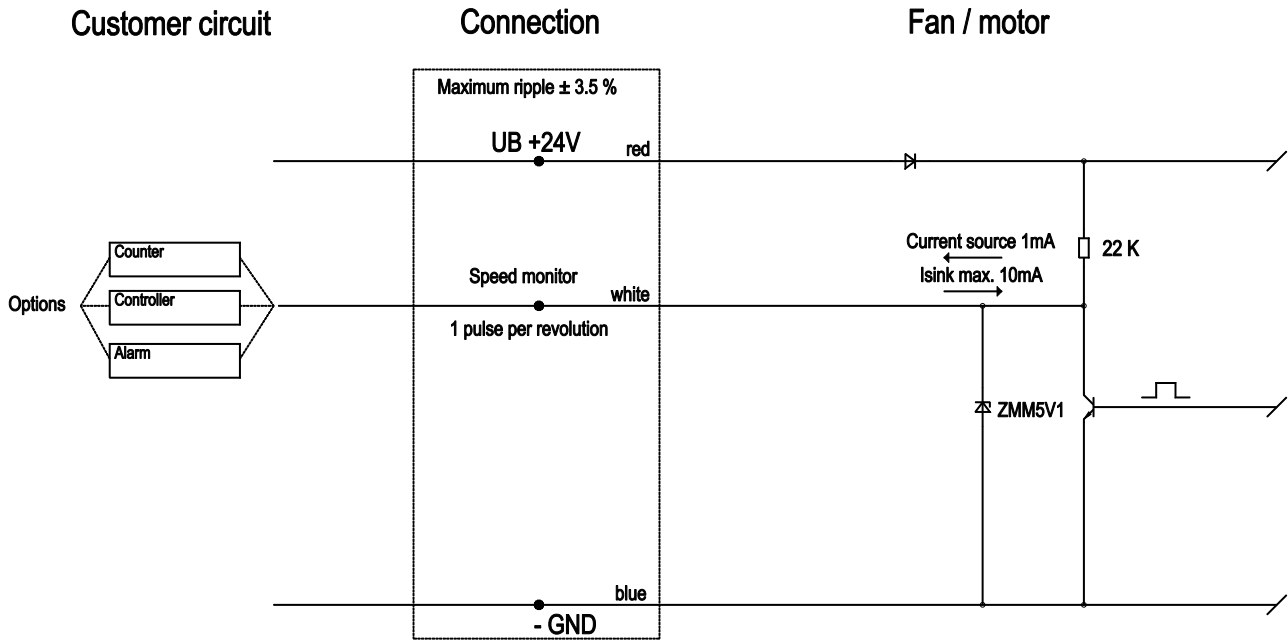

Charts: Air flow

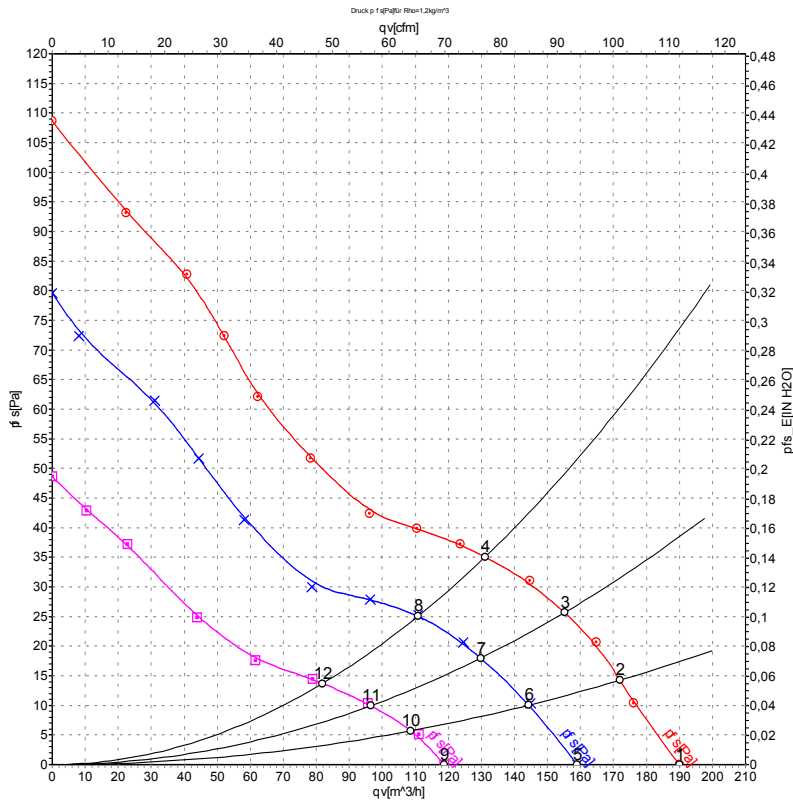

Air performance measured as per ISO 5801 Installation category A. For detailed information on the measuring set-up, please contact ebm-papst. Suction-side noise levels: L_{wA} measured as per ISO 13347 / L_{pA} measured with 1m distance to fan axis. The values given are valid under the measuring conditions mentioned above and may vary according to the actual installation situation. With any deviation from the standard set-up, the specific values have to be checked and reviewed with the unit installed.

Measured values

	U	n	P _{ed}	I	qv	p _{fs}
	V	min ⁻¹	W	A	m ³ /h	Pa
1	30	3425	6.8	0.24	190	0
2	30	3335	7.1	0.25	170	14
3	30	3270	7.4	0.26	155	26
4	30	3215	7.6	0.27	130	35
5	24	2860	4.2	0.18	160	0
6	24	2810	4.4	0.19	145	10
7	24	2755	4.5	0.20	130	18
8	24	2705	4.7	0.20	110	25
9	18	2205	2.16	0.12	120	0
10	18	2165	2.26	0.13	110	6
11	18	2125	2.35	0.13	95	10
12	18	2120	2.35	0.13	80	14

U = Supply voltage · n = Speed · P_{ed} = Power input · I = Current draw · qv = Air flow · p_{fs} = Pressure increase

