

S4E350-AR06-30

AC axial fan with guard grille for short nozzle sickled blades (S series)



ebm-papst Mulfingen GmbH & Co. KG

Bachmühle 2

74673 Mulfingen

Phone: +49 7938 81-0

Fax: +49 7938 81-110

www.ebmpapst.com

info1@de.ebmpapst.com

Nominal data

Type	S4E350-AR06-30		
Motor	M4E068-EC		
Phase		1~	1~
Nominal voltage	[V]	230	230
Frequency	[Hz]	50	60
Type of data definition		rfa	rfa
Valid for approval / standard		CE	CE
Speed	[min ⁻¹]	1365	1530
Power input	[W]	132	180
Current draw	[A]	0,58	0.8
Motor capacitor	[µF]	5	5
Capacitor voltage	[VDB]	400	400
Capacitor standard		P0 (CE)	P0 (CE)
Max. back pressure	[Pa]	90	65
Max. ambient temperature	[°C]	60	50
Air flow	[m ³ /h]	3250	3640
Back pressure	[Pa]	0	0
Sound pressure level	[dB(A)]	64	67

ml = max. load · me = max. efficiency · rfa = running at free air · cs = customer specs · cu = customer unit
Subject to alterations

Technical features

Size	350 mm
Operation mode	Continuous operation (S1)
Direction of rotation	Counter-clockwise, seen on rotor
Direction of air flow	"V"
Insulation class	"F"
Cable exit	Axial
Bearing motor	Ball bearing
Mass	3.6 kg
Material of electronics housing	Rotor: Coated in black
Material of impeller	Sheet steel, coated in black
Motor protection	Thermal overload protector (TOP) wired internally
Product conforming to standard	CE
Number of blades	5
Type of protection	IP 44 - depending on position
Protection class	I
Approval	CCC

S4E350-AR06-30

AC axial fan with guard grille for short nozzle sickled blades (S series)

Product drawing

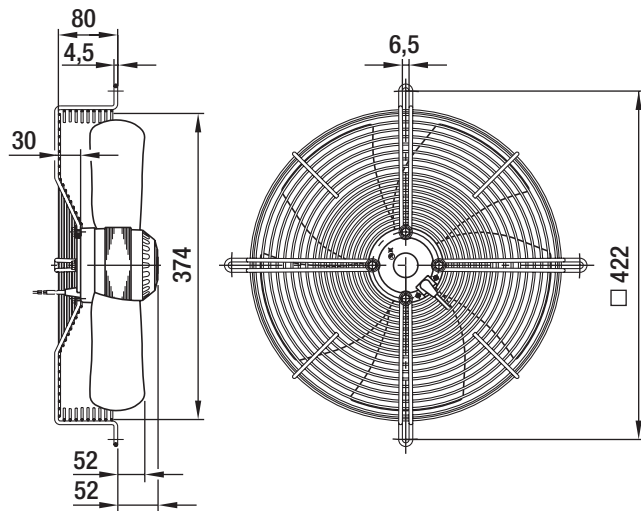

Connection screen

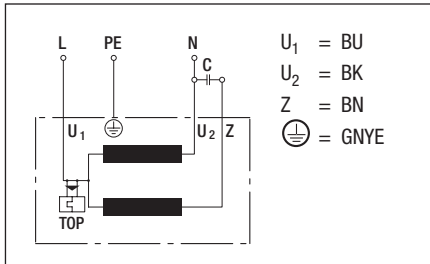

Charts: Air flow 50 Hz

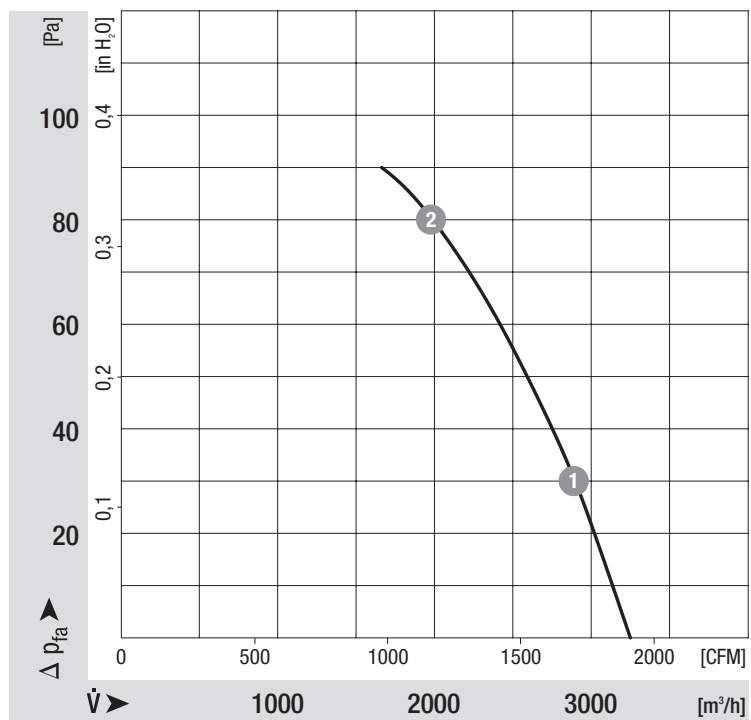

Measured values

	n	P ₁	I
	[min ⁻¹]	[W]	[A]
1	1335	142	0.43
2	1260	166	0.43

Charts: Air flow 60 Hz

