

# BCI motor.

BCI-42.XX



- Direct current motor with permanent magnets made of ceramic bound ferrite
- Mechanical commutation through 8-piece collector
- Closed steel motor housing with die-cast zinc bearing flanges
- Operation in both directions of rotation
- Service life 3 000 h for continuous operation (S1)
- Insulation class B
- Protection class IP 40, optionally higher

Nominal data					
Type		BCI-42.25-A00	BCI-42.25-B00	BCI-42.40-A00	BCI-42.40-B00
Nominal voltage ( $U_{BN}$ )	V DC	12	24	12	24
Nominal speed ( $n_N$ )*	rpm	3 300	3 300	3 100	3 100
Nominal torque ( $M_N$ )*	mNm	38	38	57	57
Nominal current ( $I_{BN}$ )*	A	1.90	0.96	2.50	1.10
Nominal output power ( $P_N$ )*	W	13	13	19	19
Rated efficiency, approx. ( $\eta_N$ )	%	60	60	63	70
Free-running speed ( $n_f$ )	rpm	4 000	3 900	3 850	3 600
Free-running current ( $I_{fL}$ )	A	0.30	0.19	0.27	0.17
Starting torque ( $M_A$ )	mNm	200	190	330	320
Starting current ( $I_A$ )	A	7.60	4.00	11.2	5.90
Induced voltage ( $U_{imax}$ )	V/1 000 rpm	2.74	5.50	3.04	6.40
Connection resistance ( $R_v$ )	Ohm	1.54	6.05	1.08	4.10
Connection inductance ( $L_v$ )	mH	2.20	8.90	1.20	5.10
Rotor moment of inertia ( $J_R$ )	kgm <sup>2</sup> x 10 <sup>-6</sup>	7.40	7.40	11.5	11.5
Heat resistance ( $R_{th}$ )	K/W	4.80	4.80	4.75	4.75
Protection class**		IP 40			
Permissible ambient temperature range ( $T_U$ )	°C	0 ... +40			
Weight	kg	0.40	0.40	0.50	0.50
Order No.		on request	931 4225 001	on request	931 4240 062
Subject to alterations		* at $T_U$ max. 40°C ** Classification of protection class refers to installed state with sealing on the flange side			

## Characteristic curve

BCI-42.25, 24 V (at 25°C)

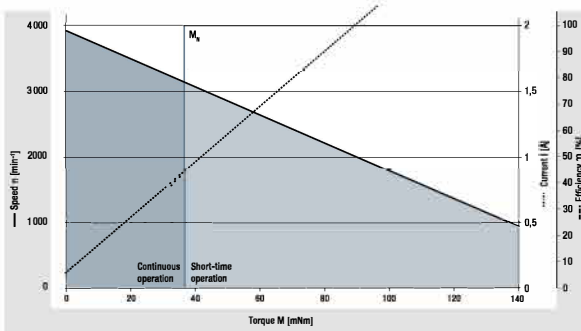

<sup>1)</sup> Nominal data, see table

BCI-42.40, 24 V (at 25°C)

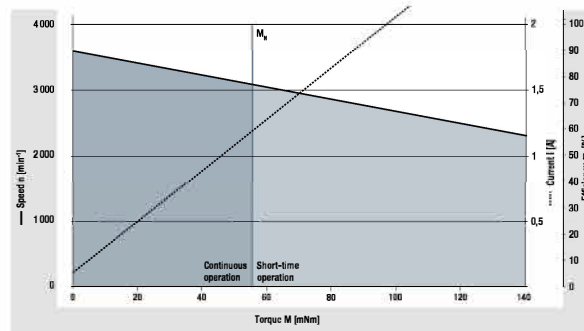

<sup>1)</sup> Nominal data, see table

**Technical drawing**

Image standard type / All dimensions in mm

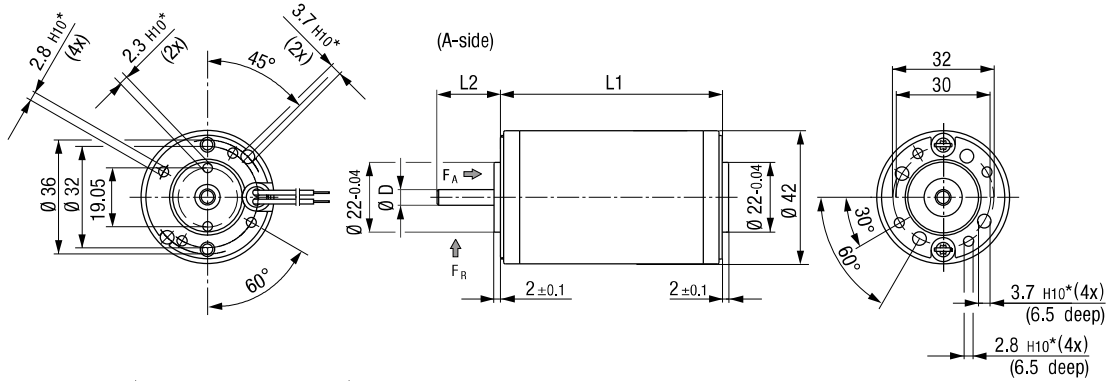

Shaft dimensions	$\emptyset D$ (A-side)	L2 (A-side)	$\emptyset D$ (B-side)	L (B-side)
Standard type	$5_{g5}$	20,0 mm	--	--
Preferred type	$5_{g5}$	14,5 mm	$5_{g5}$	15 mm

Type	L1
BCI-42,25	$70 \pm 0.5$
BCI-42,40	$85 \pm 0.5$

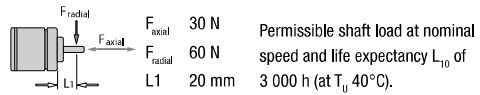

\* Blind holes for thread-forming screws according to DIN 7500

**Electrical connection**

**Connection cable**

Color	Function	
red	Power supply (+)	Cable length $300 \pm 30$ from motor Cable end $7 \pm 2$ stripped and tin-coated
black	GND (-)	

Change of the rotating direction is possible by polarity reversal of the wires

**Modular construction kit**

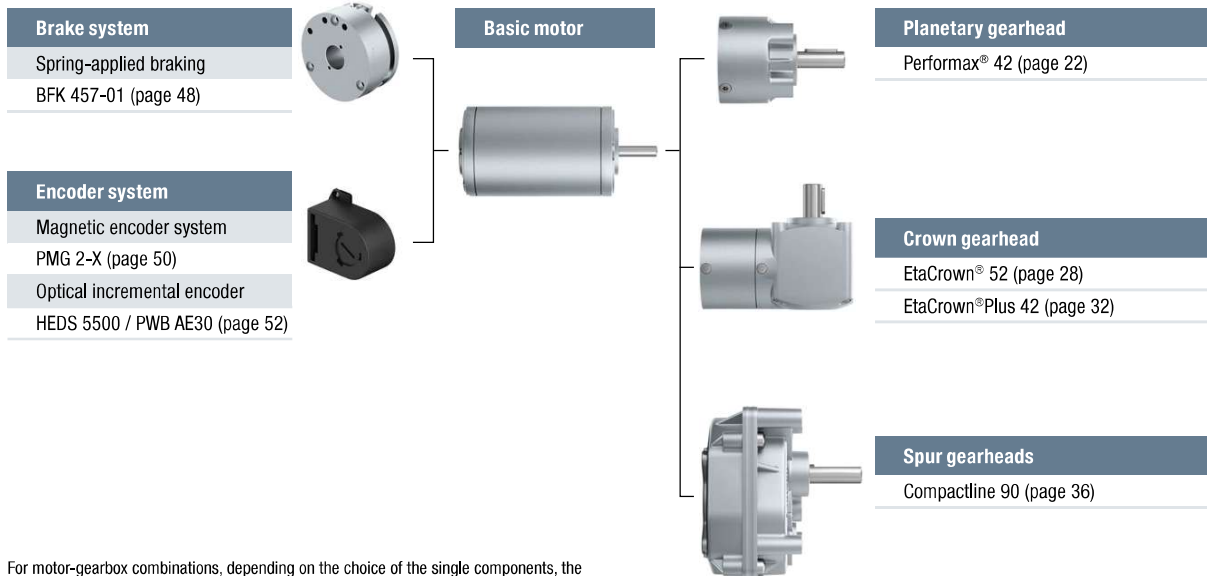

For motor-gearbox combinations, depending on the choice of the single components, the maximum allowable torque (gearbox) can be exceeded or respectively not reached.