

LV8968BBUW

Multi-purpose BLDC Gate-driver for Automotive

Overview

The LV8968BB is a 3-phase BLDC/PMSM pre-driver with integrated phase voltage sensing and logic level FET compatibility. The wide operating voltage range and AEC-Q100 qualification make this device ideal for automotive applications. Six gate drivers provide 400 mA (typ) gate current to external power bridges allowing use of low resistance power FETs as well as logic level FETs. All FETs are protected against over-current, short-circuit, over-temperature and gate under-voltage. A multitude of protection and monitoring features make this device suitable for ISO26262 applications. Three independent low-side source pins allow multiple shunt measurement.

The device also includes a programmable linear regulator, a fast current-sense amplifier and a window watchdog for microcontroller support. The SPI interface allows for real time parameter setup and diagnostics. Critical system parameters can be programmed into non-volatile OTP memory.

Junction temperature tolerance up to 175°C and control via wide level WAKE and PWM signals make the LV8968BB an ideal motor pre-driver for automotive applications such as engine cooling fans, fuel, oil, and hydraulic pumps.

Features

- Full Drive Power from 8 V to 28 V Supply Voltage with Transient Tolerance from 4.5 V to 40 V
- Extended Voltage Range from 6 V to 33 V Using Logic-level Mode
- Up to 30 kHz Motor PWM with Individual Six Gate Control or Drive-3 Mode with Integrated Programmable Dead-Time
- 5 V / 3.3 V Linear Regulator for External Loads up to 50 mA
- Extensive System Protection Features Including:
 - ◆ Drain-Source Short Detection for External FET
 - ◆ Over-current Shutoff
 - ◆ Low Gate Voltage Warning
 - ◆ Over-temperature Warning and Shutoff
 - ◆ Over / Under-voltage Protection
- SPI Interface for Parameter Setup and Diagnostic Access, Dynamic Access to Dead-Time, Amplifier Gain, and Short Circuit Levels
- Non-Volatile (OTP) Memory for Storing Critical System Parameters
- Wide Voltage Enable Line and PWM Interface
- Integrated Window Watchdog Timer Function
- AEC-Q100 Qualified and PPAP Capable
- Thermally Efficient Exposed Die 48 Pin SQFP Package for Transient Operation Up to 175°C
- These Devices are Pb-Free, Halogen Free/BFR Free and are RoHS Compliant



ON Semiconductor®

www.onsemi.com

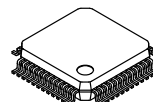

SPQFP48
CASE 131AN

MARKING DIAGRAM

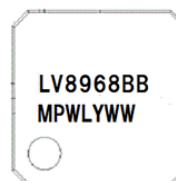

LV8968BB
MPWLYWW

MP = Assembly Location
WL = Wafer Lot
Y = Year
WW = Work Week

ORDERING INFORMATION

| Device | Package | Shipping† |
|---------------|---|-----------------------|
| LV8968BBUWR2G | SPQFP48K (Pb-Free / Halogen Free) | 2500 / Tape & Reel |

†For information on tape and reel specifications, including part orientation and tape sizes, please refer to our Tape and Reel Packaging Specification Brochure, BRD8011/D.

SAFETY DESIGN ASILB

ASILB Product developed in compliance with ISO26262 for which a complete safety package is available.

Typical Applications

- Automotive Fuel, Oil, Water or Hydraulic Pumps
- Automotive Actuators
- Automotive HVAC and Cooling Fans
- Battery Operated Hand Power Tools
- White Goods

LV8968BBUW

INTERNAL EQUIVALENT BLOCK DIAGRAM AND APPLICATION CIRCUIT

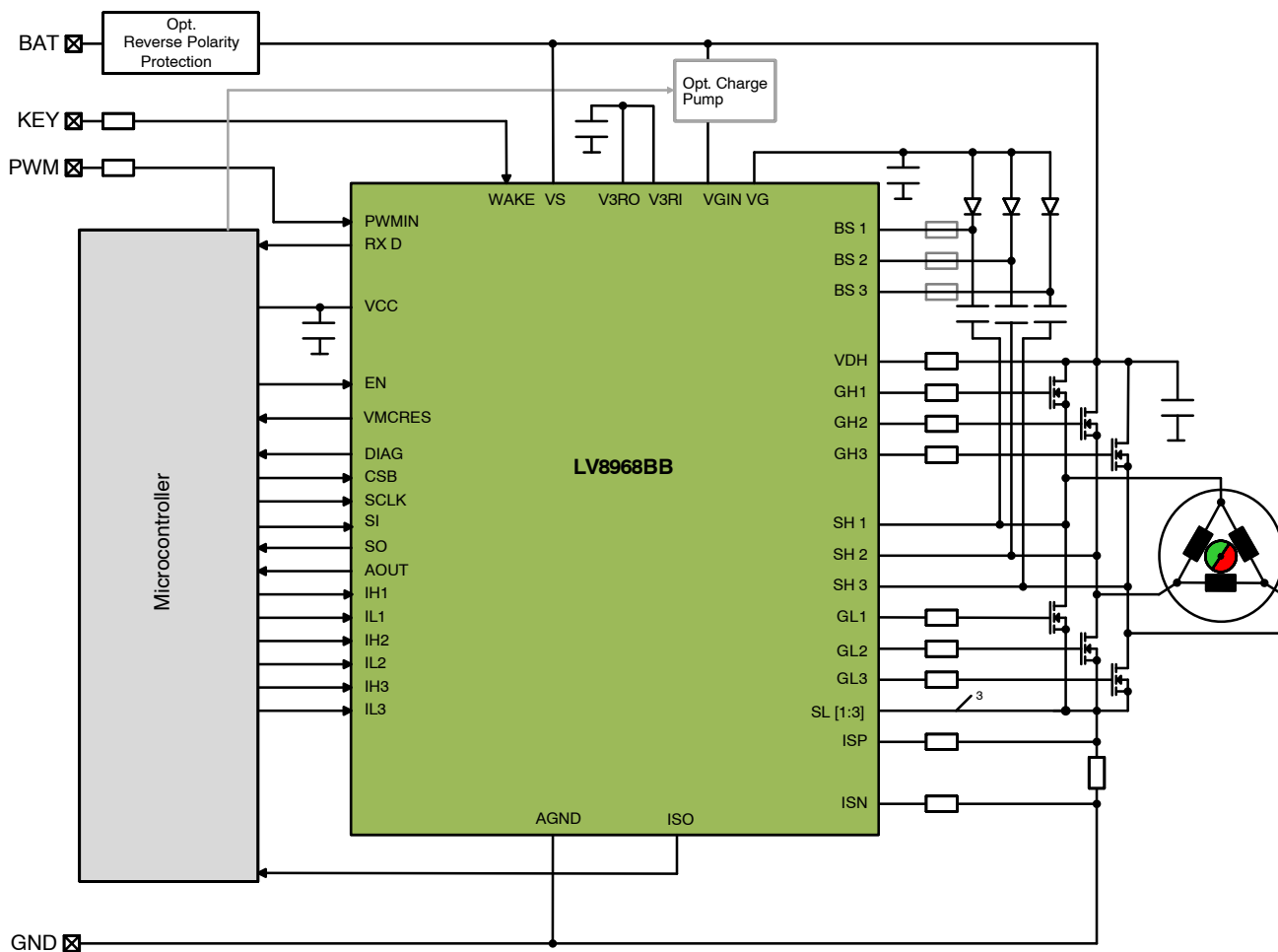

Figure 1. Typical Application Diagram

LV8968BBUW

PIN ASSIGNMENT

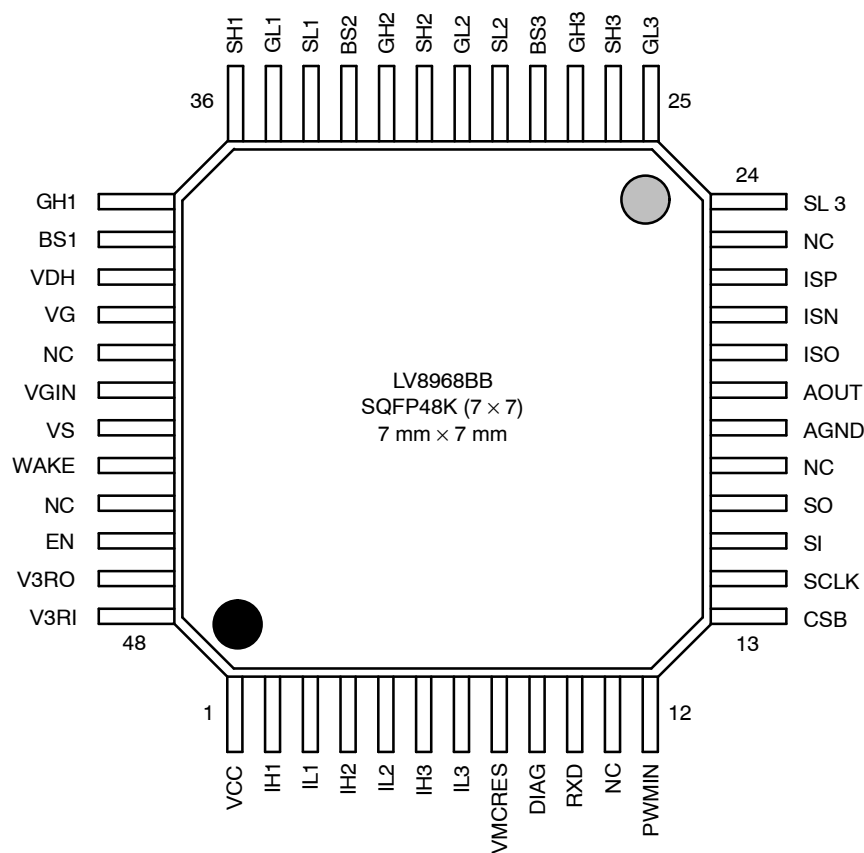

Figure 2. LV8968BB Pinout

Table 1. PIN ASSIGNMENTS & DESCRIPTION

| Name | No. | Description |
|--------|-----|---|
| VCC | 1 | 5 V or 3.3 V linear regulator output. (Selected by SPI register setting) Can provide up to 50 mA. |
| IH1 | 2 | Active high, digital control input to activate GH1. |
| IL1 | 3 | Active low, digital control input to activate GL1. |
| IH2 | 4 | Active high, digital control input to activate GH2. |
| IL2 | 5 | Active low, digital control input to activate GL2. |
| IH3 | 6 | Active high, digital control input to activate GH3. |
| IL3 | 7 | Active low, digital control input to activate GL3. |
| VMCRES | 8 | Open drain reset output for the microcontroller. Goes low for VCC under-voltage fault, optionally for watchdog reset and thermal shutdown. |
| DIAG | 9 | Open drain error or diagnostic output to be connected to microcontroller interrupt line. DIAG functionality is defined by internal register settings. |
| RXD | 10 | Open drain PWM data output to microcontroller. |
| NC | 11 | No connection. |
| PWMIN | 12 | Input for battery level control signal. The digital level of PWMIN appears on RXD. |
| CSB | 13 | High voltage level translator. Digital level is active low, digital SPI interface chip selection pin. |
| SCLK | 14 | SPI interface clock input pin. SI data is latched during the rising edge. |

LV8968BBUW

Table 1. PIN ASSIGNMENTS & DESCRIPTION (continued)

| Name | No. | Description |
|------|-----|---|
| SI | 15 | SPI interface serial data input pin. |
| SO | 16 | SPI interface serial data output pin. High level is pulled to VCC. |
| NC | 17 | No connection. |
| AGND | 18 | Ground pin. |
| AOUT | 19 | Output for various internal analog signals. Actual signal is selected via SPI register. Scaled to 2 V full scale range. |
| ISO | 20 | Output pin for current sense amplifier. Connect to AD converter input of the microcontroller for current sensing. Gain, reference, and over-current threshold is programmable via SPI register. Full scale range = 2 V. |
| ISN | 21 | Current sense amp minus input pin. Connect this pin to the GND side of the shunt resistor with Kelvin leads. |
| ISP | 22 | Current sense amp plus input pin. Connect this through to top side of shunt resistor with Kelvin leads. |
| NC | 23 | No connection. |
| SL3 | 24 | Low side source connection of the power stage. Return path for gate current of GL3. Connect to source of FET controlled by IL3 or to common source of the power stage. |
| GL3 | 25 | Gate driver output for low side FETs. Switches voltage level between VG and SL3. Use at least 10 Ω gate resistors to protect against current spikes. |
| SH3 | 26 | Connection for the motor phase terminal controlled by GH3 and GL3. Return path for high-side drivers and input for back EMF sensing. |
| GH3 | 27 | Gate driver output for high side FETs. Switches voltage level between BS3 and SH3. Use at least 10 Ω gate resistors to protect against current spikes. |
| BS3 | 28 | Supply pin for high side driver GH3. Needs a bootstrap capacitor to SH3 and a diode in reverse connection to VG. |
| SL2 | 29 | Low side source connection of the power stage. Return path for gate current of GL2. Connect to source of FET controlled by IL2 or to common source of the power stage. |
| GL2 | 30 | Gate driver output for low side FETs. Switches voltage level between VG and SL2. Use at least 10 Ω gate resistors to protect against current spikes. |
| SH2 | 31 | Connection for the motor phase terminal controlled by GH2 and GL2. Return path for high-side drivers and input for back EMF sensing. |
| GH2 | 32 | Gate driver output for high side FETs. Switches voltage level between BS2 and SH2. Use at least 10 Ω gate resistors to protect against current spikes. |
| BS2 | 33 | Supply pin for high side driver GH2. Needs a bootstrap capacitor to SH2 and a diode in reverse connection to VG. |
| SL1 | 34 | Low side source connection of the power stage. Return path for gate current of GL1. Connect to source of FET controlled by IL1 or to common source of the power stage. |
| GL1 | 35 | Gate driver output for low side FETs. Switches voltage level between VG and SL1. Use at least 10 Ω gate resistors to protect against current spikes. |
| SH1 | 36 | Connection for the motor phase terminal controlled by GH1 and GL1. Return path for high-side drivers and input for back EMF sensing. |
| GH1 | 37 | Gate driver output for high side FETs. Switches voltage level between BS1 and SH1. Use at least 10 Ω gate resistors to protect against current spikes. |
| BS1 | 38 | Supply pin for high side driver GH1. Needs a bootstrap capacitor to SH1 and a diode in reverse connection to VG. |
| VDH | 39 | Sense input for supply voltage and short circuit detection of high side power FETs. Connect through 100 Ω resistor to common drain of the power bridge. |
| VG | 40 | Power supply pin for low-side gate drive GL[1–3] directly and GH[1–3] through bootstrap circuit. Connect decoupling capacitor between VG and GND. |
| NC | 41 | No Connection. |

LV8968BBUW

Table 1. PIN ASSIGNMENTS & DESCRIPTION (continued)

| Name | No. | Description |
|-------------|------------|---|
| VGIN | 42 | Gate supply input. Normally shorted to VS. Insert a charge pump circuit between VS and VGIN if low voltage operation is required. |
| VS | 43 | Power supply pin. |
| WAKE | 44 | WAKE up pin for internal power supply. "H" => Operating mode, "L" or "Open" => Sleep mode. |
| NC | 45 | No connection. |
| EN | 46 | Active high digital input. A high on EN will activate the outputs. EN can be used as a hold input to allow an external microcontroller to keep the IC operating even if WAKE is low. A falling edge on EN clears the error flags. |
| V3RO | 47 | Internal regulator output pin. Connect capacitor between this pin and GND. |
| V3RI | 48 | Internal regulator feedback pin (Control circuit and Logic power supply). Connect to V3RO pin. Do not load beyond 1 mA. |

LV8968BBUW

PIN FUNCTIONALITY

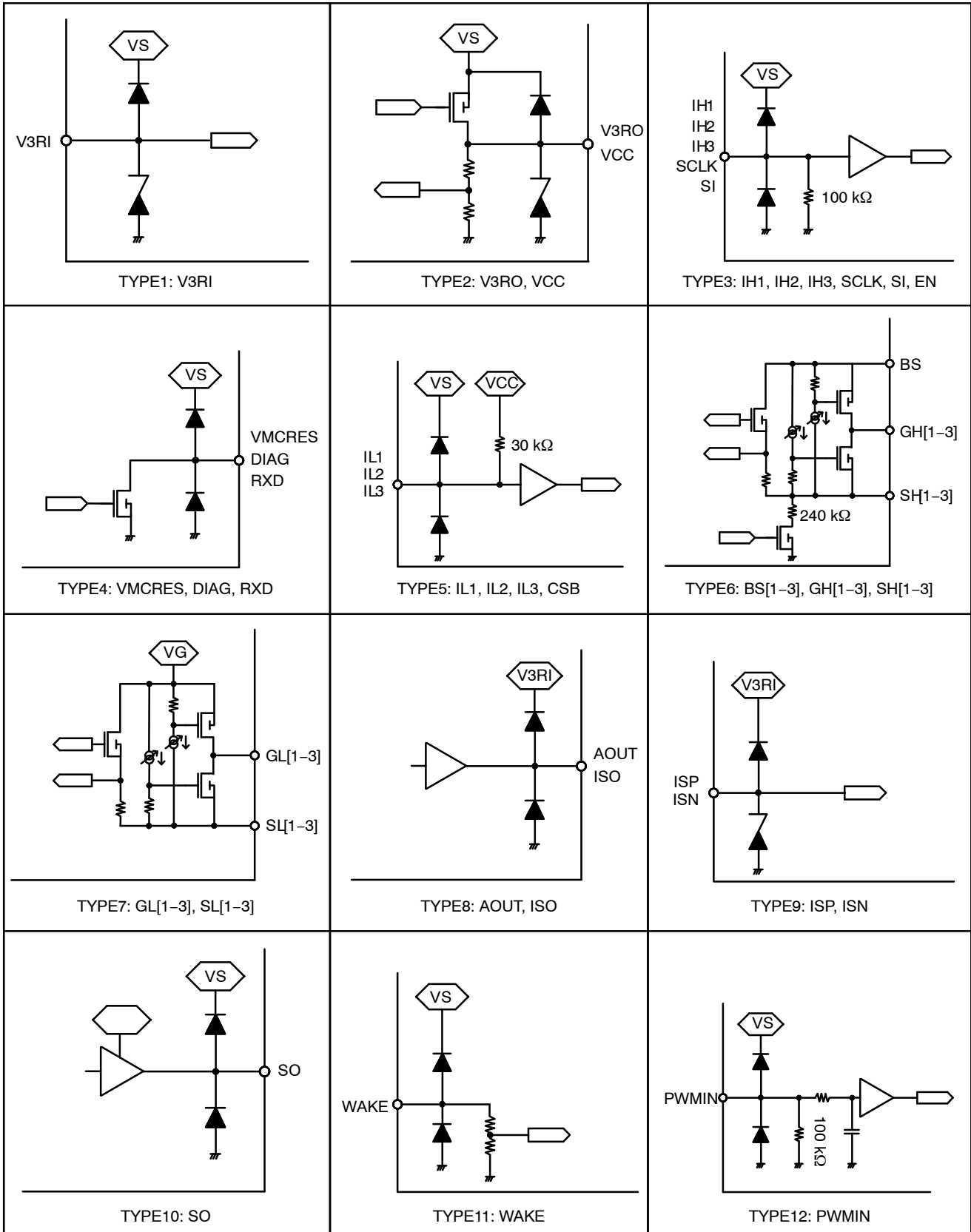

LV8968BBUW

PIN FUNCTIONALITY (continued)

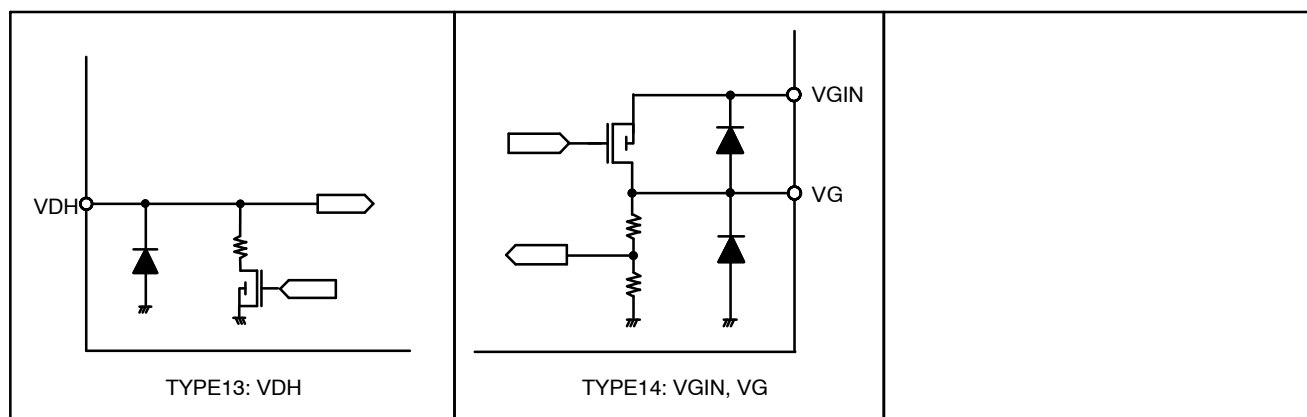

Figure 3. Pin Functionality

Table 2. ABSOLUTE MAXIMUM RATINGS

| Parameter | Pins | Ratings | Unit |
|-----------------------------------|-------------------------------------|------------------------|------|
| Supply Voltage | VS, VDH, VGIN | -0.3 to 40 | V |
| Gate Voltage to GND | VG | -0.3 to 40 | V |
| Bootstrap to GND | BS[1-3] | -0.3 to 40 | V |
| Bootstrap to SH[1-3] | BS[1-3] | -0.3 to 40 | V |
| Logic Power Supply | V3RI, V3RO | -0.3 to 3.6 | V |
| 5 V Regulator Voltage | VCC | -0.3 to 5.5 | V |
| VS Level Signal Voltage | WAKE, PWMIN | -0.3 to 40 | V |
| Digital Inputs | CSB, EN, SCLK, SI, IH[1-3], IL[1-3] | -0.3 to 40 | V |
| Open Drain Voltage | VMCRES, RXD, DIAG | -0.3 to 40 | V |
| Digital Output Voltage | SO | -0.3 to $V_{VCC}+0.3$ | V |
| Current Sense Input | ISP, ISN | -3 to $V_{V3RI}+0.3$ | V |
| Analog Output | ISO, AOUT | -0.3 to $V_{V3RO}+0.3$ | V |
| High-side Output to GND | GH[1-3] | -3 to 40 | V |
| Motor Phase | SH[1-3] | -3 to 40 | V |
| Low-side Output to GND | GL[1-3] | -3 to 40 | V |
| Low-side Source Pin to GND | SL[1-3]] | -3 to 40 | V |
| Voltage between HS Gate and Phase | GH[n] to SH[n] for n = {1,2,3} | -0.3 to 20 | V |
| Allowable Power SQFP48K | at 70°C | 2430 | mW |
| Thermal Resistance (JESD51-7) | J_A = Junction Ambient | 33 | °C/W |
| | J_C = Junction Case | 2 | °C/W |
| Storage Temperature | | -55 to 150 | °C |
| Junction Temperature | | -40 to 150 | °C |
| | (Note 1) | 150 to 175 | °C |
| ESD Human Body Model | AEC Q100_002 | 2 | kV |
| ESD Charge Device Model | AEC Q100_011 | 750 | V |

Stresses exceeding those listed in the Maximum Ratings table may damage the device. If any of these limits are exceeded, device functionality should not be assumed, damage may occur and reliability may be affected.

1. Operation outside the Operating Junction temperature is not guaranteed. Operation above 150°C should not be considered without a written agreement from ON Semiconductor Engineering staff.

LV8968BBUW

Table 3. ELECTRICAL CHARACTERISTICS

(Valid at a junction temperature range from -40°C to 150°C, for supply Voltage $8.0\text{ V} \leq V_S \leq 25\text{ V}$ unless otherwise specified. Typical values at 25°C and $V_S = 12\text{ V}$ unless specified otherwise)

| Parameter | Symbol | Condition | Min. | Typ. | Max. | Unit |
|---------------------------|--------|---|------------------|------|------------------|------|
| INTERNAL REGULATOR | | | | | | |
| VS supply voltage range | VSNO | Normal mode (Note 2) | 8 | 12 | 28 | V |
| | VSLO | Logic level mode | 6 | | 33 | V |
| | VSLOF | Full logic functionality, driver stage off. (t < 400 ms) (Note 3) | 4.5 | | 40 | V |
| VS supply current | ISTBY | Standby mode VS & VGIN shorted VS = 6 V~25 V | 7 | 11 | 16 | mA |
| | ISLEEP | Sleep mode at 25°C VS & VGIN shorted | | 25 | 50 | μA |
| WAKE input voltage | VTHWKL | Low level | 0 | | 1.3 | V |
| | VTHWKH | High level | 2.7 | | VS | V |
| WAKE pulldown resistor | RPDWK | | 50 | 100 | 200 | kΩ |
| PWMIN switching levels | VTHPIL | Low level | 0 | | $0.4 \times V_S$ | V |
| | VTHPIH | High level | $0.6 \times V_S$ | | VS | V |
| PWMIN pulldown resistor | RPDPI | | 50 | 100 | 200 | kΩ |
| PWMIN frequency range | FPWMIN | | 0 | | 30 | kHz |

INTERNAL REGULATOR

| | | | | | | |
|---------------------|------|--|-------|-----|-------|---|
| V3RO output voltage | V3RO | | 3.135 | 3.3 | 3.465 | V |
|---------------------|------|--|-------|-----|-------|---|

VCC CONSTANT VOLTAGE OUTPUT

| | | | | | | |
|----------------------|---------|---------------------------------------|------|-----|------|----|
| Output voltage 5V | VC5RO | REGSEL = 1, No load | 4.9 | 5.0 | 5.1 | V |
| Output voltage 3.3V | VC3RO | REGSEL = 0, No load | 3.23 | 3.3 | 3.37 | V |
| | VC3RL | VS = 4.5 V, I _{VCC} = -50 mA | 3.0 | | | V |
| Voltage regulation | VCCVR | | | | 50 | mV |
| Load regulation | VCCLR | I _o = -5 mA to -50 mA | | | 80 | mV |
| Output current limit | VCCILIM | | 50 | | 180 | mA |

GATE DRIVERS

| | | | | | | |
|--|---------|---|-----|----|-----|----|
| Low-side Rdson to SL[1-3] | RONLSSK | "L" level I _o = 10 mA | | 6 | 15 | Ω |
| Low-side Rdson to SH[1-3] | RONLSSC | "H" level I _o = -10 mA | | 12 | 22 | Ω |
| High-side Rdson to SH[1-3] | RONHSSK | "L" level I _o = 10 mA | | 6 | 15 | Ω |
| High-side Rdson to BS[1-3] | RONHSSC | "H" level I _o = -10 mA | | 12 | 22 | Ω |
| Propagation delay ON | PDON | 50% IHx to 20% GHx. Cl _{oad} = 0 nF | | | 120 | nS |
| Propagation delay OFF | PDOFF | 50% IHx to 80% GHx. Cl _{oad} = 0 nF | | | 120 | nS |
| Propagation delay ON Difference GH[1-3],GL[1-3] | DPDON | a.3 phase difference of GH1, GH2 and GH3 | -20 | | 20 | nS |
| | | b.3 phase difference of GL1, GL2 and GL3 | | | | |
| Propagation delay OFF Difference GH[1-3],GL[1-3] | DPDOFF | a.3 phase difference of GH1, GH2 and GH3 | -20 | | 20 | nS |
| | | b.3 phase difference of GL1, GL2 and GL3 | | | | |

BS VOLTAGE

| | | | | | | |
|---------------------|------|--|--|--|-----|----|
| BS internal current | IBSC | | | | 800 | μA |
|---------------------|------|--|--|--|-----|----|

LV8968BBUW

Table 3. ELECTRICAL CHARACTERISTICS (continued)

(Valid at a junction temperature range from -40°C to 150°C , for supply Voltage $8.0\text{ V} \leq V_S \leq 25\text{ V}$ unless otherwise specified.

Typical values at 25°C and $V_S = 12\text{ V}$ unless specified otherwise)

| Parameter | Symbol | Condition | Min. | Typ. | Max. | Unit |
|---------------------------------|--------|--|------|------|------|------|
| GATE VOLTAGE OUTPUT (VG) | | | | | | |
| VG output voltage | VGNO | Normal mode, $I_{VG} < 40\text{ mA}$ | 7.0 | 11.0 | 12.0 | V |
| | VGLO | Logic level mode | 5 | 6 | 7 | V |
| | VGOL | $V_S = 6\text{ V}$, $I_{VG} < 30\text{ mA}$ | 5 | | | |
| VG current limit | VGILIM | | 40 | | 180 | mA |

BEMF DETECTION

| | | | | | | |
|--|---------|-----------------------------------|------|------|-----|------------------------------|
| BEMF divider ratio | BEMFDR | | | 1/16 | | |
| BEMF divider mismatch | BEMFDM | | -2 | | 2 | % |
| BEMF divider settling time (20% – 80% FSR) | BEMFST | | | 0.5 | 2 | μs |
| VDH divider ratio | VDHDR | | | 1/32 | | |
| VDH divider settling time (20% – 80% FSR) | VDHST | | | 0.5 | 2 | μs |
| Thermal voltage | VTMPH | $T_j = 155^{\circ}$ (Note 4) | | 705 | | mV |
| Thermal slope | TEMPSL | (Note 4) | | -1.9 | | $\text{mV}/^{\circ}\text{C}$ |
| AOUT full scale range | AOFLSCR | | | | 2.1 | V |
| AOUT output resistance | RONAO | $I_{AOUT} = \pm 100\ \mu\text{A}$ | | | 200 | Ω |
| AOUT output current | IAO | | -100 | | 100 | μA |

CURRENT SENSING (ISP, ISN, ISO)

| | | | | | | |
|--|--------------|--|-------|------|-------|---------------|
| ISP, ISN input current | IISP/N | $-0.2\text{ V} \leq V_{ISP}, V_{ISN} \leq 2\text{ V}$ | -50 | | 50 | μA |
| Reference voltage ISO | VRCSA0 | $OCVR = 0$, $GAIN = 30$, $ISP = ISN = 0.2\text{ V}$ | 1.425 | 1.5 | 1.575 | V |
| | VRCSA1 | $OCVR = 1$, $GAIN = 30$, $ISP = ISN = 0.2\text{ V}$ | 0.125 | 0.2 | 0.275 | V |
| Gain | CSAG00 | $OCGAIN = 00$ | 6.53 | 7.5 | 8.63 | |
| | CSAG01 | $OCGAIN = 01$ (Note 4) | | 15 | | |
| | CSAG10 | $OCGAIN = 10$ (Note 4) | | 22.5 | | |
| | CSAG11 | $OCGAIN = 11$ | 26 | 30 | 34.3 | |
| Common mode range | CSACMR | | -0.2 | 1 | 2 | V |
| ISN, ISP differential voltage | DVCSAIN | | -200 | | 200 | mV |
| ISO full scale range | CSAFLSC R | | 0.1 | | 2.9 | V |
| Amplifier settling time (20% – 80% FSR) | CSAOST | $Gain = 7.5$, $0.25\text{ V} < V_{ISO} < 3\text{ V}$ | | | 5400 | ns |
| ISO output resistance | RCSAO | $I_{ISO} = \pm 100\ \mu\text{A}$ | | | 200 | Ω |
| ISO output current | ICSAO | | -100 | | 100 | μA |
| Over-current voltage level $V_{ISP} - V_{ISN}$ | VTHCSA00 | $OCDL = 00$ | 180 | 200 | 220 | mV |
| | VTHCSA01 | $OCDL = 01$ | 130 | 150 | 170 | mV |
| | VTHCSA1X | $OCDL = 10, 11$ | 80 | 100 | 120 | mV |

ACTIVE HIGH DIGITAL INPUTS (EN, SCLK, SI, IH[1-3])

| | | | | | | |
|--------------------------|-------|--|----------------------|-----|----------------------|------------------|
| High-level input voltage | VTAHH | | $0.8 \times V_{3RO}$ | | | V |
| Low-level input voltage | VTAHL | | | | $0.2 \times V_{3RO}$ | V |
| Pull-down resistance | RPDAH | | 50 | 100 | 200 | $\text{k}\Omega$ |

LV8968BBUW

Table 3. ELECTRICAL CHARACTERISTICS (continued)

(Valid at a junction temperature range from -40°C to 150°C , for supply Voltage $8.0\text{ V} \leq \text{VS} \leq 25\text{ V}$ unless otherwise specified.

Typical values at 25°C and $\text{VS} = 12\text{ V}$ unless specified otherwise)

| Parameter | Symbol | Condition | Min. | Typ. | Max. | Unit |
|-----------|--------|-----------|------|------|------|------|
|-----------|--------|-----------|------|------|------|------|

ACTIVE LOW DIGITAL INPUTS (CSB, IL[1-3])

| | | | | | | |
|---------------------------|-------|--|--------------------------|----|--------------------------|------------|
| High-level input voltage | VTALH | | $0.8 \times \text{V3RO}$ | | | V |
| Low-level input voltage | VTALL | | | | $0.2 \times \text{V3RO}$ | V |
| Pull-up resistance to VCC | RPDAL | | 15 | 30 | 60 | k Ω |

DIGITAL OUTPUTS (SO)

| | | | | | | |
|----------------|------|-----------------------------|-------------------------------|--|-----|---|
| Output voltage | VSOH | $\text{I}_o = -1\text{ mA}$ | $\text{V}_{\text{VCC}} - 0.2$ | | | V |
| | VSOL | $\text{I}_o = 1\text{ mA}$ | | | 0.2 | V |

OPEN DRAIN OUTPUTS (VMCRES, DIAG, RXD)

| | | | | | | |
|---------------------|-------|-----------------------------|--|--|-----|---------------|
| Output voltage | VODL | $\text{I}_o = 1\text{ mA}$ | | | 0.2 | V |
| Pin leakage current | ILKOD | $\text{V}_o = 5.5\text{ V}$ | | | 10 | μA |

WARNING AND PROTECTION

| | | | | | | |
|---|----------|------------------|------|------|------|--------------------|
| Thermal warning (Note 4) (Junction temperature) | TWT0 | TSTS = 0 | 125 | | | $^{\circ}\text{C}$ |
| | TWT1 | TSTS = 1 | 150 | | | $^{\circ}\text{C}$ |
| | HYSTW | Hysteresis | | 25 | | $^{\circ}\text{C}$ |
| Thermal shutdown (Note 4) (Junction temperature) | TSDT0 | TSTS = 0 | 150 | | | $^{\circ}\text{C}$ |
| | TSDT1 | TSTS = 1 | 175 | | | $^{\circ}\text{C}$ |
| | HYSTSD | Hysteresis | | 25 | | $^{\circ}\text{C}$ |
| VS voltage warning | VSOVTH | Over-voltage | 16 | 17 | 18 | V |
| | VSUVTH | Under-voltage | 7 | 7.5 | 8 | V |
| VDH voltage warning | VDHOVTH | Over-voltage | 25 | 26.5 | 28 | V |
| VG under-voltage | VGNUVTH | Normal mode | 5 | 6 | 7 | V |
| | VGLUVTH | Logic level mode | 3.5 | 4 | 4.5 | V |
| VCC under-voltage | VC3UVTH | REGSEL = 0 | 2.3 | | 2.7 | V |
| | VC5UVTH | REGSEL = 1 | 3.8 | | 4.2 | V |
| V3R Power on Reset | VPOR | | | | 2.7 | V |
| FET short protection level | FSDL0000 | FSDL = 0000 | 75 | 100 | 125 | mV |
| | FSDL0010 | FSDL = 0010 | 240 | 300 | 360 | mV |
| | FSDL0100 | FSDL = 0100 | 400 | 500 | 600 | mV |
| | FSDL1000 | FSDL = 1000 | 720 | 900 | 1080 | mV |
| | FSDL1111 | FSDL = 1111 | 1280 | 1600 | 1920 | mV |

WATCHDOG

| | | | | | | |
|-----------------------|-------|--------------------------|-----|-----|-------|---------------|
| WD first open window | WDFOW | WDWT[2:0] typical values | 3.2 | | 409.6 | ms |
| WD closed window time | WDCW | WDWT[2:0] typical values | 0.8 | | 102.4 | ms |
| WD open window time | WDOW | WDWT[2:0] typical values | 1.6 | | 204.8 | ms |
| WD reset duration | WDRD | | | 400 | | μs |

SPI INTERFACE

| | | | | | | |
|---------------------|------|--|--|--|-----|-----|
| SPI clock frequency | FSPI | | | | 4.5 | MHz |
|---------------------|------|--|--|--|-----|-----|

Product parametric performance is indicated in the Electrical Characteristics for the listed test conditions, unless otherwise noted. Product performance may not be indicated by the Electrical Characteristics if operated under different conditions.

2. VDH over voltage warning will be issued. See the specification of the VDH over voltage warning threshold voltage VDHOVTH.
3. Valid for limited time duration of 400 ms (Load dump)
4. Not tested in production. Verified during qualification only.

LV8968BBUW

DETAILED FUNCTIONAL DESCRIPTION

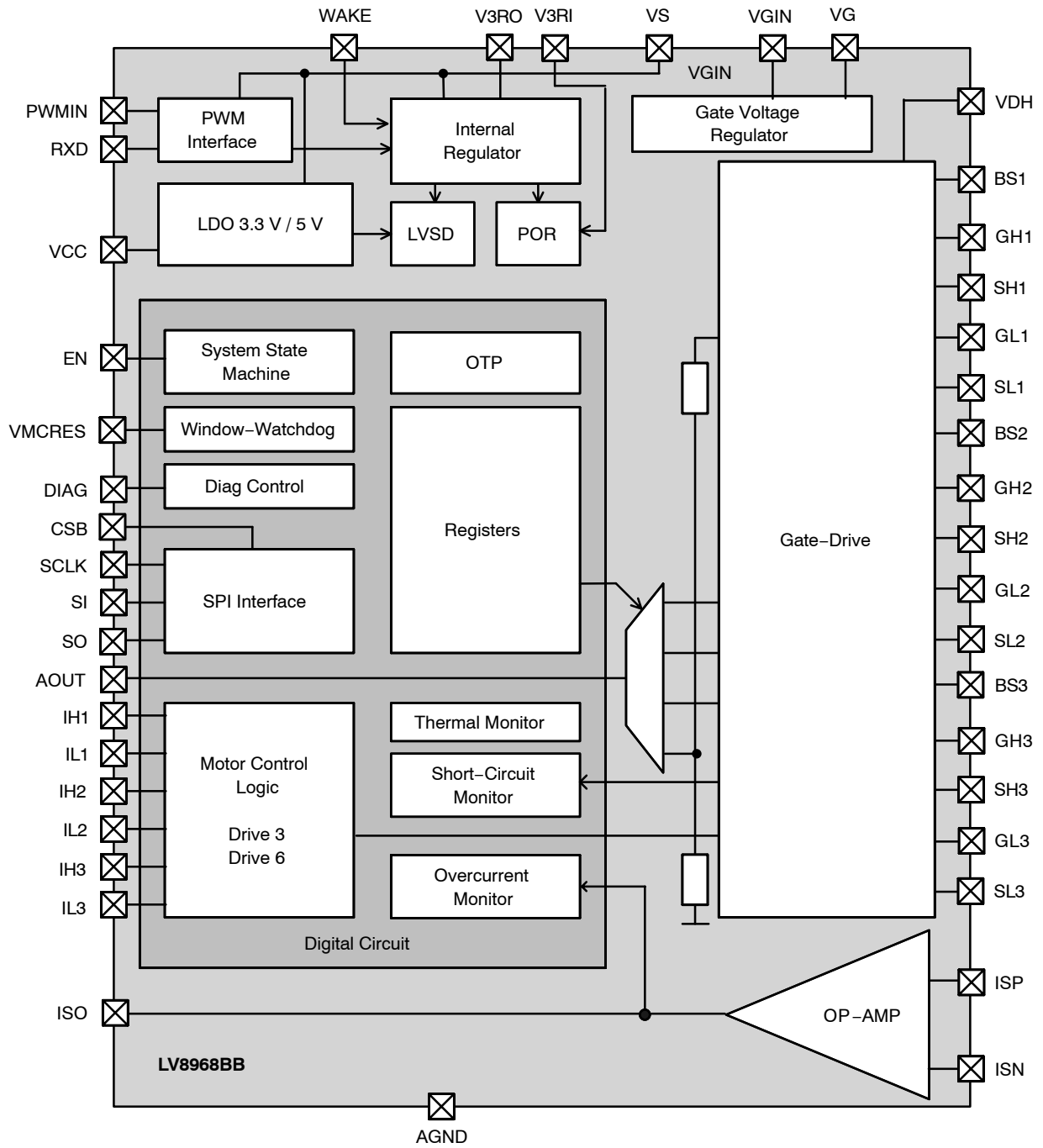

Figure 4. Block Diagram

LV8968BBUW

Chip Activation, System States and Shutdown (EN, WAKE)

Once the supply voltage VS rises above 4.5 V(min), the LV8968BB enters Sleep mode. In Sleep mode system states are controlled with pin WAKE.

Table 4. OPERATION MODES

| Mode | WAKE | EN | V3RO | Logic | VCC | VG | SPI | Drivers |
|---------|------|----|---------|--------|---------|---------|---------|---------|
| Sleep | L | NA | Disable | Reset | Disable | Disable | Disable | High-Z |
| Standby | H | L | Enable | Active | Enable | Enable | Enable | Low |
| Normal | NA | H | Enable | Active | Enable | Enable | Enable | Active |

A high level on WAKE > 2.7 V(max) activates the IC from sleep mode and enables the internal linear regulator at V3RO. Once the voltage on V3RO as sensed on V3RI has passed the power on reset (POR) threshold the system oscillator starts, and after 3.2 μ s(typ) releases the internal digital reset. OTP register contents are loaded into the system registers defining the power on state of the LV8968BB and the VCC regulator voltage.

VCC is powering up next, holding the CPU reset line VMCRES low until VCC passes its under-voltage level. During the entire wake-up sequence of 1.05 ms(typ) DIAG is masked for VG under-voltage. After wake-up is complete, the IC enters Standby mode and DIAG is

activated to display internal errors. During Standby mode full SPI access is possible.

Note that if the CPU watchdog was enabled via OTP, a VMCRES low will be asserted after 410 ms(typ) unless the watchdog is being triggered properly. See section “**Watchdog**”.

A high on EN takes the LV8968BB from Standby to Normal mode. Normal mode allows motor control and the IC accepts control inputs via the motor control pins IH[1-3], IL[1-3]. A low on EN disables the motor stage regardless of the PWM input and returns the part back to Standby mode.

The IC is shut down by taking WAKE below 1.3 V(min) if EN is low. If EN is high, a low on WAKE will be ignored until the microcontroller pulls EN low.

LV8968BBUW

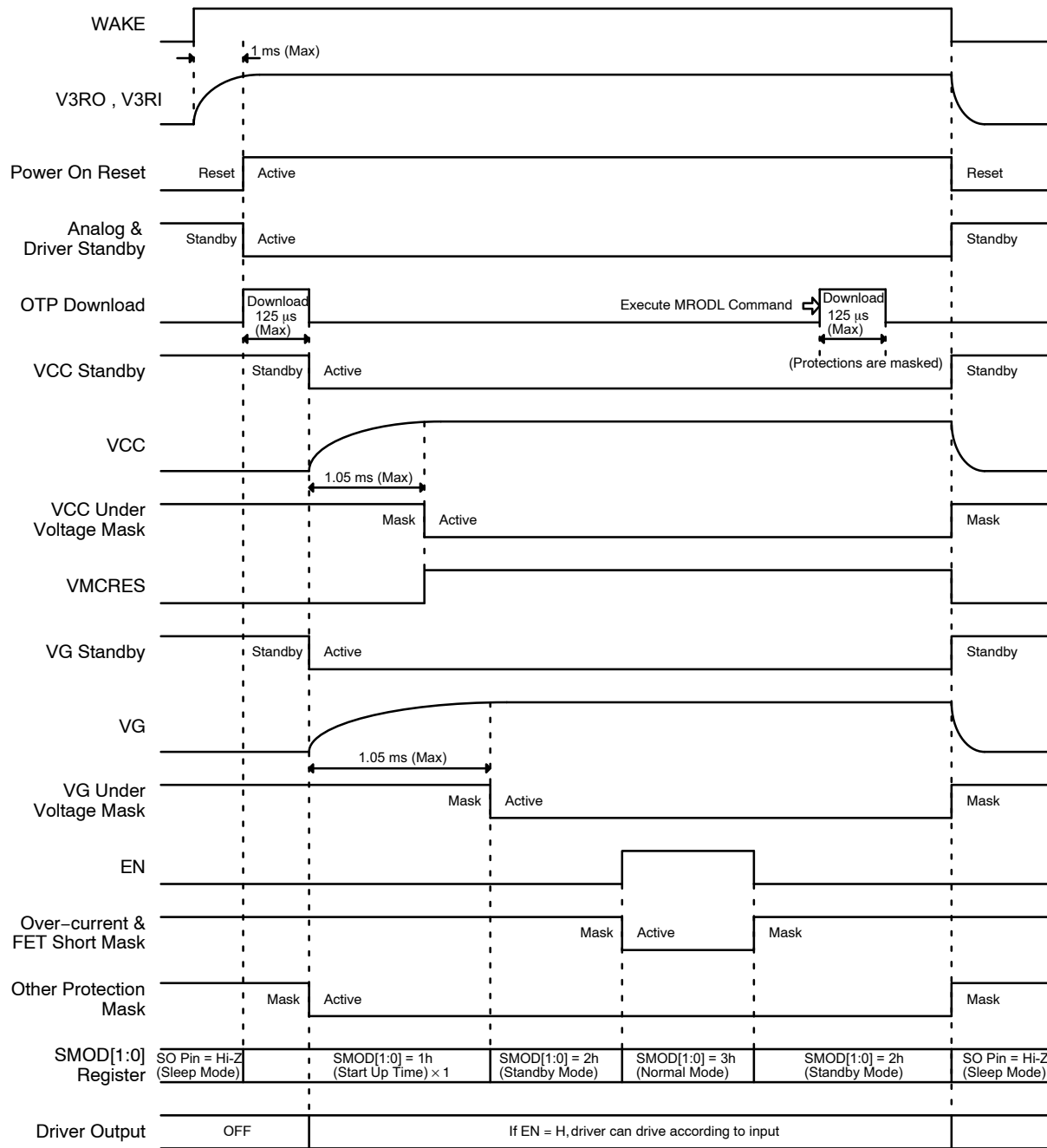

NOTE: Even if EN = H, driver status is not changed to normal mode.

Figure 5. Powerup and Shutdown Timing

Operating Voltage Range

Normal operation with full functionality is guaranteed from 8 V to 25 V. The device will operate from 4.5 V to 40 V with limited performance:

Shutdown: $VS < 4.5\text{ V}$

The IC will be off. Gate drivers is Hi-Z.

Under-voltage: $4.5\text{ V} < VS < 6\text{ V}$

VS under-voltage warning will be flagged. VG under-voltage warning may be asserted. If VCC is programmed to provide 3.3 V to the microcontroller, it will be supplied. If motor operation is required during Undervoltage, see section below "Motor Operation during Under-voltage".

Low Voltage: $6\text{ V} < VS < 8\text{ V}$

VS under-voltage warning will be flagged. VG under-voltage warning may be asserted. VCC will provide power to the microcontroller. The motor can operate but may be in low gate enhancement mode if standard level FETs are used. If full enhancement is required, see section below "Gate Voltage Regulator (VGIN, VG)"

Normal: $8\text{ V} < VS < 16\text{ V}$

Normal operation.

High Voltage: Operation $16\text{ V} < VS < 25\text{ V}$

Normal operation. VS over-voltage warning will be flagged.

Over-voltage: $25\text{ V} < VS < 40\text{ V}$

VDH over-voltage warning will be flagged. The driver stage can be programmed to let the motor freewheel to protect the bootstrap circuitry at BS[1-3] from overstress. This works if the motor is not operating in field weakening.

In case of active braking, or field weakening operation, the microcontroller will have to react to a VDH over-voltage warning by either disabling the driver stage or activating all low side FETs to brake the motor. The maximum allowable VS level for motor operation is $40\text{ V} - V_{VGmax} = 28\text{ V}$ or 33 V depending on the state of register VGVSEL. For additional protection add zener diodes to the bootstrap pins.

Motor Operation during Under-voltage

An under-voltage charge pump is not included into the LV8968BB to save cost. If under-voltage operation of the motor is desired either an external charge pump must be inserted between VS and VGIN, or it is possible to use the device in logic level mode by setting MRCONF0[1]. In the latter case logic level FETs must be used for the inverter stage.

System Power Supplies

Three power supplies are integrated into the LV8968BB, all are supplied by VS:

- An internal 3.3 V regulator which provides power to the digital and interface section

- A linear regulator to provide 5 V or 3.3 V for external loads such as a microcontroller
- The VG regulator for the gate voltages of the inverter stage

Internal Regulator (V3RO, V3RI)

The internal regulator provides 3.3 V at V3RO and takes its feedback from V3RI. V3RO and V3RI need to be connected externally and bypassed to GND for stability. This regulator may be used for pullup resistors on the open drain outputs, but the load should not exceeding 1 mA.

LDO 3.3 / 5 V (VCC)

VCC becomes active during Standby mode and can be configured via registers to provide 5 V or 3.3 V. VMCRES low is asserted if the output voltage drops below the threshold levels. VCC may power external loads up to 50 mA (max) and must be bypassed to GND with an external capacitor. The voltage level is programmed in register VCVSEL with OTP backup.

Gate Voltage Regulator (VGIN, VG)

The gate voltage regulator is supplied by VGIN and regulates to either 11 V (typ) or 6 V (typ) at VG. The voltage level is programmed in register VGVSEL with OTP backup.

VG provides the drive voltage for the low-side drivers GL[1-3] directly and for the high side drivers BS[1-3] through the bootstrap circuitry. The output is current limited to 40 mA(min). The output at VG should be bypassed with a capacitor C_{VG} to GND which should be at least 20 times the maximum gate charge of the power FETs.

Motor Control Inputs

Once the LV8968BB is in standby mode with the supplies running, a microcontroller can facilitate motor control via the inputs EN, IL[1-3], IH[1-3]. All are VS compatible. Additionally, PWMIN a supply level compatible level shifter can bring a high voltage control such as a PWM signal or a crash indicator to microcontroller supply level.

PWM Interface (PWMIN, RXD)

The PWM interface translates a VS level signal with a threshold of 50%(typ) VS to a digital signal appearing at RXD. This signal can be used for input PWM translation or for CRASH signal communication from outside the application to the microcontroller.

Drive Enable (EN)

Taking EN high enables the output drivers GH[1-3] and GL[1-3] for control by the microcontroller, taking EN low disables them by switching all of them to the sources of the corresponding external FETs. In addition, a high on EN will override a low on WAKE allowing the microcontroller to keep the motor running even after the WAKE line has gone low.

LV8968BBUW

Motor Control (IL[1-3] IH[1-3])

The individual motor phases are controlled by inputs IL[1-3] and IH[1-3]. IH[1-3] are active high, while IL[1-3] are active low allowing for parallel control with only three PWM outputs using internal dead time. To control the driver stage with GH [1-3] and GL[1-3] EN has to be “high”. The LV8968BB will insert an adjustable dead time during output transitions to prevent short circuiting the FETs. Two drive modes exist:

Drive 6 Mode

In drive 6 mode, each input independently controls its corresponding output requiring 6 independent PWM channels in the microcontroller. A “high” on IH1 will result in a “high” on GH1. A “high” on IL1 will result in a “low” on GL1, and so forth. Trying to force a short by driving IH1 high and IL1 low will be ignored by the logic of the LV8968BB.

Table 5. DRIVE 6 MODE

| Input | | Output | |
|---------|---------|---------|---------|
| IH[1-3] | IL[1-3] | GH[1-3] | GL[1-3] |
| L | L | L | H |
| L | H | L | L |
| H | L | L | L |
| H | H | H | L |

Drive 3 Mode

This mode is suitable for small microcontrollers which do not have 6 dedicated PWM control lines. IL[1-3] serve as enable signals for the phase drivers GH[1-3] and GL[1-3]

while IH[1- 3] serve as their PWM inputs. Connect the microcontroller’s PWM line to IH[1-3] and the phase select lines to the individual IL inputs 1-3 respectively.

Table 6. DRIVE 3 MODE

| Input | | Output | |
|---------|---------|---------|---------|
| IH[1-3] | IL[1-3] | GH[1-3] | GL[1-3] |
| L | L | L | L |
| L | H | L | H |
| H | L | L | L |
| H | H | H | L |

Gate Drive

The gate drive circuit of the LV8968BB includes 3 half-bridge drivers which control six external N-Channel FETs. The high side gate drivers GH[1-3] switch their gate connection either to corresponding BS[1-3] pin or the respective phase connection SH[1-3]. The low-side gate drivers GL[1-3] are switched from VG to the corresponding source connection SL[1-3]. Both high and low side switches are hard switching, but saturate around 400 mA (typ) for pullup/down currents. Slope control has to be implemented with gate resistors.

“Through Current Prevention Function”

Current shoot-through protection of the bridge-drivers is implemented by ignoring inputs at IH[n] and IL[n] that would result in turning on of both high-and low-side FET at the same time. In addition a dead-time counter is

implemented that begins counting after one driver has been turned off, and blocks the turning-on of the complementary driver for a programmable time t_{FDTI} from (typ) $200 \text{ ns} < t_{FDTI} < 3.2 \mu\text{s}$ (typ).

Dead-time Counter

The dead-time counter uses a fixed minimum dead-time which can be programmed into 4bit parameter FDTILIM. The dead-time is never allowed to fall below that value. A dynamic dead time register FDTI allows dead time variation during motor operation. This register is uploaded at the beginning of every dead time measurement. Flag FDTIBSY is high when a dead time value has been written to register FDTI but was not uploaded to the counter, yet. Two consecutive writes to FDTI before a counter upload are flagged as an SPI error by setting bit SACF in the SPI status register GSDAT.

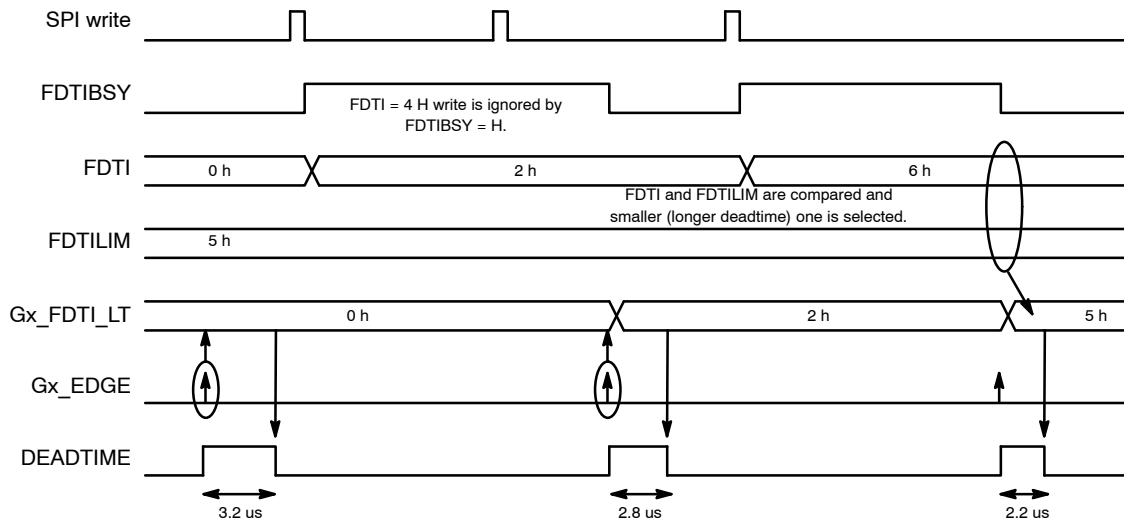

Figure 6. Dead Time Programming

Short Protection

To protect against FET shorts the drain–source voltage of the active external power FETs is monitored. The drain source voltage of the high side FETs is monitored between VDH and the corresponding source SH[1–3]. While the low side FETs are monitored between SH[1–3] and SL[1–3]. After activation of the FET the short detection is masked for time t_{FSFT} to allow for signal settling. If after the masking time t_{FSFT} the FET voltage exceeding V_{FSDL} continues for t_{FSDT} , a FET short error is flagged. For details see “System Errors and Warnings” on page 18.

4 bit register FSDL selects the short–circuit shutoff voltage between $1.6\text{ V} > V_{FSLD} > 100\text{ mV}(\text{typ})$. The masking time can be between $0.8\text{ }\mu\text{s} < t_{FSF} < 3.2\text{ }\mu\text{s}(\text{typ})$ as defined by register FSFT, and the debounce time is between $3.2\text{ }\mu\text{s} < t_{FSDT} < 12.8\text{ }\mu\text{s}(\text{typ})$ as selected by FSDT. These registers are dynamic and FSDL can be changed during motor operation, though FSFT and FSDT can be changed at $\text{EN} = \text{L}$.

Current Sensing and Over–current Shutoff

Single shunt current sensing can be implemented with the integrated high speed sense amplifier. It amplifies the voltage across ISP – ISN with a programmable gain defined by register CSGAIN to be 7.5, 15, 22.5 or 30. Access to this register is dynamic, allowing gain adjustment during motor

operation. The offset is determined by CSOFEN relative to an internal reference which can be either 200 mV(typ) for single ended sensing, or 1.5 V(typ) for sensing current in both directions. The output of the current sense amplifier appears on ISO with a full scale range of 3 V.

Over–current Shutoff

A parallel path implements fast over–current shutoff of the driver stage. Over–current shutoff is triggered if the voltage across ISP – ISN exceeds a programmable level of 100, 150 or 200 mV(typ) – as defined by register OCDL. In over–current shutoff all gate drivers go to Hi–Z, turning the power FETs high–impedance and letting the motor freewheel – this reaction is maskable. For more information on masking and recovery see section “System Errors and Warnings” on page 18.

To suppress switching transients from causing an over–current masking time $0.2\text{ }\mu\text{s} < t_{OCMASK} < 3.2\text{ }\mu\text{s}$ can be programmed into register OCMASK.

Temperature Sensing

The LV8968BB monitors internal junction temperature T_j . The voltage representing this temperature (V_{PTAT}) can be sampled at AOUT as described below. Thermal warnings and errors are issued if T_j exceeds the levels defined by THTSEL:

Table 7. THERMAL THRESHOLDS

| THTSEL | Thermal Warning | Thermal Shutoff |
|--------|-----------------|-----------------|
| 0 | 125°C | 150°C |
| 1 | 150°C | 175°C |

If thermal error shutoff is activated, VG and VCC turn off, and the driver stage goes high impedance. As a result VMCRES goes low and SPI communication is disabled as well. The exact failure modes and masks are described in section “System Errors and Warnings”.

Back EMF and other Measurements

The LV8968BB includes a multiplexer for measuring the phase voltages, the motor voltage and the IC temperature. Depending on the state of AOUTSEL the following voltages appear on AOUT:

Table 8. AOUT SELECTION

| MRAOSEL[2:0] | Pin | Formula | Comment |
|--------------|-----|--|-------------------------------|
| 0 | VDH | $V_{VDH} = 32 V_{AOUT}$ | Motor Supply Voltage |
| 1 | SH1 | $V_{SH1} = 16 V_{AOUT}$ | Phase Voltage 1 |
| 2 | SH2 | $V_{SH2} = 16 V_{AOUT}$ | Phase Voltage 2 |
| 3 | SH3 | $V_{SH2} = 16 V_{AOUT}$ | Phase Voltage 3 |
| 4, 5 | - | $T_J = (V_{AOUT} - 995.7 \text{ mV}) / 2 \text{ mV } ^\circ\text{C}$ | Internal junction temperature |
| 6, 7 | - | High Impedance | |

Watchdog

The LV8968BB includes a window watchdog to monitor the microcontroller. The size of the watchdog window is defined by register WDTWT. For detailed timing information see Figure 7: Window Watchdog Timing. A write access to register MRRST during open window time resets the watchdog timer and it starts counting again. The watchdog will issue an error whenever MRRST is written to

during closed window time or the watchdog time expires. Watchdog error effects can be customized. For detailed error behavior a masking see section “System Errors and Warnings”.

After a watchdog induced microcontroller reset, the error register contents of registers MRDIAG[0] remain conserved until an SPI read access. This helps the microcontroller identify the fault condition.

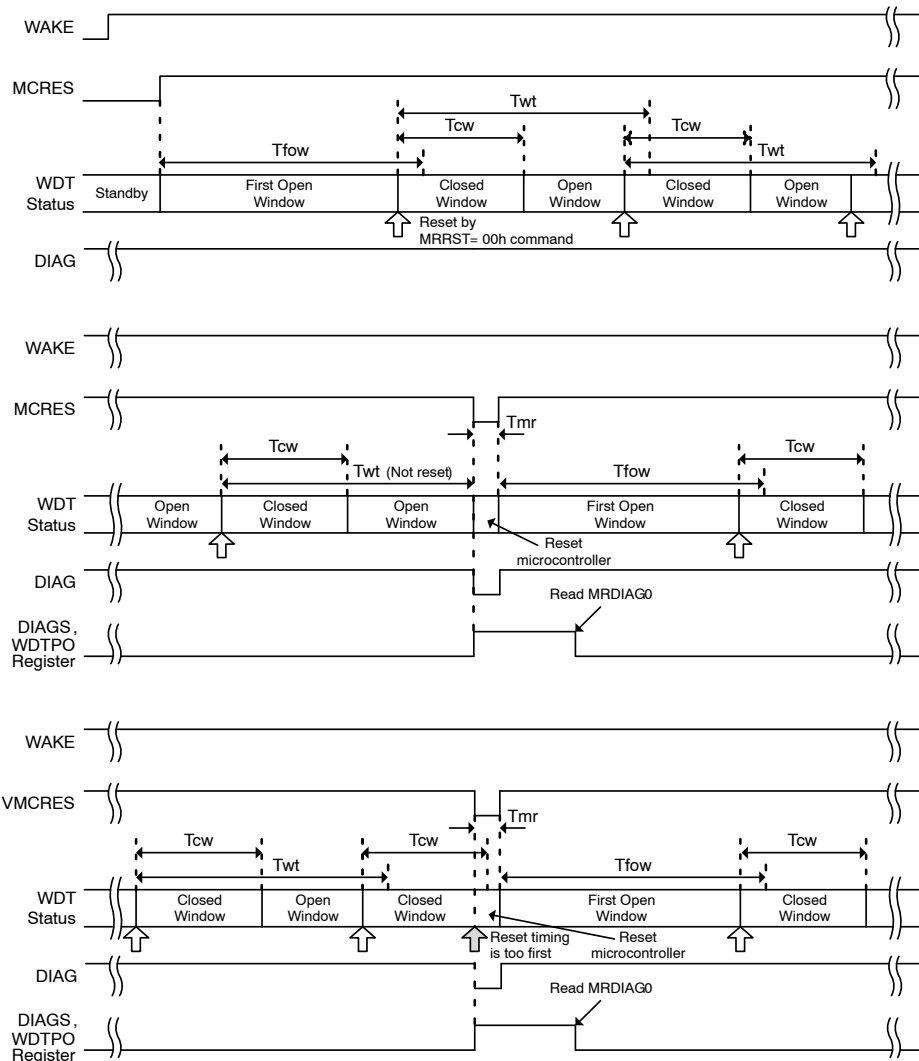

Figure 7. Window Watchdog Timing

Table 9. WINDOW WATCHDOG TIMING OPTIONS ($T_J = -40$ to 150 °C, $V_S = 4.5$ to 40 V)

| Symbol | Characteristic | Min | Typ | Max | Unit |
|-----------|--------------------------------|-------|-------------|-------|---------|
| T_{FOW} | WDT first open window time | | | | ms |
| | WDTWT[2:0] = 0h | 390.0 | 409.6 | 431.2 | |
| | WDTWT[2:0] = 1h | 195.0 | 204.8 | 215.6 | |
| | : (1/2 step) | : | :(1/2 step) | : | |
| T_{CW} | WDT closed window time | | | | ms |
| | WDTWT[2:0] = 0h | 97.4 | 102.4 | 107.8 | |
| | WDTWT[2:0] = 1h | 48.7 | 51.2 | 53.9 | |
| | : (1/2 step) | : | :(1/2 step) | : | |
| T_{WT} | WDT window time | | | | ms |
| | WDTWT[2:0] = 0h | 195.0 | 204.8 | 215.6 | |
| | WDTWT[2:0] = 1h | 97.4 | 102.4 | 107.8 | |
| | : (1/2 step) | : | :(1/2 step) | : | |
| T_{MR} | WDT microcontroller reset time | | | | μ s |
| | WDTWT[2:0] = 0h | 333 | 400 | 422 | |
| | WDTWT[2:0] = 1h | | | | |
| | : (1/2 step) | | | | |

System Errors and Warnings

System errors and warnings are always flagged in their corresponding register MRDIAG0 and MRDIAG1 and their presence is indicated in SPI status register GSDAT. The LV8968BB gives great flexibility in modifying the error response. Error response definition can be backed up into OTP.

All system errors and warnings can cause a transition on DIAG. The polarity of this transition is selected in bit DIAGPOL. DIAG should be connected to an interrupt input of the microcontroller. Errors that can cause serious damage such as short-circuit and over-current may be latched by enabling the corresponding latch bit in MRCONF7. In this

case the LV8968BB will keep the output stage disabled until the latch is cleared by one of the following actions:

- Power on reset
- EN low
- SPI write of FFh to MRRST

Table 10 explains the error behaviour. "Error" names the type of error that is covered. "Reaction Settings Option" lists which options exists for this error and the corresponding register. "Reaction names what happens if the error occurs. Some reactions depend on the "Setting Options" and are described in Notes below.

Table 10. SYSTEM ERROR AND WARNING RESPONSE MATRIX

| Error | Reaction Setting Options | | | | | Reaction | | | | Recovery Condition | Protection Enabled |
|-------------------|--------------------------|------------|----------------|--------------|-----------|----------|----------|-----|--------|----------------------|-------------------------|
| | Setup Register | Mask Error | Report on DIAG | Auto Recover | Latch Off | VG | DRV | VCC | MC RES | | |
| VS Under Voltage | VSUVPS [1:0] | Yes | Yes | Yes | No | ON | (Note 5) | ON | H | VS voltage recovers | After OTP download |
| VS Over Voltage | VSOVPS [1:0] | Yes | Yes | Yes | No | ON | (Note 5) | ON | H | VS voltage recovers | After OTP download |
| VDH Over Voltage | VDOVPS [1:0] | Yes | Yes | Yes | No | ON | (Note 5) | ON | H | VDH voltage recovers | After OTP download |
| VG Under Voltage | VGUVPS [1:0] | Yes | Yes | Yes | No | ON | (Note 5) | ON | H | VG voltage recovers | After VG start-up time |
| VCC Under Voltage | - | No | No | Yes | No | ON | OFF | ON | L | VCC voltage recovers | After VCC start-up time |

Table 10. SYSTEM ERROR AND WARNING RESPONSE MATRIX

| Error | Reaction Setting Options | | | | | Reaction | | | | Recovery Condition | Protection Enabled |
|-------------------|--------------------------|------------|----------------|--------------|-----------|----------|----------|----------|----------|---|----------------------|
| | Setup Register | Mask Error | Report on DIAG | Auto Recover | Latch Off | VG | DRV | VCC | MC RES | | |
| Over Current | OCPS [1:0] | Yes | Yes | Yes | Yes | ON | (Note 5) | ON | H | [Latch Off] EN = L or execute MRRST = Ffh command [Auto Recover] EN = L or after ecovery time [Report] EN = L or motor current is down | EN = H (Normal mode) |
| FET Short | FSPS [1:0] | Yes | Yes | Yes | Yes | ON | (Note 5) | ON | H | [Latch Off] EN = L or execute MRRST = FFh command [Auto Recover] EN = L or after recovery time [Report] EN = L or FET short current is down | EN = H (Normal mode) |
| Thermal Warning | THWPS | Yes | Yes | No | No | ON | ON | ON | H | Temperature is down | After OTP download |
| Thermal Shut Down | THSPS | Yes | No | Yes | No | (Note 6) | (Note 6) | (Note 6) | (Note 7) | Temperature is down | After OTP download |
| Watch Dog Timer | WDTPS | Yes | No | Yes | No | ON | (Note 6) | ON | (Note 8) | After output reset pulse from VMCRESPIN | VMCRESPIN = H |

- 5. Report or Ignore = ON, Latch Off or Auto Recover = OFF
- 6. Ignore = ON, Auto Recover = OFF
- 7. Ignore = H, Auto Recover = L
- 8. Ignore = Fixed H, Auto Recover = Output L pulse

SPI Interface

In the LV8968BB the SPI Interface is used to perform general communications for status reporting, control and programming.

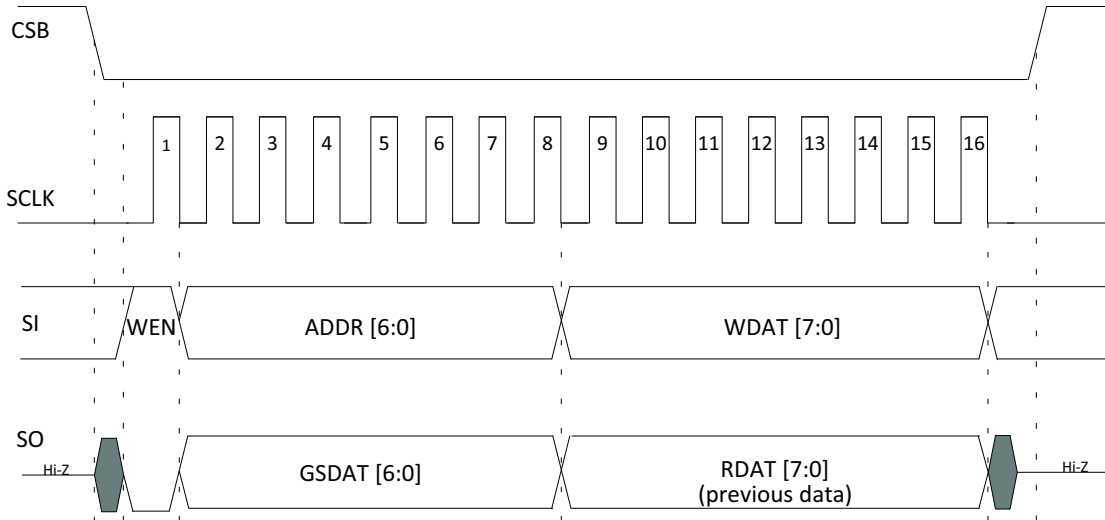

Figure 8. SPI Format in Write Mode

LV8968BBUW

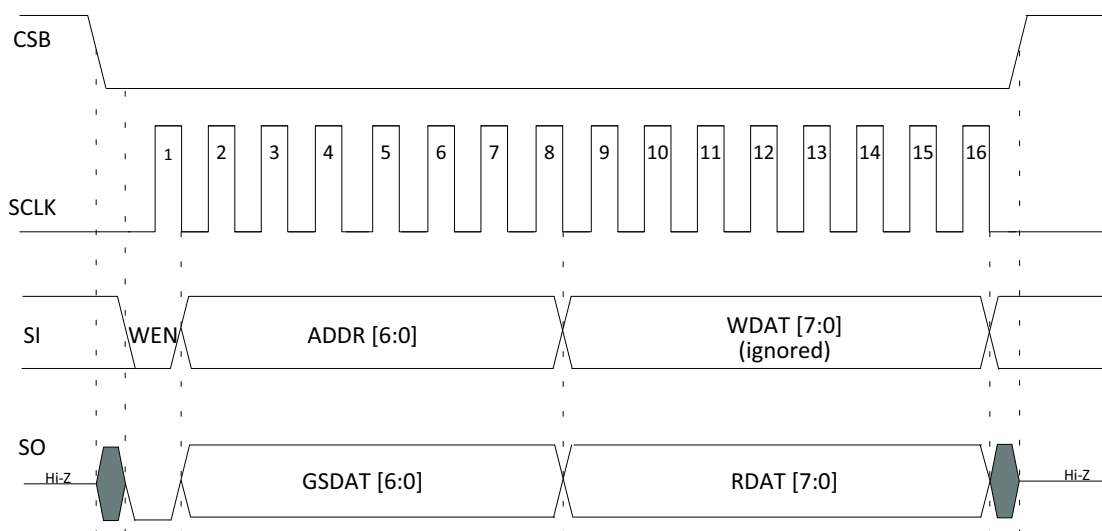

Figure 9. SPI Format in Read Mode

SPI communications with the LV8968BB follows established industry standard practices including the use of WEN and start and stop bits as shown above. Data is transferred MSB first and both clock and data are transferred as 'true' data with the higher level indicating a logical 1 or true state.

There are two items to be especially careful of with the general communication scheme:

- Communications must be full duplex and simultaneous. It is not allowed to send one transaction and then read data on a second transaction as the status register information will be updated on the first transaction and then be out of date for the second. Some systems break transactions into separate read and write operations which is not acceptable

- It is important the system master have the clock and data polarities and phases as shown above. Both the clock and data on some systems can be inverted for various reasons but must arrive at the LV8968BB per the above drawing. Common errors include SCLK inversion such that the leading edge arrives as a downward transition rather than a rising edge, or having the data to clock phase incorrect. Data phase must be such that the data only changes during a clock falling edge and is completely stable during a clock rising edge. This means a good margin of one half a bit time exists to eliminate transmission delay hazards.

The first byte returned on all transactions is always the status register GSDAT, and contains information such as the busy flag during programming operations

Table 11.

| GSDAT[7:0] | | | | | | | | |
|------------|-------|------|-------|-------|------|-----------|-------|--------------------------------|
| Bit 7 | 6 | 5 | 4 | 3 | 2 | 1 | Bit 0 | |
| 0 | ORBEN | SACF | DIAGS | LATCH | OBSY | SMOD[1:0] | | |
| NA | NA | NA | NA | NA | NA | NA | NA | Sleep mode |
| NA | NA | NA | NA | NA | NA | 0 | 1 | Device start up time |
| NA | NA | NA | NA | NA | NA | 1 | 0 | Standby mode |
| NA | NA | NA | NA | NA | NA | 1 | 1 | Normal mode |
| NA | 0 | 0 | 0 | 0 | 0 | NA | NA | Normal Operation |
| NA | NA | NA | NA | NA | 1 | NA | NA | OTP download of default values |
| NA | NA | NA | NA | 1 | NA | NA | NA | Latched shutdown condition |
| NA | NA | NA | 1 | NA | NA | NA | NA | Failure Condition |
| NA | NA | 1 | NA | NA | NA | NA | NA | Last SPI access failed* |
| NA | 1 | NA | NA | NA | NA | NA | NA | OTP integrity test mode |

LV8968BBUW

The following SPI failures are detectable and reported collectively by a high on SACF in GSDAT[5] as general SPI failures:

- ◆ Any access to an address which is not assigned.
- ◆ The number of SCLK edges is not 16 within one word transfer
- ◆ Any access to MRCONF and ORCONF while OBSY = 1, (During write operations)
- ◆ Write access to MRODL register while OBSY = 1, (during write operations)
- ◆ Write access to any of the main registers after setting MSAENB = 1 (Implies Reg. address 04 h to 07 h are locked)
- ◆ Write access to any of the OTP registers after OSAENB = 1 (Implies Reg. address 40 h to 43 h are locked)
- ◆ Write access attempt to a read only or locked register
- ◆ SI signal changed at positive edge of SCLK (Incorrect data/sclk phase setup)
- ◆ Write access to dead-time register FDTI while FDTIBSY is still high (last value has not been uploaded)

SPI Timing

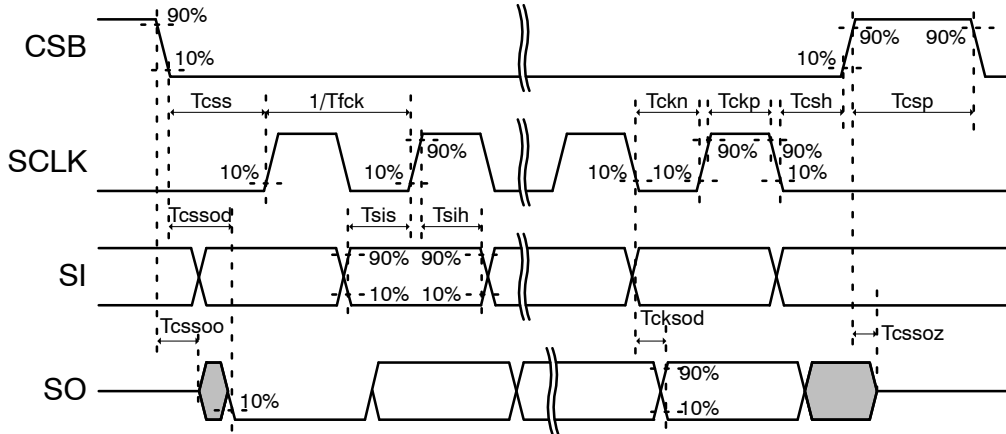

Figure 10. SPI Timing Diagram

Table 12. SPI TIMING (T_J = -40 to 150°C, V_S = 4.5 to 40 V, SO load = 50 pF)

| Symbol | Comment | Min | Typ | Max | Unit |
|--------------------|-----------------------------------|-----|-----|-----|------|
| T _{FCK} | SCLK Clock Frequency | | | 4.5 | MHz |
| T _{CKP} | SCLK High Pulse Width | 90 | | | ns |
| T _{CKN} | SCLK Low Pulse Width | 90 | | | ns |
| T _{CSS} | CSB Setup Time | 90 | | | ns |
| T _{CSH} | CSB Hold Time | 0 | | | ns |
| T _{CSP} | CSB High Pulse Width | 90 | | | ns |
| T _{SIS} | SI Setup Time | 45 | | | ns |
| T _{SIH} | SI Hold Time | 45 | | | ns |
| T _{CKSOD} | SCLK Fall Edge to SO Delay Time | | | 75 | ns |
| T _{CSSOD} | CSB Fall Edge to SO Delay Time | | | 75 | ns |
| T _{CSSOO} | CSB Fall Edge to SO Data Out Time | 0 | | | ns |
| T _{CSSOZ} | CSB Rise Edge to SO Hi-Z Out Time | | | 75 | ns |

NOTE: SPI-Interface can be used after the data download of the OTP has been completed. However it can not be used during VMCRE = L.

OTP Programming

The OTP register data is typically transferred into the main registers at device startup (From sleep to standby

transition). This operation takes up to 125 μs. A high OBSY flag in the first returned byte during a SPI transaction indicates this.

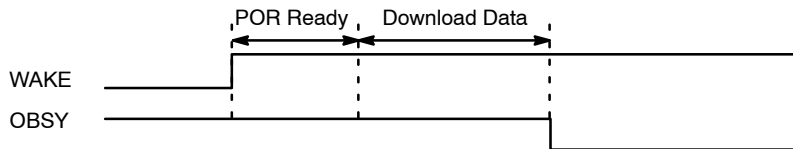

Figure 11. OTP Data Download Timing at Startup

An OTP download can also actively be initiated by writing 00h to register MRODL. This command requires monitoring the OBSY flag. Don't perform specific register

access (MRCONF0 ~ 3, ORCONF0 ~ 3, MRORB, MRODL) until the OBSY flag is cleared.

LV8968BBUW

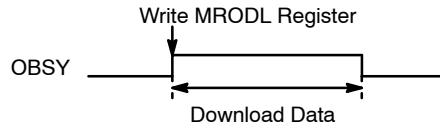

Figure 12. OTP Data Download Timing after an MRODL Command

OTP Programming Overall

Figure 13 shows overall of the OTP memory write and verify flow. It consists of preparation, write and three times of data integrity verification.

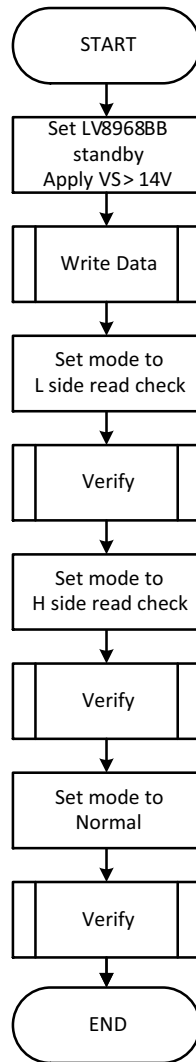

Figure 13. OTP Memory Write and Verify Flow

OTP Programming

The OTP registers can be programmed in Standby mode only while the write lock bit OSAENB is set 0. And, the supply voltage at pin VS must be more than 14 V. The actual write operation to the OTP memory will be done, when the state change from 0 to 1 is commanded. Once the bit state is changed to 1, it cannot be change back to 0. The number of writing is limited to one per bit.

The OBSY flag will be reset at the end of the write cycle. OBSY is in GSDAT register. To get GSDAT, SPI accesses to the register MRACK is recommended. MRACK doesn't interfere with the programming operation.

MRCONF0 ~ 3, ORCONF0 ~ 3, MRORB, MRODL registers cannot be accessed during an OTP write cycle.

LV8968BBUW

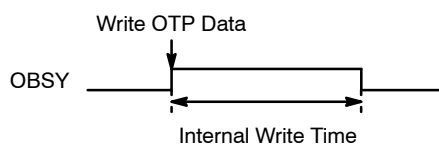

Figure 14. OTP Programming Timing

The programming takes 4 ms maximum. To simplify operation, a waiting for 4 ms plus margin can be applicable instead of a polling of the flag OBSY. (Figure 15)

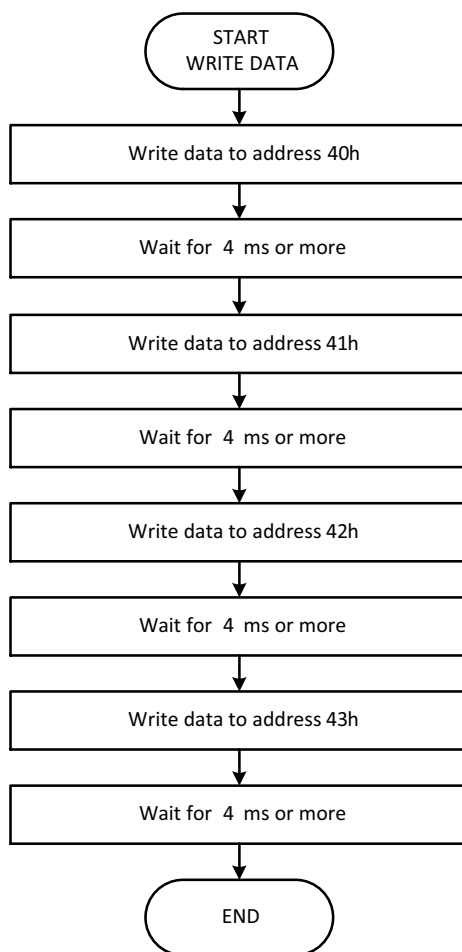

Figure 15. OTP Memory Write and Verify Flow

OTP Data Integrity Verification

In order to verify that the OTP programming operation was successful. It is strongly recommended to do an OTP margin check: To do this, the OTP registers are downloaded into the main register bank with minimum and maximum readout thresholds. This OTP download is forced by writing 00h to register MRODL. The readout threshold is set in register MRORB.

OTP Margin read check sequence after programmed:

1. Set OTP readout threshold “low” by setting ORBEN = 1 and ORBLV = 0 in register MRORB
2. Execute OTP download command by writing 00h to MRODL
3. Verify that the main register contents are consistent with the programmed OTP data
4. Set OTP readout threshold “high” by setting ORBEN = 1 and ORBLV = 1 in register MRORB
5. Execute OTP download command by writing 00h to MRODL
6. Verify that the main register contents are consistent with the programmed OTP data
7. Return OTP threshold to normal by setting ORBEN = 0 and ORBLV = 0
8. Execute OTP download command
9. Verify that the main register contents are consistent with the programmed OTP data

Locking OTP Register Contents

MSAENB bit and OSAENB bit are used in order to prevent write-access of main- and OTP registers respectively.

CAUTION: Inadvertent writing of these bits will permanently lock the corresponding register blocks from any further write access. Should only be set at end of development cycles.

Table 13. REGISTER MAP

| WENB | WTIM | ADDR [6:0] | Data Name | D[7] | D[6] | D[5] | D[4] | D[3] | D[2] | D[1] | D[0] | |
|-----------------|-----------|------------|-----------|---|------------|-------------|--------|--------------|---------------------------|-------------|--------|---------|
| Always NG | Always NG | - | GSDAT | 0 | ORBEN | SACF | DIAGS | LATCH | OBSY | SMOD[1:0] | | |
| OSAENB (Note 9) | EN=L | 00h | MRCONF0 | 0 | 0 | THTSEL | DFCSEL | DIAGLTO | DIAGPOL | VGVSSEL | VCVSEL | |
| | | 01h | MRCONF1 | 0 | 0 | 0 | WDTPS | THSPS | THWPS | VGUVPS[1:0] | | |
| | | 02h | MRCONF2 | 0 | 0 | VDOVPS[1:0] | | VSOVPS[1:0] | | VSUVPS[1:0] | | |
| Read Only | Read Only | 03h | MRCONF3 | 0 | 0 | 0 | 0 | 0 | 0 | 0 | OSAENB | |
| MSAENB (Note 9) | EN=L | 04h | MRCONF4 | 0 | WDTWT[2:0] | | 0 | CSOFEN | AWODLEN | D3MDEN | | |
| | | 05h | MRCONF5 | 0 | 0 | OCDL[1:0] | | OCMASK[3:0] | | | | |
| | | 06h | MRCONF6 | 0 | 0 | 0 | 0 | FSFT[1:0] | | FSDT[1:0] | | |
| | | 07h | MRCONF7 | FSPS[1:0] | | OCPS[1:0] | | FDTILIM[3:0] | | | | |
| Always OK | | 08h | MRCONF8 | 0 | 0 | 0 | 0 | 0 | 0 | 0 | MSAENB | |
| Always OK | Always OK | 10h | MRAOSEL | 0 | 0 | 0 | 0 | 0 | AOUTSEL[2:0] (Default=7h) | | | |
| | | 11h | MRCSEG | 0 | 0 | 0 | 0 | 0 | 0 | CSGAIN[1:0] | | |
| | | 12h | MRFSDL | 0 | 0 | 0 | 0 | FSDL[3:0] | | | | |
| | | 13h | MRFDTI | 0 | 0 | 0 | 0 | FDTI[3:0] | | | | |
| | | 14h | MRFDTIF | 0 | 0 | 0 | 0 | 0 | 0 | 0 | 0 | FDTIBSY |
| | | 15h | MRRST | Write 00h: Reset WDT / Write FFh: Reset latch off | | | | | | | | |
| | EN=L | 16h | MRORB | 0 | 0 | 0 | 0 | 0 | 0 | ORBEN | ORBLV | |
| | | 17h | MRODL | Write 00h: Execute OTP data download | | | | | | | | |
| Read Only | Read Only | 20h | MRDIAG0 | 0 | 0 | 0 | WDTP0 | THSPO | THWPO | FSPO | OCPO | |
| | | 21h | MRDIAG1 | 0 | 0 | 0 | VCUVPO | VGUVPO | VDOVPO | VSOVPO | VSUVPO | |
| | | 22h | MRACK | 0 | 1 | 0 | 1 | 0 | 1 | 0 | 1 | |
| OSAENB (Note 9) | EN=L | 40h | ORCONF0 | ORCONF0[7:6] | | THTSEL | DFCSEL | DIAGLTO | DIAGPOL | VGVSSEL | VCVSEL | |
| | | 41h | ORCONF1 | ORCONF1[7:5] | | | WDTPS | THSPS | THWPS | VGUVPS[1:0] | | |
| | | 42h | ORCONF2 | ORCONF2[7:6] | | VDOVPS[1:0] | | VSOVPS[1:0] | | VSUVPS[1:0] | | |
| | | 43h | ORCONF3 | ORCONF3[7:1] | | | | | | | | OSAENB |

NOTE: SPI access to addresses not listed here will result in an SPI access failure error (SACF).

9. At Test mode, ENB = 1 setting is ignored.

MRCONF0 (Default: 00h)

(Write Access Only when EN = Low. OTP Backup Possible)

| ADDR | Data Name | D[7] | D[6] | D[5] | D[4] | D[3] | D[2] | D[1] | D[0] |
|------|-----------|------|------|--------|--------|---------|---------|-------|--------|
| 00h | MRCONF0 | 0 | 0 | THTSEL | DFCSEL | DIAGLTO | DIAGPOL | VGSEL | VCVSEL |

THTSEL

Temperature warning threshold and error selection.

- ◆ THTSEL = 0: Thermal warning = 125°C, Thermal shut down = 150°C
- ◆ THTSEL = 1: Thermal warning = 150°C, Thermal shut down = 175°C

DFCSEL

Defines the condition under which the error registers are reset, by error condition removed only, or by error condition removed and subsequent SPI read access of the register in question.

- ◆ DFCSEL = 0: If error was cleared, DIAGS flag of GSDAT and MRDIAG0, 1 flag are reset by MRDIAG0, 1 read
- ◆ DFCSEL = 1: DIAGS flag of GSDAT and MRDIAG0,1 flag are reset by recovery condition

DIAGLTO

If this bit is set, only latched errors result in a transition on DIAG. Otherwise all errors (and warnings) will be flagged.

- ◆ DIAGLTO = 0: At the time of detecting auto recover or latch off error, DIAG output is on
- ◆ DIAGLTO = 1: At the time of detecting latch off error, DIAG output is on

DIAGPOL

Decides the polarity of the DIAG output.

- ◆ DIAGPOL = 0: At the time of detecting diagnostic error, DIAG output is L
- ◆ DIAGPOL = 1: At the time of detecting diagnostic error, DIAG output is H

VGSEL

Selects if the IC is in logic level mode or normal mode which modifies the gate voltage of the drive section.

- ◆ VGSEL = 0: VG normal mode (VG = 11 V)
- ◆ VGSEL = 1: VG logic level mode (VG = 6 V)

VCVSEL

Selects the output voltage of VCC to be either 3.3 V or 5 V. The wrong bit selection has a possibility to damage the microcontroller. Please make sure the appropriate selection.

- ◆ VCVSEL = 0: VCC = 3.3 V
- ◆ VCVSEL = 1: VCC = 5.0 V

MRCONF1 (Default: 00h)

(Write Access Only when EN = Low. OTP Backup Possible)

| ADDR | Data Name | D[7] | D[6] | D[5] | D[4] | D[3] | D[2] | D[1] | D[0] |
|------|-----------|------|------|------|-------|-------|-------|-------------|------|
| 01h | MRCONF1 | 0 | 0 | 0 | WDTPS | THSPS | THWPS | VGUVPS[1:0] | |

WDTPS

Watchdog error results in error response or is ignored.

- ◆ WDTPS = 0: Ignore WDT error
- ◆ WDTPS = 1: Emergency off and report a WDT error (Auto recover)

THSPS

Thermal shutdown error results in error response or is ignored.

- ◆ THSPS = 0: Ignore thermal shut down error
- ◆ THSPS = 1: Emergency off and report at thermal shut down error (Auto recover)

THWPS

- ◆ THWPS = 0: Ignore thermal warning error
- ◆ THWPS = 1: Report thermal warning error

LV8968BBUW

VGUVPS[1:0]

- ◆ VGUVPS[1:0] = 0h: Ignore VG under voltage error
- ◆ VGUVPS[1:0] = 1h: Report VG under voltage error
- ◆ VGUVPS[1:0] = 2h, 3h: Emergency off and report at VG under voltage error (Auto recover)

MRCONF2 (Default: 00h)

(Write Access Only when EN = Low. OTP Backup Possible)

| ADDR | Data Name | D[7] | D[6] | D[5] | D[4] | D[3] | D[2] | D[1] | D[0] |
|------|-----------|------|------|-------------|------|-------------|------|-------------|------|
| 02h | MRCONF2 | 0 | 0 | VDOVPS[1:0] | | VSOVPS[1:0] | | VSUVPS[1:0] | |

VDOVPS[1:0]

- ◆ VDOVPS[1:0] = 0h: Ignore VDH over voltage error
- ◆ VDOVPS[1:0] = 1h: Report VDH over voltage error
- ◆ VDOVPS[1:0] = 2h, 3h: Emergency off and report at VDH over voltage error (Auto recover)

VSOVPS[1:0]

- ◆ VSOVPS[1:0] = 0h: Ignore VS over voltage error
- ◆ VSOVPS[1:0] = 1h: Report VS over voltage error
- ◆ VSOVPS[1:0] = 2h, 3h: Emergency off and report at VS over voltage error (Auto recover)

VSUVPS[1:0]

- ◆ VSUVPS[1:0] = 0h: Ignore VS under voltage error
- ◆ VSUVPS[1:0] = 1h: Report VS under voltage error
- ◆ VSUVPS[1:0] = 2h, 3h: Emergency off and report at VS under voltage error (Auto recover)

MRCONF3 (Default: 00h)

(Read Only)

| ADDR | Data Name | D[7] | D[6] | D[5] | D[4] | D[3] | D[2] | D[1] | D[0] |
|------|-----------|------|------|------|------|------|------|------|--------|
| 03h | MRCONF3 | 0 | 0 | 0 | 0 | 0 | 0 | 0 | OSAENB |

OSAENB

Setting this bit disables all write access to the configuration registers MRCONF0, MRCONF1 and MRCONF2 and the OTP backup register. Set to prevent system parameters from being modified.

- ◆ OSAENB = 0: Enable write access of MRCONF0~2 and ORCONF0~3
- ◆ OSAENB = 1: Disable write access of MRCONF0~2 and ORCONF0~3

MRCONF4 (Default: 00h)

(Write Access Only when EN = Low)

| ADDR | Data Name | D[7] | D[6] | D[5] | D[4] | D[3] | D[2] | D[1] | D[0] |
|------|-----------|------|------------|------|------|------|--------|---------|--------|
| 04h | MRCONF4 | 0 | WDTWT[2:0] | | | 0 | CSOFEN | AWODLEN | D3MDEN |

WDTWT[2:0]

Defines the watchdog timer window sizes.

- ◆ WDTWT[2:0] = 0h: $T_{\text{FOW}} = 409.6 \text{ ms}$, $T_{\text{CW}} = 102.4 \text{ ms}$, $T_{\text{WT}} = 204.8 \text{ ms}$
- ◆ WDTWT[2:0] = 1h: $T_{\text{FOW}} = 204.8 \text{ ms}$, $T_{\text{CW}} = 51.2 \text{ ms}$, $T_{\text{WT}} = 102.4 \text{ ms}$
- :
- : (1/2 step)
- :
- ◆ WDTWT[2:0] = 7h: $T_{\text{FOW}} = 3.2 \text{ ms}$, $T_{\text{CW}} = 0.8 \text{ ms}$, $T_{\text{WT}} = 1.6 \text{ ms}$

CSOFEN

Selects the offset of the current sense amplifier.

- ◆ CSOFEN = 0: Current sense amp offset = 1.5 V
- ◆ CSOFEN = 1: Current sense amp offset = 0.2 V

AWODLEN

Periodical (200 ms) OTP download during EN = H.

- ◆ AWODLEN = 0: Not download OTP data in normal mode
- ◆ AWODLEN = 1: Download OTP data periodically in normal mode

D3MDEN

Chooses how the output drivers are addressed, with six PWM channels, or with three PWM channels and three enables.

- ◆ D3MDEN = 0: Drive 6 mode
- ◆ D3MDEN = 1: Drive 3 mode

MRCONF5 (Default: 00h)

(Write Access Only when EN = Low)

| ADDR | Data Name | D[7] | D[6] | D[5] | D[4] | D[3] | D[2] | D[1] | D[0] |
|------|-----------|------|------|-----------|------|-------------|------|------|------|
| 05h | MRCONF5 | 0 | 0 | OCDL[1:0] | | OCMASK[3:0] | | | |

OCDL[1:0]

Defines the over-current detection threshold voltage between ISN and ISP.

- ◆ OCDL[1:0] = 0h: Over-current detect level = 200 mV
- ◆ OCDL[1:0] = 1h: Over-current detect level = 150 mV
- ◆ OCDL[1:0] = 2h, 3h: Over-current detect level = 100 mV

OCMASK[3:0]

Masking time for the over-current detection after every output transition.

- ◆ OCMASK[3:0] = 0h: Over-current mask time = 0.2 μs
- ◆ OCMASK[3:0] = 1h: Over-current mask time = 0.4 μs
- :
- : (0.2 μs step)
- :
- ◆ OCMASK[3:0] = Eh: Over-current mask time = 3.0 μs
- ◆ OCMASK[3:0] = Fh: Over-current mask time = 3.2 μs

MRCONF6 (Default: 00h)

(Write Access Only when EN = Low)

| ADDR | Data Name | D[7] | D[6] | D[5] | D[4] | D[3] | D[2] | D[1] | D[0] |
|------|-----------|------|------|------|------|-----------|------|-----------|------|
| 06h | MRCONF6 | 0 | 0 | 0 | 0 | FSFT[1:0] | | FSDT[1:0] | |

FSFT[1:0]

External FET short detection debounce time. A short condition has to remain valid during this time.

- ◆ FSFT[1:0] = 0h: FET short detect time = 0.8 μ s
- ◆ FSFT[1:0] = 1h: FET short detect time = 1.6 μ s
- ◆ FSFT[1:0] = 2h: FET short detect time = 2.4 μ s
- ◆ FSFT[1:0] = 3h: FET short detect time = 3.2 μ s

FSDT[1:0]

External FET short circuit detection masking time, starts after turn-on of the FET.

- ◆ FSDT[1:0] = 0h: FET short masking time = 3.2 μ s
- ◆ FSDT[1:0] = 1h: FET short masking time = 6.4 μ s
- ◆ FSDT[1:0] = 2h: FET short masking time = 9.6 μ s
- ◆ FSDT[1:0] = 3h: FET short masking time = 12.8 μ s

MRCONF7 (Default: 00h)

(Write Access Only when EN = Low)

| ADDR | Data Name | D[7] | D[6] | D[5] | D[4] | D[3] | D[2] | D[1] | D[0] |
|------|-----------|-----------|------|-----------|------|--------------|------|------|------|
| 07h | MRCONF7 | FSPS[1:0] | | OCPS[1:0] | | FDTILIM[3:0] | | | |

FSPS[1:0]

Short circuit error decision mask.

- ◆ FSPS[1:0] = 0h: Ignore FET short error
- ◆ FSPS[1:0] = 1h: Report FET short error
- ◆ FSPS[1:0] = 2h: Emergency off and report at FET short error (Auto recover)
- ◆ FSPS[1:0] = 3h: Emergency off and report at FET short error (Latched off)

OCPS[1:0]

Over-current error decision mask.

- ◆ OCPS[1:0] = 0h: Ignore over-current error
- ◆ OCPS[1:0] = 1h: Report over-current error
- ◆ OCPS[1:0] = 2h: Emergency off and report at over-current error (Auto recover)
- ◆ OCPS[1:0] = 3h: Emergency off and report at over-current error (Latched off)

FDTILIM[3:0]

Minimum Dead time programming register.

- ◆ FDTILIM[3:0] = 0h: FET dead time = 3.2 μ s
- ◆ FDTILIM[3:0] = 1h: FET dead time = 3.0 μ s
- ◆ :
- ◆ : (-0.2 μ s step)
- ◆ :
- ◆ FDTILIM[3:0] = Eh: FET dead time = 0.4 μ s
- ◆ FDTILIM[3:0] = Fh: FET dead time = 0.2 μ s

MRCONF8 (Default: 00h)

(Write access only when EN = Low)

| ADDR | Data Name | D[7] | D[6] | D[5] | D[4] | D[3] | D[2] | D[1] | D[0] |
|------|-----------|------|------|------|------|------|------|------|--------|
| 08h | MRCONF8 | 0 | 0 | 0 | 0 | 0 | 0 | 0 | MSAENB |

MSAENB

Setting this bit disables all write access to the configuration registers MRCONF4 to MRCONF7.

- ◆ MSAENB = 0: Enable write access of MRCONF4 ~ 7
- ◆ MSAENB = 1: Disable write access of MRCONF4 ~ 7

MRAOSEL (Default: 07h)

(Full Dynamic Access)

| ADDR | Data Name | D[7] | D[6] | D[5] | D[4] | D[3] | D[2] | D[1] | D[0] |
|------|-----------|------|------|------|------|------|--------------|------|------|
| 10h | MRAOSEL | 0 | 0 | 0 | 0 | 0 | AOUTSEL[2:0] | | |

AOUTSEL[2:0]

Select the internal nodes brought out on AOUT.

- ◆ AOUTSEL[2:0] = 0h: AOUT = Output VDH voltage level
- ◆ AOUTSEL[2:0] = 1h: AOUT = Output SH1 voltage level
- ◆ AOUTSEL[2:0] = 2h: AOUT = Output SH2 voltage level
- ◆ AOUTSEL[2:0] = 3h: AOUT = Output SH3 voltage level
- ◆ AOUTSEL[2:0] = 4h, 5h: AOUT = Output thermal monitor voltage level
- ◆ AOUTSEL[2:0] = 6h, 7h: AOUT = Hi-Z

MRCSG (Default: 00h)

(Full Dynamic Access)

| ADDR | Data Name | D[7] | D[6] | D[5] | D[4] | D[3] | D[2] | D[1] | D[0] |
|------|-----------|------|------|------|------|------|------|-------------|------|
| 11h | MRCSG | 0 | 0 | 0 | 0 | 0 | 0 | CSGAIN[1:0] | |

CSGAIN[1:0]

Programs the gain of the current sense amplifier.

- ◆ CSGAIN[1:0] = 0h: Current sense amp gain = 7.5
- ◆ CSGAIN[1:0] = 1h: Current sense amp gain = 15
- ◆ CSGAIN[1:0] = 2h: Current sense amp gain = 22.5
- ◆ CSGAIN[1:0] = 3h: Current sense amp gain = 30

MRFSDL (Default: 00h)

(Full Dynamic Access)

| ADDR | Data Name | D[7] | D[6] | D[5] | D[4] | D[3] | D[2] | D[1] | D[0] |
|------|-----------|------|------|------|------|-----------|------|------|------|
| 12h | MRFSDL | 0 | 0 | 0 | 0 | FSDL[3:0] | | | |

FSDL[3:0]

Defines the maximum allowable drain source voltage across a power FET.

- ◆ FSDL[3:0] = 0h: FET short detect level = 100 mV
- ◆ FSDL[3:0] = 1h: FET short detect level = 200 mV
- ◆ :
- ◆ : (100 mV step)
- ◆ :
- ◆ FSDL[3:0] = Eh: FET short detect level = 1500 mV
- ◆ FSDL[3:0] = Fh: FET short detect level = 1600 mV

MRFDTI (Default: 00h)

(Full Dynamic Access)

| ADDR | Data Name | D[7] | D[6] | D[5] | D[4] | D[3] | D[2] | D[1] | D[0] |
|------|-----------|------|------|------|------|-----------|------|------|------|
| 13h | MRFDTI | 0 | 0 | 0 | 0 | FDTI[3:0] | | | |

FDTI[3:0]

Dead time programming register. This dead time will be applied unless it is smaller than FDTILIM[3:0] in MRCONF7.

- ◆ FDTI[3:0] = 0h: FET dead time = 3.2 μ s
- ◆ FDTI[3:0] = 1h: FET dead time = 3.0 μ s
- :
- : (-0.2 μ s step)
- :
- ◆ FDTI[3:0] = Eh: FET dead time = 0.4 μ s
- ◆ FDTI[3:0] = Fh: FET dead time = 0.2 μ s

MRFDTIF (Default: 00h)

(Full Dynamic Access)

| ADDR | Data Name | D[7] | D[6] | D[5] | D[4] | D[3] | D[2] | D[1] | D[0] |
|------|-----------|------|------|------|------|------|------|------|---------|
| 14h | MRFDTIF | 0 | 0 | 0 | 0 | 0 | 0 | 0 | FDTIBSY |

FDTIBSY

FDTIBSY goes high after the dead-time register was written to via SPI but not uploaded into the dead-time counter. Upload happens at the beginning of every dead time measuring period (falling edge of a gate signal) and clears the FDTIBSY flag.

A write access MRFDTIF = 01h also clears the FDTIBSY flag.

MRRST

(Full Dynamic Access)

| ADDR | Data Name | D[7] | D[6] | D[5] | D[4] | D[3] | D[2] | D[1] | D[0] |
|------|-----------|---|------|------|------|------|------|------|------|
| 15h | MRRST | Write 00h: Reset WDT / Write FFh: Reset latch off | | | | | | | |

MRRST[7:0]

Write access to this register resets the Watchdog or the Error latch.

- ◆ Write MRRST[7:0] = 00h: Reset WDT
- ◆ Write MRRST[7:0] = FFh: Reset latch off

MRORB (Default: 00h)

(Register for OTP Programming Integrity Check. Write During EN = Low Only)

| ADDR | Data Name | D[7] | D[6] | D[5] | D[4] | D[3] | D[2] | D[1] | D[0] |
|------|-----------|------|------|------|------|------|------|-------|-------|
| 16h | MRORB | 0 | 0 | 0 | 0 | 0 | 0 | ORBEN | ORBLV |

ORBEN

Setting this bit puts the device into OTP integrity check mode.

- ◆ ORBEN = 0: Normal
- ◆ ORBEN = 1: OTP bias read mode

ORBLV

Changes the OTP readout thresholds to high and low, to verify data integrity.

- ◆ ORBLV = 0: OTP low bias read mode at ORBEN = 1
- ◆ ORBLV = 1: OTP high bias read mode at ORBEN = 1

MRODL

(Write Access During EN = Low Only)

| ADDR | Data Name | D[7] | D[6] | D[5] | D[4] | D[3] | D[2] | D[1] | D[0] |
|------|-----------|--------------------------------------|------|------|------|------|------|------|------|
| 17h | MRODL | Write 00h: Execute OTP data download | | | | | | | |

MRODL[7:0]

A write initiates an OTP data download into the main registers in standby mode. In Normal mode, OTP download can be initiated only when AWODLEN is set regardless of MRODL.

- ◆ Write MRODL[7:0] = 00h: Execute OTP data download

MRDIAG0

(Read Only)

| ADDR | Data Name | D[7] | D[6] | D[5] | D[4] | D[3] | D[2] | D[1] | D[0] |
|------|-----------|------|------|------|-------|-------|-------|------|------|
| 20h | MRDIAG0 | 0 | 0 | 0 | WDTPO | THSPO | THWPO | FSPO | OCPO |

WDTPO

Watchdog error flag.

- ◆ WDTPO = 0: Normal
- ◆ WDTPO = 1: Detect WDT error

THSPO

Over temperature shutoff flag.

- ◆ THSPO = 0: Normal
- ◆ THSPO = 1: Detect thermal shut down error

THWPO

Thermal warning flag.

- ◆ THWPO = 0: Normal
- ◆ THWPO = 1: Detect thermal warning error

FSPO

FET short circuit detection flag.

- ◆ FSPO = 0: Normal
- ◆ FSPO = 1: Detect FET short error

OCPO

Over-current error flag.

- ◆ OCPO = 0: Normal
- ◆ OCPO = 1: Detect over-current error

MRDIAG1

(Read Only)

| ADDR | Data Name | D[7] | D[6] | D[5] | D[4] | D[3] | D[2] | D[1] | D[0] |
|------|-----------|------|------|------|--------|--------|--------|--------|--------|
| 21h | MRDIAG1 | 0 | 0 | 0 | VCUVPO | VGUVPO | VDOVPO | VSOVPO | VSUVPO |

VCUVPO

VCC under-voltage flag.

- ◆ VCUVPO = 0: Normal
- ◆ VCUVPO = 1: Detect VCC under voltage error

VGUVPO

VG under-voltage flag.

- ◆ VGUVPO = 0: Normal
- ◆ VGUVPO = 1: Detect VG under voltage error

VDOVPO

VDH over-voltage flag.

- ◆ VDOVPO = 0: Normal
- ◆ VDOVPO = 1: Detect VDH over voltage error

VSOVPO

VS over-voltage flag.

- ◆ VSOVPO = 0: Normal
- ◆ VSOVPO = 1: Detect VS over voltage error

VSUVPO

VS under-voltage flag.

- ◆ VSUVPO = 0: Normal
- ◆ VSUVPO = 1: Detect VS under voltage error

MRACK

(Read Only)

| ADDR | Data Name | D[7] | D[6] | D[5] | D[4] | D[3] | D[2] | D[1] | D[0] |
|------|-----------|------|------|------|------|------|------|------|------|
| 22h | MRACK | 0 | 1 | 0 | 1 | 0 | 1 | 0 | 1 |

MRACK[7:0]

For SPI data verification. A read must result in 55h.

- ◆ MRACK[7:0] read data is fixed 55h

ORCONF0 ~ 3 (Default: 00h)

(OTP Backup for Critical System Registers. Programmable During EN = L Only)

| ADDR | Data Name | D[7] | D[6] | D[5] | D[4] | D[3] | D[2] | D[1] | D[0] |
|------|-----------|--------------|------|-------------|--------|-------------|---------|-------------|--------|
| 40h | ORCONF0 | ORCONF0[7:6] | | THTSEL | DFCSEL | DIAGLTO | DIAGPOL | VGUSEL | VCVSEL |
| 41h | ORCONF1 | ORCONF1[7:5] | | | WDTPS | THSPS | THWPS | VGUVPS[1:0] | |
| 42h | ORCONF2 | ORCONF2[7:6] | | VDOVPS[1:0] | | VSOVPS[1:0] | | VSUVPS[1:0] | |
| 43h | ORCONF3 | ORCONF3[7:1] | | | | | | | OSAENB |

ORCONF0 ~ 3

- ◆ ORCONF0 ~ 3 data is transferred to MRCONF0 ~ 3 at OTP data download
- ◆ ORCONF0[7:6], ORCONF1[7:5], ORCONF2[7:6], ORCONF3[7:1] data is not transferred to MRCONF

MECHANICAL CASE OUTLINE

PACKAGE DIMENSIONS

ON Semiconductor®

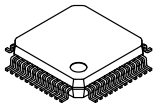

SPQFP48 7x7 / SQFP48K

CASE 131AN

ISSUE A

DATE 08 NOV 2013

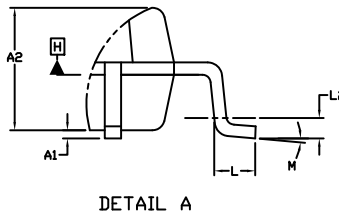
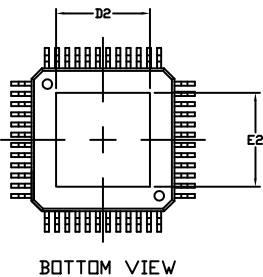
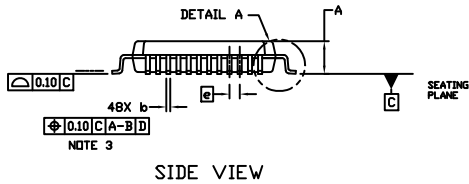
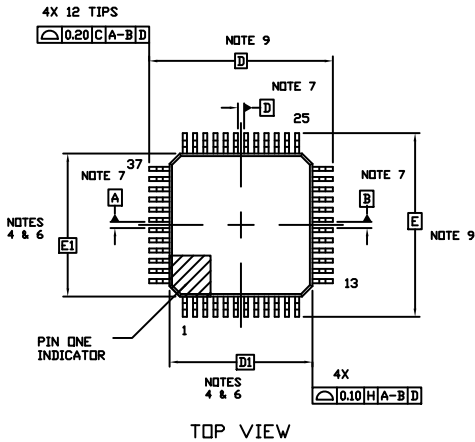

- NOTES:
1. DIMENSIONING AND TOLERANCING PER ASME Y14.5M, 1994.
 2. CONTROLLING DIMENSION: MILLIMETERS
 3. DIMENSION b DOES NOT INCLUDE DAMBAR PROTRUSION. DAMBAR PROTRUSION SHALL BE 0.08 MAX. AT MMC. DAMBAR CANNOT BE LOCATED ON THE LOWER RADIUS OF THE FOOT. MINIMUM SPACE BETWEEN PROTRUSION AND ADJACENT LEAD IS 0.07.
 4. DIMENSIONS D1 AND E1 DO NOT INCLUDE MOLD FLASH, PROTRUSIONS, OR GATE BURRS. MOLD FLASH, PROTRUSIONS, OR GATE BURRS SHALL NOT EXCEED 0.25 PER SIDE. DIMENSIONS D1 AND E1 ARE MAXIMUM PLASTIC BODY SIZE INCLUDING MOLD MISMATCH.
 5. THE TOP PACKAGE BODY SIZE MAY BE SMALLER THAN THE BOTTOM PACKAGE SIZE BY AS MUCH AS 0.15.
 6. DATUMS A-B AND D ARE DETERMINED AT DATUM PLANE H.
 7. A1 IS DEFINED AS THE VERTICAL DISTANCE FROM THE SEATING PLANE TO THE LOWEST POINT ON THE PACKAGE BODY.
 8. DIMENSIONS D AND E TO BE DETERMINED AT DATUM PLANE C.

| DIM | MILLIMETERS | |
|-----|-------------|------|
| | MIN. | MAX. |
| A | --- | 1.70 |
| A1 | 0.00 | 0.15 |
| A2 | 1.50 | REF |
| b | 0.15 | 0.26 |
| D | 9.00 | BSC |
| D1 | 7.00 | BSC |
| D2 | 4.60 | REF |
| E | 9.00 | BSC |
| E1 | 7.00 | BSC |
| E2 | 4.60 | REF |
| e | 0.50 | BSC |
| L | 0.30 | 0.70 |
| L2 | 0.25 | BSC |
| M | 0° | 10° |

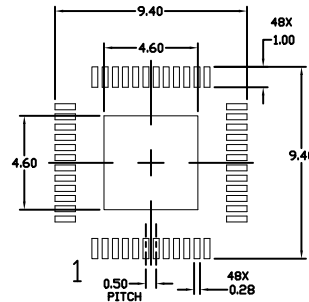

RECOMMENDED MOUNTING FOOTPRINT

| | | |
|------------------|---------------------------|--|
| DOCUMENT NUMBER: | 98AON78439F | Electronic versions are uncontrolled except when accessed directly from the Document Repository. Printed versions are uncontrolled except when stamped "CONTROLLED COPY" in red. |
| STATUS: | ON SEMICONDUCTOR STANDARD | |
| NEW STANDARD: | | |
| DESCRIPTION: | SPQFP48 7X7 / SQFP48K | PAGE 1 OF 2 |

ON Semiconductor and  are trademarks of Semiconductor Components Industries, LLC dba ON Semiconductor or its subsidiaries in the United States and/or other countries. ON Semiconductor owns the rights to a number of patents, trademarks, copyrights, trade secrets, and other intellectual property. A listing of ON Semiconductor's product/patent coverage may be accessed at www.onsemi.com/site/pdf/Patent-Marking.pdf. ON Semiconductor reserves the right to make changes without further notice to any products herein. ON Semiconductor makes no warranty, representation or guarantee regarding the suitability of its products for any particular purpose, nor does ON Semiconductor assume any liability arising out of the application or use of any product or circuit, and specifically disclaims any and all liability, including without limitation special, consequential or incidental damages. Buyer is responsible for its products and applications using ON Semiconductor products, including compliance with all laws, regulations and safety requirements or standards, regardless of any support or applications information provided by ON Semiconductor. "Typical" parameters which may be provided in ON Semiconductor data sheets and/or specifications can and do vary in different applications and actual performance may vary over time. All operating parameters, including "Typicals" must be validated for each customer application by customer's technical experts. ON Semiconductor does not convey any license under its patent rights nor the rights of others. ON Semiconductor products are not designed, intended, or authorized for use as a critical component in life support systems or any FDA Class 3 medical devices or medical devices with a same or similar classification in a foreign jurisdiction or any devices intended for implantation in the human body. Should Buyer purchase or use ON Semiconductor products for any such unintended or unauthorized application, Buyer shall indemnify and hold ON Semiconductor and its officers, employees, subsidiaries, affiliates, and distributors harmless against all claims, costs, damages, and expenses, and reasonable attorney fees arising out of, directly or indirectly, any claim of personal injury or death associated with such unintended or unauthorized use, even if such claim alleges that ON Semiconductor was negligent regarding the design or manufacture of the part. ON Semiconductor is an Equal Opportunity/Affirmative Action Employer. This literature is subject to all applicable copyright laws and is not for resale in any manner.

PUBLICATION ORDERING INFORMATION

LITERATURE FULFILLMENT:

Literature Distribution Center for ON Semiconductor
19521 E. 32nd Pkwy, Aurora, Colorado 80011 USA
Phone: 303-675-2175 or 800-344-3860 Toll Free USA/Canada
Fax: 303-675-2176 or 800-344-3867 Toll Free USA/Canada
Email: orderlit@onsemi.com

N. American Technical Support: 800-282-9855 Toll Free
USA/Canada
Europe, Middle East and Africa Technical Support:
Phone: 421 33 790 2910

ON Semiconductor Website: www.onsemi.com

Order Literature: <http://www.onsemi.com/orderlit>

For additional information, please contact your local
Sales Representative